



## RHM100

Coriolis Mass Flow Sensor for High Flow Terminal and Transfer Applications

### Features

- Standard pressure ratings up to 237 bar (3437 psi)
- Temperature ratings from -196 to 210°C (-320 to 410°F)
- Mass flow uncertainty down to 0.15%
- Density uncertainty down to 0.0025 kg/l
- Repeatability down to 0.05%
- Typical measuring ranges between 12000 and 300 kg/min
- Accurately measure low flow rates down to 200 kg/min
- Unique robust torsion driven oscillation system
- Rheonik **AnyPipeFit Commitment** brings you the possibility to get any custom process connection type and size for savings on installation costs. Compact design with minimal footprint
- Approved for use in hazardous areas
- Stainless steel case

### Applications

- Terminal Transfer
- Viscous Fluids
- Barge, Ship, Rail Car and Truck Filling

### Rheonik Sensor Benefits

- Torsion oscillator design assures a stable and drift free measurement with excellent signal to noise ratios
- Resilient to external noise and vibration
- Insensitive to pipe pressure changes
- Robust tube wall thickness provides increased operational safety in abrasive applications
- Corrosion resistant
- Long sensor life guaranteed due to low mechanical stresses in the meter mechanism
- No moving parts to wear or fail



MJ Systems, LLC  
Authorized Rheonik Representatives  
TX - Off (281) 842-7600  
LA - Off (225) 726-7114  
www.mjsusa.com • sales@mjsusa.com

## General Specification Overview

<b>Nominal Flow (<math>Q_{nom}</math>)*</b>	12000 kg/min (26455 lb/min)
<b>Minimum Flow (<math>Q_{min}</math>)*</b>	300 kg/min (661 lb/min)
<b>Operating Temperature</b>	Fluid from -196°C to 150°C (-320°F to 302°F), design up to 210°C (410°F) Ambient from -50°C to 80°C (-58°F to 176°F), optional up to 210°C (410°F)
<b>Pressure Ratings</b>	Up to 237 bar / 3437 psi - dependent upon material
<b>Electrical Connection</b>	Cable entry M25 x 1.5 (standard), M20 x 1.5, ½" NPT, ¾" NPT (optional) Max. cable length to remote RHE transmitter 30m / 98ft
<b>Sensor Enclosure Materials</b>	Stainless steel (standard), 316 stainless steel (optional) Epoxy coated aluminum terminal box (standard), SS 316 terminal box (optional)
<b>Enclosure Type</b>	Protection class IP65 (standard); IP 66 / NEMA 4X (optional)
<b>Wetted Materials</b>	1.4571 (316Ti), 2.4602 (Alloy C22), 1.4410 (SuperDuplex) Additional/customer specific materials available upon request
<b>Process Connections</b>	Nearly any - <b>the RHEONIK AnyPipeFit Commitment</b> . Consult factory for types/sizes not listed in this data sheet
<b>Pressure Rating Compliance</b>	Europe – PED: Module B3.2+C2
<b>Certifications and Approvals</b>	ATEX / IECEx Approvals for zone 0, 1, 2 (suitably rated RHE transmitter required) North American Approvals for Class I, Div. 1, Groups ABCD (suitably rated RHE transmitter required) American Bureau of Shipping (ABS) Type Approval for use on marine vessels
<b>Documentation, Testing and Inspection</b>	All sensors are hydro tested, calibrated and supplied with a traceable calibration certificate. Customized calibration and testing services available
<b>Project Documentation and QA, Services</b>	Rheonik offers a full set of services for large and complex engineering projects. Typical services offered are, but not limited to: <ul style="list-style-type: none"> <li>• Certificates of origin and conformity, mill certificates</li> <li>• Data books including WPAR, WQS, NDT, test &amp; quality plans, functional testing, calibration procedures, customized packing, factory acceptance etc.</li> <li>• Start up and commissioning services on/offshore</li> </ul>
<b>Options</b>	Enclosure heating for high temperature applications Cleaning for oxygen service Full service painting to project specifications – consult factory

\* At  $Q_{nom}$  pressure drop will be approximately 1 bar (14 psi) for H<sub>2</sub>O. Sensors can be operated at higher flow rates but pressure drop will be higher. Maximum recommended velocity (liquid) through the sensor is 15 m/s. Beyond this point, cavitation may occur.  $Q_{min}$  is the recommended lowest flow rate. Sensors will measure flow rates lower than  $Q_{min}$ , but uncertainty may increase beyond 0.5% of rate.

These flow rate and pressure drop statements relate to standard pressure tube sensor versions. Models with higher pressure ratings have increased wall thickness and will have higher pressure drops.

## Measurement Performance

### Standard Calibration

A	<b>0.5% Uncertainty</b> ±0.5% uncertainty between $Q_{nom}$ and $Q_{min}$
B	<b>0.2% Uncertainty</b> ±0.2% uncertainty between $Q_{nom}$ and $Q_{0.2}$

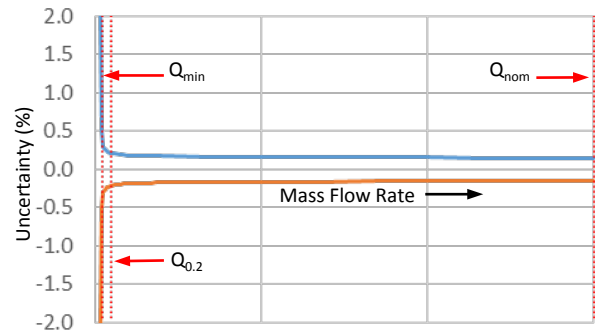

### Goldline Calibration

G	<b>0.15% Uncertainty</b> ±0.15% uncertainty between $Q_G$ and $(Q_G/5)$
---	--

Only for sensors with standard temperature and pressure range  
Customized calibration services are available – consult factory

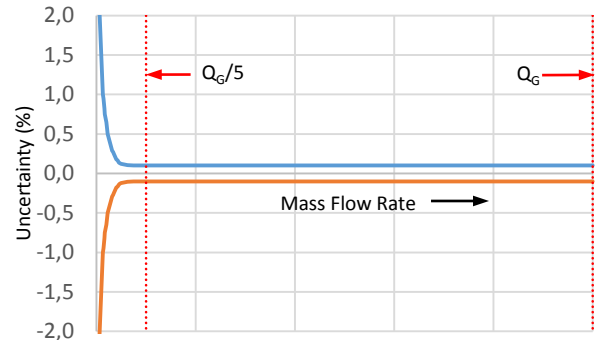

### Low Flow Calibration

2	<b>Low Flow Optimized Calibration</b> ±0.2% uncertainty between $Q_{nom}$ and $Q_{0.2}$ ±0.5% uncertainty between $Q_{0.2}$ and $Q_{min}$ ±0.7% uncertainty between $Q_{min}$ and $Q_{low}$
---	--

Only for sensors with standard temperature and pressure range

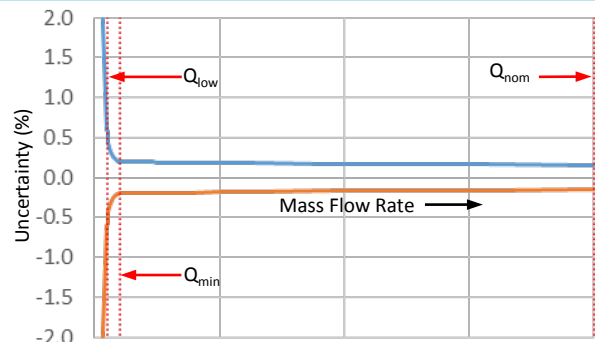

$Q_{nom}$	12000 kg/min (26455 lb/min)
$Q_{min}$	300 kg/min (661 lb/min)
$Q_G$	9000 kg/min (19842 lb/min)
$Q_{0.2}$	800 kg/min (1764 lb/min)
$Q_{low}$	200 kg/min (441 lb/min)

Select the calibration option (A,B,G,2) required and include in the overall part number

### Flow Measurement Repeatability

Standard ± 0.1% of rate  
Goldline ± 0.05% of rate

### Temperature Performance

Better than ±1°C

### Density Calibration

N*	No Live Density Calibration
S	Standard +/- 0.005 kg/liter uncertainty between 500 and 1400 kg/m <sup>3</sup>
D	Enhanced +/- 0.0025 kg/liter uncertainty between 500 and 1400 kg/m <sup>3</sup>

For live volumetric flow, S or D calibration must be included in the part number and the sensor must be operated by an RHE with live density capability.

\* Even with No Live Density Calibration, volumetric flow can still be calculated with an inferred density value based upon a manually entered norm density value and its temperature gradient.

### Calibration Reference Conditions

Performance statements relate to the following conditions:

- Water (for mass flow accuracy)
- Temperature: 18 to 24°C (66 to 76°F)
- Pressure at 1 to 3 barg (15 to 45 psig)
- RHM with standard temperature, material and pressure range

## Measurement Tube Pressure Ratings

The maximum pressure ( $P_{max}$ ) of a sensor is determined by its lowest rated part. The lowest rated part can be either the measurement tube ( $P_{max}$  indicated below) or the process connection (for  $P_{max}$  see published standards or manufacturer information).

Pressure Code	Material Code	Material	Pmax				
			bar	psi	@	°C	°F
P0 (std.)	M1 (std.)	1.4571 (316Ti) UNS S31635	73	1059	@	50	122
			66	957	@	120	248
			57	827	@	210	410
PA	M1 (std.)	1.4571 (316Ti) UNS S31635	99	1436	@	50	122
			88	1276	@	120	248
			76	1102	@	210	410
P1	M3	2.4602 (Alloy C22) UNS N06022	113	1639	@	50	122
			100	1450	@	120	248
			85	1233	@	210	410
PA	10*	1.4410 (Super Duplex) UNS S32750	237	3437	@	50	122
			208	3017	@	120	248
			188	2727	@	210	410
PA	62*	1.4462 (Duplex) UNS S31803	189	2741	@	50	122
			166	2408	@	120	248
			145	2103	@	210	410

\*Only with N1, NA, E2 temperature range. Super Duplex minimum temperature is -40°C

## Other Materials and Pressure Ratings

Higher pressure rated measurement tubes in the materials above may be possible. Other wetted materials are also possible for chemical compatibility, lower pressure drop, abrasion allowance and other application specific requirements.

Contact factory with specification for assessment and availability.

## Mechanical Construction

### Seal-less design

PFO: parallel/dual path

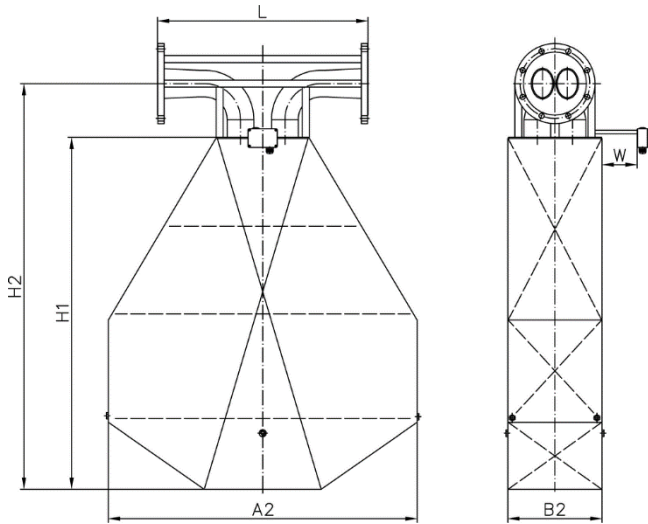

Process Connection	Dim. L	Dim. H2	Order Code
	mm / in	mm / in	
ANSI 8" 150#RF Flange	900 / 35.43	1735 / 68.31	A1
ANSI 8" 300#RF Flange	900 / 35.43	1735 / 68.31	A2
ANSI 8" 600#RF Flange	900 / 35.43	1735 / 68.31	A3
DIN DN200 PN16 Flange	900 / 35.43	1735 / 68.31	D1
DIN DN200 PN40 Flange	900 / 35.43	1735 / 68.31	D2

1. A3 flange selection will reduce maximum measurement tube pressure rating by a factor of 0.75

Dimensions	mm	in
A2	1320	51.97
B2	403	15.87
H1	1505	59.25
W	150	5.91

**Standard blue terminal box in Aluminum, size = 125 x 80 x 57 mm (4.92 x 3.15 x 2.24 in)**

- optionally available with integral RHE45 transmitter

Optional SS 316 box, size = 100 x 100 x 61 mm (3.94 x 3.94 x 2.40 in)

- only for remote transmitter

*NOTE: Junction boxes are supplied with M25 x 1.5 cable entries as standard. M20 x 1.5, ½" NPT or ¾" NPT cable entries are optionally available and must be ordered separately.*

All dimensions are for standard products. For customization of face to face length and/or process connection types other than the ones listed on this page, please consult factory. Note that larger diameter flange process connections are always possible.

## RHM100 Part Number Code

### Temperature Range

- N1 -20 to +120°C (-4 to +248°F) (std.)
- NA -50 to +120°C (-58 to +248°F)
- E2 -50 to +210°C (-58 to +410°F) - max. operating temperature 150°C
- E3 -196 to +50°C (-320 to +122°F)

### Pressure Code for Pmax of Measuring Loops (see pressure ratings page)

- P0 pmax depends upon material
- P1 pmax depends upon material
- PA pmax depends upon material

### Material of Wetted Parts

- M1 1.4571 (316Ti) (std.)
- M3 2.4602 (Alloy C22)
- XX Other materials, e.g. (Super)Duplex are available upon request

### Process Connection

See mechanical construction pages for available connections and codes

### Terminal Box Selection

- JM Coated aluminum TB, M25 cable entry (options available)
- SM SS 316 TB, M25 cable entry (options available)
- TM No TB. 2m fixed / integral PTFE cable to RHE
- J5 Coated aluminum TB for integral RHE45, one or two M12 sockets

### Options Codes

- NN No options
- See options listing for specific codes

### Hazardous Area Certifications

- NN Without Ex Approval
- A0 ATEX/IEC Approval Zone 0: Ex II 1G Ex ia IIC T1-T6 Ga
- A1 ATEX/IEC Approval Zone 1: Ex II 2G Ex ia IIC T1-T6 Gb
- C0 CSA Approval USA-Canada Class I, Div. 1, Groups ABCD

### Pressure Design Compliance

- NN No specific design compliance required
- BC PED [Europe] module B3.2+C2
- CA CRN [Canada] - Alberta province
- CR CRN [Canada] - all other provinces

### Mass Flow Calibration Selection

See performance page for code options

### Density Calibration Selection

See performance page for code options

### Additional Manufacturing Instructions

- N No manufacturing instructions
- O Oil/grease free cleaning
- S Marine packing



## Options and Accessories

RHM80L Part Number Option Codes	
H1	Hot oil/steam heating matrix for housing, DN25 PN40
H2	Hot oil/steam heating matrix for housing, 1" ANSI 150 RF
H3	Hot oil/steam heating matrix for housing, 1" ANSI 300 RF
P2	Housing purge connections - ½" NPT (2 pcs)
SB	Housing in 316 stainless steel
DY	Dye penetrant inspection
XR	X-ray test

NOTE: when specifying a sensor with multiple part code options (i.e. DY and XR), separate each code with a comma in the part string (i.e. ...DY,XR...)

Cable Entry Options (order separately)	
ORHM-E1	½" NPT Terminal Box Cable Entry
ORHM-E2	M20 x 1.5 Terminal Box Cable Entry
ORHM-E3	¾" NPT Terminal Box Cable Entry

Standard cable entry on terminal box is M25 x 1.5

## Transmitter Range



Any Rheonik Mass Flow Transmitter model can be combined with any Rheonik Mass Flow Sensor to provide an overall mass flow measurement system to suit any requirement. Rheonik Coriolis transmitters are available in versions specifically designed for process, industrial and OEM applications. Together they offer a tremendous range of options for system designers and end users alike.

See separate data sheet for the features of each transmitter style

## About Rheonik

Rheonik has a single purpose: to design and manufacture the very best Coriolis meters available. Our research and engineering resources are dedicated to finding new and better ways to provide cost effective accurate mass flow solutions. Our manufacturing group care for each and every meter we produce from raw materials all the way to shipping and our service and support group are available to help you specify, integrate, start-up and maintain each and every Rheonik meter you have in service. Whether you own just one meter or have hundreds, you will never be just another customer to us. You are our valued business partner.

Need a specific configuration for your plant - don't compromise with a "standard" product from elsewhere that will add extra cost to your installation. If we can't configure it from our extensive product range, our exclusive **AnyPipeFit Commitment** can have your flow sensor customized with any size or type process connection you need.

No matter what control system you use as the backbone in your enterprise, with our **AnyInterface Commitment**, you can be sure that connection and communication will not be a problem. Alongside a wide variety of discrete analog or digital signal connections, we can also provide just about any network/bus interface available (for example: HART, ProfibusDP, ProfiNet, EtherCAT, PowerLink, EtherNet/IP, CAN, ....) with our RHE4x family of transmitters. Rheonik RHE4X transmitters can connect to your system – no headache and no conversion needed.



**MJ Systems, LLC**  
**Authorized Rheonik Representatives**  
TX - Off (281) 842-7600  
LA - Off (225) 726-7114  
www.mjsusa.com • sales@mjsusa.com