



MJ Systems, LLC
Authorized Rheonik Representatives
TX - Off (281) 842-7600
LA - Off (225) 726-7114
www.mjsusa.com • sales@mjsusa.com

RHM30L

Coriolis Mass Flow Meter for Plant and Loading Applications

Features

- Standard pressure ratings up to 798 bar (11574 psi)
- Temperature ratings from -196 to 350°C (-320 to 662°F)
- Mass flow uncertainty down to 0.15%
- Density uncertainty down to 0.5%
- Repeatability better than 0.05%
- Typical measuring ranges between 750 and 7.5 kg/min
- Accurately measure low flow rates down to 5 kg/min
- Unique robust torsion driven oscillation system
- Rheonik **AnyPipeFit Commitment** brings you the possibility to get any custom process connection type and size for savings on installation costs. Compact design with minimal footprint
- Minimum pipe footprint versions available
- Approved for use in hazardous areas
- Stainless steel case
- Removable connection manifold version available for easy and efficient maintenance

Applications

- General Flow Control
- Plant Balance
- Additive Dosing
- High Temperature Fluids
- Viscous Fluids
- Mixing, Blending, Batching
- Package and Container Filling

Rheonik Sensor Benefits

- Torsion oscillator design assures a stable and drift free measurement with excellent signal to noise ratios
- Resilient to external noise and vibration
- Insensitive to pipe pressure changes
- Robust tube wall thickness provides increased operational safety in abrasive applications
- Corrosion resistant
- Long sensor life guaranteed due to low mechanical stresses in the meter mechanism
- No moving parts to wear or fail

General Specification Overview

Nominal Flow (Q_{nom})*	750 kg/min (1653 lb/min)
Minimum Flow (Q_{min})*	15 kg/min (33.1 lb/min)
Serial Tube/ Single Path	Flow rates Q_{nom} and Q_{min} will be 50% of the above listed parallel/dual tube version
Operating Temperature	Temperature range options cover applications from -196°C to 350°C (-320°F to 662°F)
Pressure Ratings	Up to 798 bar / 11574 psi - dependent upon material
Electrical Connection	Cable entry M25 x 1.5 (standard), M20 x 1.5, ½" NPT, ¾" NPT (optional) Max. cable length to remote RHE transmitter 30m / 98ft
Sensor Enclosure Materials	Stainless steel (standard), 316 stainless steel (optional) Epoxy coated aluminum terminal box (standard), 316 stainless steel terminal box (optional)
Enclosure Type	Protection class IP65 (standard); IP 66 / NEMA 4X (optional)
Wetted Materials	1.4571 (316Ti), 2.4602 (Alloy C22), Tantalum, 1.4410 (SuperDuplex) Seal material (manifold construction): PTFE Additional/customer specific materials available upon request
Process Connections	Nearly any - the RHEONIK AnyPipeFit Commitment . Consult factory for types/sizes not listed in this data sheet
Pressure Rating Compliance	Europe – PED: Sound Engineering Practice (SEP), Module A2, Module B3.2+C2
Certifications and Approvals	ATEX / IECEx Approvals for zone 0, 1, 2 (suitably rated RHE transmitter required) North American Approvals for Class I, Div. 1, Groups ABCD (suitably rated RHE transmitter required) American Bureau of Shipping (ABS) Product Type Approval for use on marine vessels
Documentation, Testing and Inspection	All sensors are hydro tested, calibrated and supplied with a traceable calibration certificate. Customized calibration and testing services available
Project Documentation and QA, Services	Rheonik offers a full set of services for large and complex engineering projects. Typical services offered are, but not limited to: <ul style="list-style-type: none"> • Certificates of origin and conformity, mill certificates • Data books including WPAR, WQS, NDT, test & quality plans, functional testing, calibration procedures, customized packing, factory acceptance etc. • Start up and commissioning services on/offshore
Options	Enclosure heating for high temperature applications Cleaning for oxygen service Full service painting to project specifications – consult factory

* At Q_{nom} pressure drop across a parallel tube sensor will be approximately 1 bar (15 psi) for H₂O. Sensors can be operated at higher flow rates but pressure drop will be higher. Maximum recommended velocity (liquid) through the sensor is 15 m/s. Beyond this point, cavitation may occur. Q_{min} is the recommended lowest flow rate. Sensors will measure flow rates lower than Q_{min} , but uncertainty will increase beyond 0.5% of rate.

The flow rate specifications above relate to standard pressure parallel tube sensor versions. Models with higher pressure ratings have increased wall thickness and will have higher pressure drops/lower Q_{nom} values.

Measurement Performance

Standard Calibration

A	0.5% Uncertainty ±0.5% uncertainty between Q_{nom} and Q_{min}
B	0.2% Uncertainty ±0.2% uncertainty between Q_{nom} and $Q_{0.2}$

Higher pressure units may have lower Q_{nom} values due to reduced tube ID

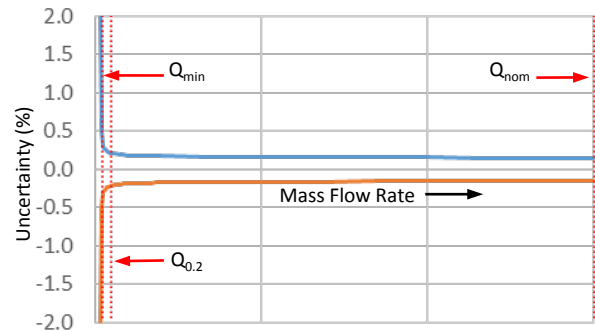

Goldline Calibration

G	0.15% Uncertainty ±0.15% uncertainty between Q_G and $(Q_G/10)$
---	---

Only for sensors with standard temperature and pressure range
Customized calibration services are available – consult factory

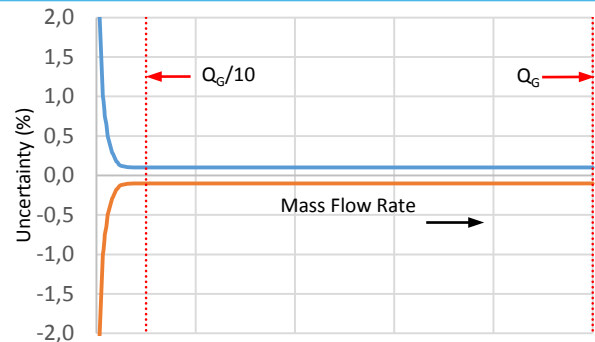

Low Flow Calibration

2	Low Flow Optimized Calibration ±0.2% uncertainty between Q_{min} and $(Q_{min} * 20)$ and ±0.6% uncertainty between Q_{min} and Q_{low}
---	---

Only for sensors with standard temperature and pressure range

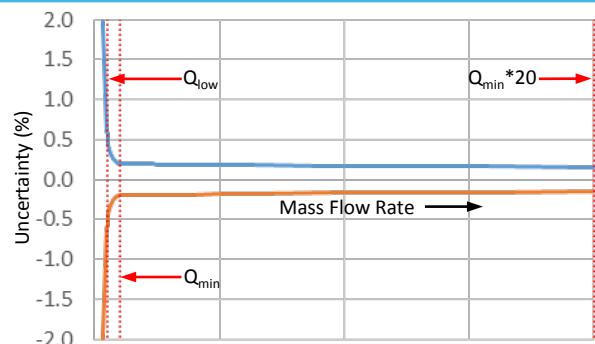

Q_{nom}	750 kg/min (1653 lb/min)
Q_{min}	15 kg/min (33.1 lb/min)
Q_G	600 kg/min (1323 lb/min)
$Q_{0.2}$	35 kg/min (77.2 lb/min)
Q_{low}	10 kg/min (22 lb/min)

Select the calibration option (A,B,G,2) required and include in the overall part number.
For Serial Tube versions, the Q values above are halved

Flow Measurement Repeatability

Standard ± 0.1% of rate
Goldline ± 0.05% of rate

Temperature Performance

Better than ±1°C

Density Calibration

N*	No Live Density Calibration
S	Standard +/- 0.005 kg/liter uncertainty between 500 and 1400 kg/m3
D	Enhanced +/- 0.0025 kg/liter uncertainty between 500 and 1400 kg/m3

For live volumetric flow, S or D calibration must be included in the part number and the sensor must be operated by an RHE with live density capability.

* Even with No Live Density Calibration, volumetric flow can still be calculated with an inferred density value based upon a manually entered norm density value and its temperature gradient.

Calibration Reference Conditions

Performance statements relate to the following conditions:

- Water (for mass flow accuracy)
- Temperature: 18 to 24°C (66 to 76°F)
- Pressure at 1 to 3 barg (15 to 45 psig)
- RHM with standard temperature, material and pressure range

Measurement Tube Pressure Ratings

The maximum pressure (P_{max}) of a sensor is determined by its lowest rated part. The lowest rated part can be either the measurement tube (P_{max} indicated below), the construction type (P_{max} indicated in the Part Number Code section) or the process connection (for P_{max} see published standards or manufacturer information).

Pressure Code	Material Code	Material	Pmax					
			bar	psi	@	°C	°F	
P1 (std.)	M1 (std.)	1.4571 (316Ti) UNS S31635	137	1987	@	50	122	
			123	1784	@	120	248	
			106	1537	@	210	410	
			89	1291	@	350	662	
	M3	2.4602 (Alloy C22) UNS N06022	271	3931	@	50	122	
			239	3466	@	120	248	
			204	2959	@	210	410	
			170	2466	@	350	662	
	M4*	Tantalum UNS R05200	44	638	@	50	122	
			39	565	@	120	248	
			36	522	@	210	410	
	P2	M1	1.4571 (316Ti) UNS S31635	334	4844	@	50	122
299				4337	@	120	248	
258				3742	@	210	410	
217				3147	@	350	662	
10**		1.4410 (Super Duplex) UNS S32750	574	8325	@	50	122	
			503	7295	@	120	248	
			455	6599	@	210	410	
62**		1.4462 (Duplex) UNS S31803	458	6643	@	50	122	
			401	5816	@	120	248	
			351	5091	@	210	410	
P3		M1	1.4571 (316Ti) UNS S31635	490	7107	@	50	122
				438	6353	@	120	248
	378			5482	@	210	410	
	319			4627	@	350	662	
	10**	1.4410 (Super Duplex) UNS S32750	798	11574	@	50	122	
			700	10153	@	120	248	
			633	9181	@	210	410	
	62**	1.4462 (Duplex) UNS S31803	637	9239	@	50	122	
			558	8093	@	120	248	
			489	7092	@	210	410	

* Only with N1, NA, E2 temperature range (note max. operating temp. is 130°C) and PF0 construction type (max. ANSI 300/PN40)

**Only with N1, NA, E2 temperature range (note min. temp. is -40°C) and seal-less construction type

Other Materials and Pressure Ratings

Higher pressure rated measurement tubes in the materials above may be possible. Other wetted materials (e.g. Inconel, Monel, 304 stainless steel, others) are also possible for chemical compatibility, lower pressure drop, abrasion allowance and other application specific requirements.

Contact factory with specification for assessment and availability.

Mechanical Construction

Sensors are manufactured with two internal measurement tubes arranged side by side. In parallel or dual path sensors (order code Pxx), these tubes are connected in parallel and the flowing fluid is split equally between them. In serial or single path sensors (order code Sxx), the internal tubes are connected end to end, creating a single path through which all fluid flows. Manifold designs have a removable inlet/outlet manifold block and utilize PTFE seals between the manifold and sensor body. In seal-less designs, the measurement tubes are continuous between the process connections and do not have seals. Manifold designs offer shorter delivery lead times and may have a lower pressure drop than seal-less designs for the same flow rate.

Manifold design with seals

PMO: parallel/dual path

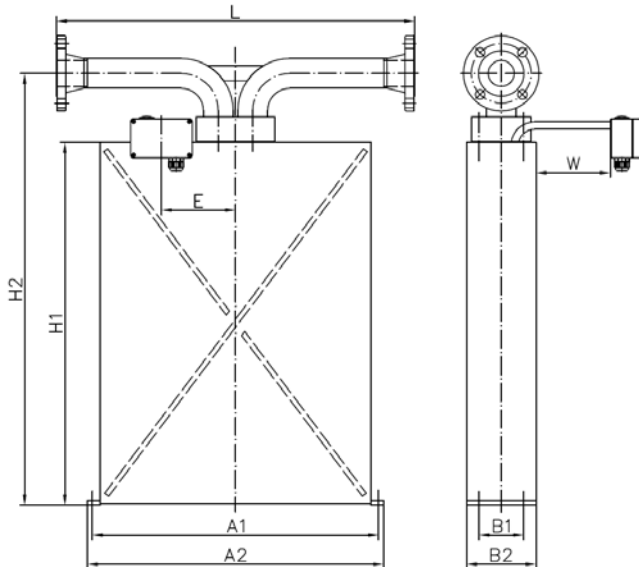

Process Connection	Dim. L	Dim. H2	Order Code
	mm / in	mm / in	
ANSI 2" 150#RF	725 / 28.54	875 / 34.45	A1
ANSI 2" 300#RF	725 / 28.54	875 / 34.45	A2
ANSI 2" 600#RF	725 / 28.54	875 / 34.45	A3
DIN DN50/PN40	725 / 28.54	875 / 34.45	D1
DIN DN50/PN100	725 / 28.54	875 / 34.45	D2
JIS RF 10k 50A (2")	725 / 28.54	875 / 34.45	J1
JIS RF 20k 50A (2")	725 / 28.54	875 / 34.45	J2

1. Manifold blocks are manufactured from 316Ti (1.4571) stainless steel

Dimensions	mm	in
	A1	580
A2	600	23.62
B1	90	3.54
B2	140	5.51
H1	735	28.94
V	50	1.97
E	150	5.91
W	150	5.91

Standard blue terminal box in Aluminum, size = 125 x 80 x 57 mm (4.92 x 3.15 x 2.24 in)

- optionally available with integral RHE45 transmitter

Optional SS 316 box, size = 100 x 100 x 61 mm (3.94 x 3.94 x 2.40 in)

- only for remote transmitter

NOTE: Junction boxes are supplied with M25 x 1.5 cable entries as standard. M20 x 1.5, ½" NPT, ¾" NPT cable entries are optionally available and must be ordered separately.

All dimensions are for standard products. For customization of face to face length and/or process connection types other than the ones listed on this page, please consult factory. Note that larger diameter flange process connections are always possible.

Mechanical Construction (continued)

Seal-less design

PFO: parallel/dual path

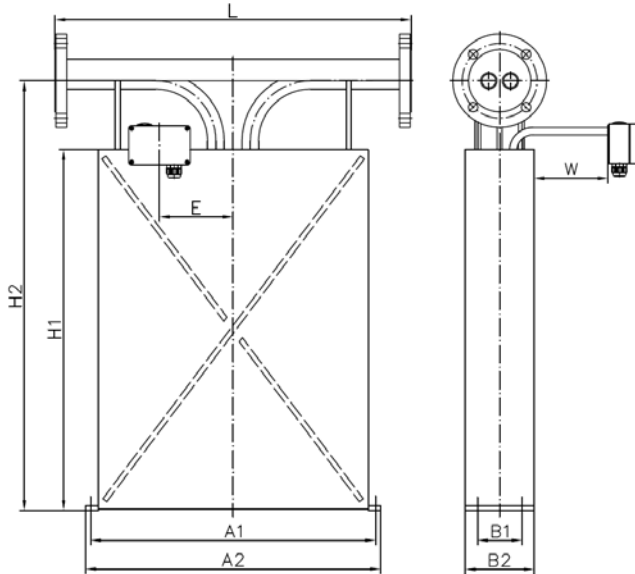

SFO: serial/single path

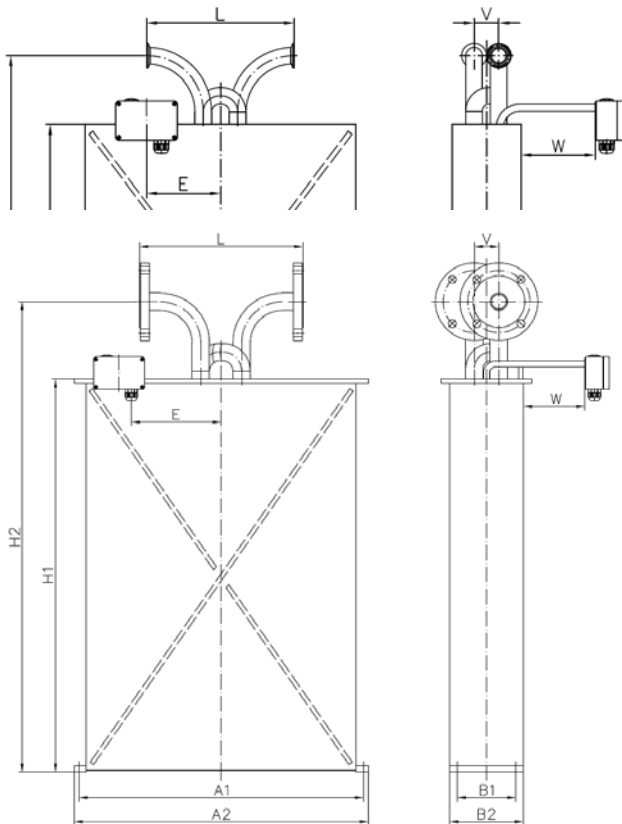

Process Connection		Dim. L	Dim. H2	Order Code
		mm / in	mm / in	
ANSI 2" 150#RF	SFO	300 / 11.81	875 / 34.45	A1
ANSI 2" 300#RF	SFO	300 / 11.81	875 / 34.45	A2
ANSI 3" 150#RF	PFO	725 / 28.54	875 / 34.45	F1
	SFO	300 / 11.81		
ANSI 3" 300#RF	PFO	725 / 28.54	875 / 34.45	F2
	SFO	300 / 11.81		
ANSI 3" 600#RF	PFO	725 / 28.54	875 / 34.45	F3
	SFO	300 / 11.81		
ANSI 3" 900#RF	PFO	725 / 28.54	875 / 34.45	A5
ANSI 3" 1500#RF	PFO	725 / 28.54	875 / 34.45	A6
ANSI 3" 600#RTJ	PFO	725 / 28.54	875 / 34.45	R1
	SFO	300 / 11.81		
ANSI 3" 900#RTJ	PFO	725 / 28.54	875 / 34.45	R2
ANSI 3" 1500#RTJ	PFO	725 / 28.54	875 / 34.45	R6
ANSI 3" 2500#RTJ	PFO	900 / 35.43	875 / 34.45	R3
DIN DN80/PN40	PFO	725 / 28.54	875 / 34.45	C1
	SFO	300 / 11.81		
DIN DN80/PN100	PFO	725 / 28.54	875 / 34.45	C2
	SFO	300 / 11.81		
DIN DN80/PN320	PFO	725 / 28.54	875 / 34.45	C4
Sanitary 1½in Triclamp, DIN 32676	SFO	300 / 11.81	875 / 34.45	S1
Sanitary NW32, DIN 11851	SFO	300 / 11.81	875 / 34.45	S2

1. For hub connectors (e.g. Destec, Galperti, Graylok, Techlok) or JIS flanges please consult factory
2. SFO meters are constructed with offset inlet/outlet ports. Consideration should be given to the offset (dimension V) when planning installation
3. Pmax for sanitary fitting S1 is 17.2 bar (250 psi) @ 120°C (248°F)
4. Pmax for sanitary fitting S2 is 40 bar (580 psi) @ 120°C (248°F)
5. Meter will be supplied with a 316 stainless steel backing flange and wetted material facing disc for some material selections (e.g. Tantalum)
6. Other dimensions on previous page

All dimensions are for standard products. For customization of face to face length and/or process connection types other than the ones listed on this page, please consult factory. Note that larger diameter flange process connections are always possible.

RHM30L Part Number Code

Temperature Range

- N1 -20 to +120°C (-4 to +248°F) (std.)
- NA -50 to +120°C (-58 to +248°F)
- E2 -50 to +210°C (-58 to +410°F) (For Tantalum sensors max. operating temp. 130°C/max design temp. +210°C)
- E3 -196 to +50°C (-320 to +122°F)
- H4 0 to +350°C (+32 to +662°F)

Pressure Code for Pmax of Measuring Loops (see pressure ratings page)

See pressure ratings page for ratings and codes

Construction Type (pmax @ 120°C (248°F))

- PM0 Parallel manifold, pmax = 128.8 bar (1869 psi)
- PF0 Parallel path, seal-less
- SF0 Serial path, seal-less

Material of Wetted Parts

- M1 1.4571 (316Ti) (std.)
- M3 2.4602 (Alloy C22), seal-less construction types only
- M4 Tantalum, PF0 construction type only, max. ANSI 300/PN40
- XX Other materials, e.g. SuperDuplex, Monel are available upon request

Process Connection

See mechanical construction pages for available connections and codes

Terminal Box Selection

- JM Coated aluminum TB, M25 cable entry (options available)
- SM SS 316 TB, M25 cable entry (options available)
- TM No TB. 2m fixed / integral PTFE cable to RHE
- J5 Coated aluminum TB for integral RHE45, one or two M12 sockets

Options Codes

- NN No options

See options listing for specific codes

Hazardous Area Certifications

- NN Without Ex Approval
- A0 ATEX/IEC Approval Zone 0: Ex II 1G Ex ia IIC T1-T6 Ga
- A1 ATEX/IEC Approval Zone 1: Ex II 2G Ex ia IIC T1-T6 Gb
- C0 CSA Approval USA-Canada Class I, Div. 1, Groups ABCD

Pressure Design Compliance

- NN No specific design compliance required
- A2 PED to module A2 unless unstable gas
- BC PED to module B3.2+C2 if A2 does not apply
- CA CRN - Alberta Province Only
- CR CRN - All Provinces except Alberta

Mass Flow Calibration Selection

See performance page for code options

Density Calibration Selection

See performance page for code options

Additional Manufacturing Instructions

- N No manufacturing instructions
- O Oil/grease free cleaning
- S Marine packing



Options and Accessories

RHM30L Part Number Option Codes	
H1	Hot oil/steam heating matrix for housing, DN25 PN40
H2	Hot oil/steam heating matrix for housing, 1" ANSI 150 RF
H3	Hot oil/steam heating matrix for housing, 1" ANSI 300 RF
P2	Housing purge connections - ½" NPT (2 pcs)
SB	Housing in 316 stainless steel
DY	Dye penetrant inspection
XR	X-ray test – PM0 (flange) type only

NOTE: when specifying a sensor with multiple part code options (i.e. P2 and SB), separate each code with a comma in the part string (i.e. ...P2,SB...)

Cable Entry Options (order separately)	
ORHM-E1	½" NPT Terminal Box Cable Entry
ORHM-E2	M20 x 1.5 Terminal Box Cable Entry
ORHM-E3	¾" NPT Terminal Box Cable Entry

Standard cable entry on terminal box is M25 x 1.5

Transmitter Range



Any Rheonik Mass Flow Transmitter model can be combined with any Rheonik Mass Flow Sensor to provide an overall mass flow measurement system to suit any requirement. Rheonik Coriolis transmitters are available in versions specifically designed for process, industrial and OEM applications. Together they offer a tremendous range of options for system designers and end users alike.

See separate data sheet for the features of each transmitter style

About Rheonik

Rheonik has a single purpose: to design and manufacture the very best Coriolis meters available. Our research and engineering resources are dedicated to finding new and better ways to provide cost effective accurate mass flow solutions. Our manufacturing group care for each and every meter we produce from raw materials all the way to shipping and our service and support group are available to help you specify, integrate, start-up and maintain each and every Rheonik meter you have in service. Whether you own just one meter or have hundreds, you will never be just another customer to us. You are our valued business partner.

Need a specific configuration for your plant - don't compromise with a "standard" product from elsewhere that will add extra cost to your installation. If we can't configure it from our extensive product range, our exclusive **AnyPipeFit Commitment** can have your flow sensor customized with any size or type process connection you need.

No matter what control system you use as the backbone in your enterprise, with our **AnyInterface Commitment**, you can be sure that connection and communication will not be a problem. Alongside a wide variety of discrete analog or digital signal connections, we can also provide just about any network/bus interface available (for example: HART, ProfibusDP, ProfiNet, EtherCAT, PowerLink, EtherNet/IP, CAN,) with our RHE4x family of transmitters. Rheonik RHE4X transmitters can connect to your system – no headache and no conversion needed.



MJ Systems, LLC

Authorized Rheonik Representatives

TX - Off (281) 842-7600

LA - Off (225) 726-7114

www.mjsusa.com • sales@mjsusa.com