

Diaphragm Seals & Solutions

Catalogue



MJ Systems, LLC
Authorized Bliss Distributors
TX - Off (281) 842-7600
LA - Off (225) 726-7114
www.mjsusa.com • sales@mjsusa.com



WHO WE ARE

Galileo Galilei once said ‘measure what is measurable and make measurable what is not so.’ Four hundred years later, this is exactly what we do. We’re a family-owned company specialised in high quality mechanical process instrumentation. Founded back in 1957 as a production- and repair shop for thermometers, today we are a leading manufacturer of diaphragm seals, pressure gauges, temperature gauges, thermowells, valves and manifolds. We have offices and facilities in Europe, the Middle East, India, the Far East, and Americas.

A PASSION FOR EXCELLENCE

Our mission is to create the best process instruments on the market. But we believe the way we make those instruments is just as important. In everything we do, quality is leading. It’s something we never compromise on. Whether we’re talking about the raw materials we use, our production processes, the way we service our customers or simply the state of our end product: if it’s not great, it’s just not good enough.

GETTING THE JOB DONE

We operate in a field where solutions aren’t always easy. At times, they might even seem impossible. That’s where we excel. Not only do we conceive, develop and produce instruments that let you accurately monitor your processes, we also offer 24/7 assistance to keep your business running smoothly. From off-the-shelf products to custom-made innovations, we take pride in delivering the right answer to your needs – no matter how complex they are.

WORKING TOGETHER

Our passion for quality extends into our customer service. Our technical support team works with you every step of the way, making sure you optimally benefit from our products. Drawing on our vast knowledge of a wide range of industries, we’ll guide you through the instrument selection process and provide technical support throughout and after completion of the project. Backed up by our dedicated maintenance and repair service, you can always rely on our instruments to carry out the task they were designed for.

PERFORMANCE THROUGH INNOVATION

How can we make things better: it’s the one question that’s constantly on our minds. We’re always looking for ways to optimize our product efficiency, ease of installation, packaging and durability. Some of these changes are so small, you might not even notice them. But others may be significant, such as the addition of a new product to our range. Whatever their impact, our innovations are always born out of our ambition to create better products and services, so you can excel in delivering yours.

OUR STORY	3
I – GENERAL INFORMATION	7
Introduction Diaphragm Seals	8
Basic Principles of Diaphragm Seal Technology	11
Pressure	11
Temperature	14
Mounting	17
Diaphragm Seal Type Overview	22
Flush Flanged Diaphragm Seals	22
Flanged Slip On (FSO) Diaphragm Seals	23
Threaded Diaphragm Seals	23
Sanitary Diaphragm Seals	24
Special Diaphragm Seals	24
Flush Rings, Flush Flanges and Reducer Flanges	25
Diaphragm Seal Accessories	25
Diaphragm Seal Specification Overview	26
Flanged and FSO Diaphragm Seals	26
Threaded, Sanitary, and Special Diaphragm Seals	28
II – DATA SHEETS – DIAPHRAGM SEALS	29
Flanged Diaphragm Seals	
BF flush diaphragm, flanged type	30
BRF flush diaphragm, exotic wetted parts, flanged type	35
BC flush diaphragm, wafer type	38
BRC flush diaphragm, exotic wetted parts, wafer type	41
EXT extended diaphragm, flanged type	43
USF internal diaphragm, flanged type	46
USLF internal diaphragm, flanged type	48
Flanged Slip On – FSO Diaphragm Seals	
FSO-BF flush diaphragm, flanged type	50
FSO-BRF flush diaphragm, exotic wetted parts, flanged type	55
FSO-EXT extended diaphragm, flanged type	58
Threaded Diaphragm Seals	
UST internal diaphragm, threaded type	60
USLT internal diaphragm, threaded type	62
ECx internal diaphragm, threaded type	64
PS flush diaphragm, threaded type	67
Sanitary Diaphragm Seals	
SAx flush or extended diaphragm	69
ILSF in-line diaphragm, wafer type	74
Special Diaphragm Seals	
HTDS high temperature diaphragm seal	76
BHS internal or flush diaphragm, hub connector	79
SJ extended diaphragm, bolted type	81
BHP internal sensing element, high pressure	84

III – DATA SHEETS – FILL FLUIDS	85
Diaphragm Seal Fill Fluids Overview	86
BSO-02	88
BSO-03	89
BSO-06	90
BSO-18	91
BSO-20	92
BSO-21	93
BSO-22	94
BSO-25	95
BSO-36	96
BSO-40	97
BSO-41	98
BSO-42	99
BSO-45	100
BSO-46	101
BSO-48	102
IV – DATA SHEETS – ACCESSORIES	103
Flush Flange	104
Flush Ring	107
Reducer Flange	111
Support Handles	113
Heavy Duty Support Tube	113
TR – Temperature Reducer	114
TC – Temperature Compensator	114
Capillary	115
V – SOLUTIONS	117
HTDS – High Temperature Diaphragm Seal	118
LGP – Low Gauge Pressure	119
Gold Coating	120
TC – Temperature Compensator	121
DLD – Diaphragm Leak Detection	122
Heavy Duty Support Tubes	123
Raised Face Covered (BRF / BRC)	124
VI – ADDENDA	125
Flange Dimensions ASME	126
Flange Dimensions EN	131
Pressure Temperature Ratings ASME	135

INTRODUCTION

Modern chemical processing and process manufacturing procedures demand ever greater accuracy and reliability from their pressure, level and flow measuring instruments. This is important to minimise costs, and to keep production downtime and shut downs to an absolute minimum. In various situations it is necessary to isolate and therewith protect the pressure measuring instrument from the process medium in order to maintain the required accuracy and reliability objectives. This isolation or separation of the instrument and the process is typically done by means of Diaphragm Seals, to protect the vulnerable measuring instrument. This protection enhances the lifetime of the measuring instrument significantly.

Before the start of any project related to the pressure, level and flow applications one should understand the possibilities of Diaphragm Seals. Badotherm's expertise and experience are there to ensure that the right solutions are offered to meet the needs from the start and prevent any problems at a later stage. When Diaphragm Seals are needed the material characteristics, operating conditions for the instruments, and choice of mounting should be taken into account.

OPERATING PRINCIPLE

A Diaphragm Seal System consists of a measuring instrument, typically a pressure transmitter or pressure gauge, with one or two Diaphragm Seals and either a direct mount construction or with capillary lines, filled with a fill fluid. A correctly prepared and filled Diaphragm Seal System will accurately transfer process pressure on the diaphragm to the sensing element of the measuring instrument. This is based on Pascal's principle which states that a pressure exerted on a fluid is transmitted undiminished through that fluid in every direction. The figures presents a schematic overview of this operating principle:

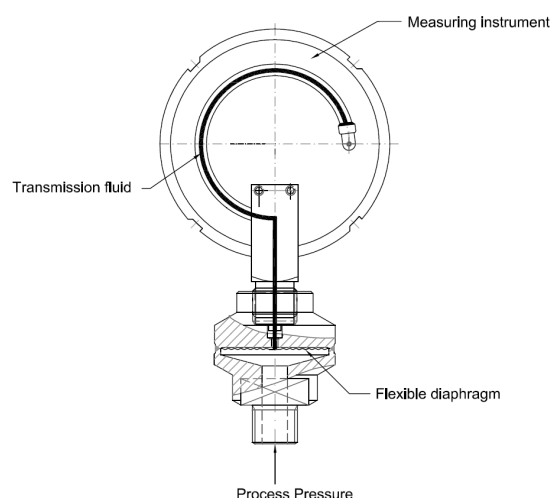

The process pressure exerts a force on the outside face of the seal, the flexible diaphragm. As the diaphragm flexes under this force it pushes inwards and attempts to compress the transmission or fill fluid behind the diaphragm. The transmission fluid is designed to withstand compression so the force is channelled proportionally and directly in to the measuring instrument to produce a resultant reading on the connected instrument.

WHEN TO USE DIAPHRAGM SEALS

Diaphragm Seals are typically used to protect the measuring instrument. There are many different situations in which a Diaphragm Seal should be typically considered:

- **Corrosive medium:** When the process medium is corrosive it would chemically attack the wetted parts of a standard pressure measuring instrument.
- **Viscous medium:** When the process medium is highly viscous or contains solid particles, either of which could result in the instrument's pressure inlet getting blocked.
- **Solidification:** When the process medium is prone to solidification, crystallization and/or polymerization over time. The medium may freeze when the temperature drops, it may set as it dries, or it may be subject to polymerisation. In these situations the pressure inlet can get blocked.

- **High/low temperatures:** When the process medium temperature is very high or very low and exceeds the temperature limits of the pressure measuring instrument resulting in damaged measurement instruments.
- **Sanitary requirements:** When the process is easily affected by the formation of bacteria on or in the process connection. The presence of bacteria in the process medium can lead to rejection of production batches. These applications where hygiene is of paramount importance are often found in the pharmaceutical, food and beverage industry.
- **Specific process connections:** When the location of the pressure measurement is not suitable for a direct mounting of a pressure measuring instrument. A diaphragm with remote mounting, by means of capillary, ensures easy visual check of the instrument.
- **Replacing 'wet legs':** As a substitution for so-called 'wet legs' for liquid level measurements in pressure retaining tanks.
- **Hydrogen permeation:** Also Diaphragm Seals are used when in the process there is a chance of presence of hydrogen ions (H+) that can permeate the diaphragm. In those cases, a diaphragm seal with gold plating offers the required protection.
- **Mounting effect:** The mounting effect on a Diaphragm Seal System is the variation in the pressure represented by the vertical fill fluid column between the Diaphragm Seal and the instrument, due to the variation of the gravity of the fill fluid as a result of ambient temperature deviation.
- **Zero shift:** The most common application of Diaphragm Seals is a level measurement. Proper ranging of a transmitter for level service requires considering the specific gravity of both the fill fluid and the process fluid, and the transmitter range.
- **Temperature effect:** Changes in volume of the Diaphragm Seal System are referred to as temperature effects. They are caused by changes in volume and density of the fluid in the system and occur when the fill fluid expands or contracts caused by fluctuations of the process and/or ambient temperatures. This change in fill volume drives a change in the internal pressure of the Diaphragm Seal System.
- **Diaphragm characteristics:** The characteristics of the diaphragm itself are important for the performance. In general, a larger diaphragm diameter allows for more flexibility and is more sensible to changes in the volume due to temperature influences. Other diaphragm characteristics as the material, the thickness of the diaphragm as well as the convolution pattern, are an important factor as they all have an effect on the performance of the Diaphragm Seal System.
- **Fill fluid characteristics:** Each fill fluid has its own characteristics, such as density, viscosity, thermal expansion, and vapour pressure. These characteristics are influenced by the systems pressure and temperature and determine the performance of the Diaphragm Seal System. The selection of the fill fluid depends on factors such as temperature, pressure, volume to be displaced (response time) and process safety. Most used fill fluids are silicone oil, glycerin, or vegetable oils. Also special inert fill fluids, such as Halocarbon® for chloride and oxygen applications and other special filling fluids for high temperatures (up to 410 °C) are used.

PERFORMANCE CONSIDERATIONS

Mounting a Diaphragm Seal to a pressure instrument changes the performance of the instrument. The Diaphragm Seal System will have additional temperature effects and response time depending on the system configuration. The performance of the entire Diaphragm Seal System needs to be evaluated when specifying a new application to ensure satisfactory performance when mounted in process.

- **System volume:** The fill volume in the Diaphragm Seal System needs to be minimized as much as possible. The more volume in the system, the higher the (potential) effect of temperature. For better performance always keep the system volume as small as possible, for instance by keeping capillaries as short as possible. Also it is advised not to use different capillary lengths at HP and LP of a DP measurement.

BASECAL

BaseCal is Badotherm's web-based Diaphragm Seal performance calculation software. BaseCal simplifies the proper selection of Diaphragm Seal transmitter combinations. Regardless the application (flow, pressure, level, etc), users can select the Diaphragm Seal System for the needs of the application. The software requests you to fill out the application parameters and will then calculate the correct calibration range. BaseCal considers the following application variables:

- Mounting style
- Differential, absolute or gauge application
- Ambient and process temperature
- Operating and design pressure
- Filling fluid volume, thermal expansion and vapour pressure characteristics
- Diaphragm seal type
- Diaphragm diameter and material
- Capillary length and inside diameter

In BaseCal the Badotherm Diaphragm Seal types can be selected together with the brand and type of transmitter required. BaseCal will calculate the total performance of the diaphragm seal/transmitter combination expressed as TPE (total probable error) and the response time of the system at several temperatures. An account can be obtained at www.Basecal.com.

INTRODUCTION

Diaphragm Seals on instruments are used to measure pressure. Pressure can be described as a force applied on a surface. There are different ways of expressing pressures. It can be expressed in kilogramforce per square centimetre (kgf/cm²), whereby kgf stands for a force and cm² for the surface the pressure is applied on. Same is valid for the commonly used Pounds per Square Inch (PSI). Pressure can also be expressed in various other units and most common are: bar, mbar, kPa and MPa, mmHG = Torr (vacuum measurement), mmH₂O, inchH₂O. The pressure that is present on a daily basis is the atmospheric pressure, which averages at 101,325 kPa.

In the industry pressure is typically used to create a chemical or physical reaction. By either raising or reducing the pressure a reaction takes place to obtain the desired result or product. This change to atmospheric pressure can be done by either heating or boiling a gas or fluid, by pumping a gas or fluid, by compressing a gas or by a chemical reaction as a result of mixing several substances. To control this process and to prevent that it runs out of control, these changes to atmospheric pressure need to be measured accurately.

ABSOLUTE-, GAUGE-, AND DIFFERENTIAL PRESSURE

Depending on what to measure, three sorts of pressures have been defined. They are differentiated by the zero reference used:

ABSOLUTE PRESSURE: is zero referenced against an absolute vacuum, so it is equal to gauge pressure minus atmospheric pressure. In order to make clear that it concerns absolute pressure an 'a' is added to the unit of measure, e.g.: mbara; PSla

GAUGE PRESSURE: is zero referenced against atmospheric pressure, so it is equal to absolute pressure plus atmospheric pressure. Negative signs are usually omitted. In order to make clear that it concerns gauge pressure 'g' is added to the unit of pressure, e.g.: mbarg; PSIg

DIFFERENTIAL PRESSURE: is the difference in pressure between two values

DEFINITIONS OF PRESSURE IN PROCESS INDUSTRY

Within the process industry different nominations of pressures are commonly used. The most relevant pressures for Diaphragm Seal Systems are the design pressure, the maximum working pressure, and the operating pressure.

MAXIMUM WORKING PRESSURE (MWP): is the highest pressure a device can withstand without bursting or failure in any way

The MWP is higher than any other pressure that can occur in process.

DESIGN PRESSURE: both the lowest and highest pressure that can occur in a given process specification

The minimum/maximum design pressure is reached when the process runs out of control and before the safety devices (e.g. pressure relief valves, rupture discs) come into service. Design pressures need to be taken into consideration during design phase to ensure mechanical integrity of the device when exposed to these design pressures. Proper functioning after exposure to the minimum/maximum design pressure is not required.

OPERATING PRESSURE:

- Minimum: the lowest pressure under which the process still runs stable
- Normal: the pressure under which the process runs optimally
- Maximum: the highest pressure under which the process still runs stable

Operating pressures need to be considered to ensure proper functioning of the device as such they are important for selecting the correct diaphragm seal design and fill fluid.

STATIC PRESSURE: the pressure at a nominated point in the process

Static pressure is commonly used to avoid ambiguity and to distinguish it from total pressure and dynamic pressure. Static pressure is identical to pressure and can be

either one of the above mentioned nominations of pressure. The static pressure is especially important in case of differential pressure measurement. E.g. pressure at high pressure (HP) side is 100,1 barg; pressure at low pressure (LP) side is 100 barg, then the differential pressure (dP) is 0,1 bar, and the value of the static pressure is 100 bar.

HYDROSTATIC PRESSURE: is the pressure exerted by a fluid column due to the force of gravity

With hydrostatic pressure measurement it is possible to measure level in vessels, tanks, reactors etc. This is one of the most common applications for Diaphragm Seals. Also the hydrostatic pressure can be used to measure changes in density.

A proper Diaphragm Seal selection is influenced by the above mentioned pressures of the process. Each diaphragm seal type has limitations according its construction or body material. For flanged connections an addendum is provided showing the maximum and minimum pressure/temperature ratings. Both flanged and threaded process connections have standard restrictions in withstanding pressure (EN1092-1, ASME B16.5, ANSI B1.20.1, ISO7005-1, ISO228-2, ISO10423, JIS B2220). The construction of the Diaphragm Seal however can also be a restrictive factor and is specified on the data sheets as the maximum working pressure of the specific Diaphragm Seal.

VACUUM

Care should be taken when specifying a Diaphragm Seal System for measuring with process pressure under vacuum.

FULL VACUUM: the absence of matter

While the Diaphragm Seals perform normally for most standard vacuum applications, as the pressure moves closer to a full vacuum acceptable reliability becomes more difficult to achieve. This is due to the fact that most fill fluids contain microscopic amounts of air or trapped gases, which tend to expand significantly as a pressure of absolute zero is approached. This expansion undermines one of the most important component factors of a seal system, that of absolutely constant fill fluid volume at any pressure. In order to overcome this

potential problem, the Badotherm filling technology allows for a complete degassing of the fill fluid, at a pressure of $< 1 \cdot 10^{-8}$ mbara in combination with the correct heating of the applied fill fluid.

Also, under vacuum process conditions, there is a potential risk that through a gasket or thread air is sucked in the system, with all possible consequences for the functioning of the Diaphragm Seal System. With Badotherm's full welded construction the measuring element has no gasket anymore to avoid any kind of leakage. Often vacuum occurs unintentionally for example during cleaning and fast cooling processes. To cover this often unknown and unaware presence of vacuum all Badotherm Diaphragm Seals are standard tested at 35 mbara even when no vacuum value is specified.

The presence of vacuum in process is a very important factor when selecting the Diaphragm Seal fill fluid and mounting the instrument. The relation between the vacuum value and the process temperature should be checked in the vapour pressure curves of the fill fluid to see if the fill fluid is suitable. When mounting the instrument for a vacuum application, the instrument should be placed below the (lowest) Diaphragm Seal to protect the instrument.

DIAPHRAGM SEAL PRESSURE SPECIFICATIONS

The size of the diaphragm defines the minimum pressure range that the Diaphragm Seal can handle. Apart from the diameter, the flexibility of the diaphragm is also related to the shape and number of convolutions, the material, and its thickness. Badotherm diaphragms have standard thickness of 75 μm . The dD dimensions mentioned are values for the active diameters of the diaphragms i.e. the outside diameter of the outer convolution. Badotherm Diaphragm Seals have a maximum static pressure effect of 0,25% of calibrated DP span on top of the standard differential pressure transmitter specifications with regard to static pressure effects. In general the total effect is $< 0,5\%$ of calibrated DP span.

The following table presents an overview of the diaphragm size and the related pressure characteristics:

MINIMUM PRESSURE RANGE OR SPAN

	DP transmitter (mbar)			GP/AP transmitter (mbar)				Pressure gauge (bar)						BDT13 (mbar)
	1m	5m	15m	Direct	1m	5m	15m	63mm		100mm		160mm		
Diaphragm size								Direct	5m	Direct	5m	Direct	5m	
17mm	-	-	-	100 bar	-	-	-	100	-	-	-	-	-	-
20mm	-	-	-	50 bar	-	-	-	100	100	-	-	-	-	-
23mm	-	-	-	4 bar	5 bar	6 bar	10 bar	6	25	-	-	-	-	-
32mm	-	-	-	2 bar	2.5 bar	3 bar	4 bar	2.5	10	25	25	100	100	-
44mm	200	400	400	1200	1500	1800	2100	1.6	6	2.5	4	4	25	-
51mm	100	200	200	800	1000	1200	1400	1	1.6	1.6	2.5	2.5	4	-
57mm	50	100	100	600	750	900	1050	0.6	1	1	1.6	1.6	2.5	-
72mm	25	50	50	200	250	300	350	0.6	0.6	0.6	0.6	0.6	0.6	-
81mm	10	20	20	80	100	120	140	0.6	0.6	0.6	0.6	0.6	0.6	100

Notes:

- Minimum pressure ranges are only related to the diaphragm sizes. The pressure range of the transmitter or pressure gauge, and the capillary diameter should be adjusted accordingly.
- DP, GP & AP transmitter sensor diaphragm should be equal or smaller than seal diaphragm size.
- DP transmitter values applicable for double sided diaphragm seals.
- Pressure gauge dimensions refer to the internal size.

Testing variables:

- AISI 316(L) diaphragm material.
- Transmitter volume is average of various transmitters brands.
- Reference temperature 20°C.
- Capillary inside diameter 2mm (1mm for pressure gauges).
- Fill fluid BSO-22.

MAXIMUM PRESSURE

	DP transmitter (mbar)	GP/AP transmitter (mbar)	Pressure gauge (bar)						BDT13 (bar)
			63mm		100mm		160mm		
Diaphragm size			Direct	5m	Direct	5m	Direct	5m	
17mm	Limited to instrument or Diaphragm Seal pressure rating	Limited to instrument or Diaphragm Seal pressure rating	700	140	-	-	-	-	-
20mm			1000	250	-	-	-	-	-
23mm			1600	400	-	-	-	-	-
32mm			1600	1400	1400	540	1000	340	-
44mm			1600	1600	1600	1600	1400	1400	-
51mm			1600	1600	1600	1600	1600	1600	-
57mm			1600	1600	1600	1600	1600	1600	-
72mm			1600	1600	1600	1600	1600	1600	-
81mm			1600	1600	1600	1600	1600	1600	25

Notes:

- Maximum pressure ranges are only related to the diaphragm sizes. The pressure range of the transmitter or pressure gauge, flange rating and the capillary diameter should be adjusted accordingly.
- Pressure gauge dimensions refer to the internal size.

Testing variables:

- AISI 316(L) diaphragm material.
- Reference temperature 20°C.
- Capillary inside diameter 1mm.
- Fill fluid BSO-22.

INTRODUCTION

Temperature expresses the average energy of motion of particles in matter. A good explanation can be made with water: when water is solid (ice) the particles (H₂O molecules) are not in motion and the temperature is thus low (cold). When fluid the H₂O molecules move faster and the temperature becomes higher. When the H₂O molecules move that fast that they release themselves from the fluid, steam is formed and the temperature is high. The motion of particles in matter is also influenced by the pressure exerted on the matter. In the example, water boils at 100°C at atmospheric pressure (101,325 kPa); at absolute vacuum it boils at 0°C. This combined effect of pressure and temperature exists for all fluids and is as such a predominant factor for the selection of the Diaphragm Seal fill fluid.

The common units of measure for temperature are: Kelvin, Celsius, and Fahrenheit. The relation between these units is presented in the table below:

	Celsius	Kelvin	Fahrenheit
Celsius	-	$K=C + 273.15$	$F=C \times 1.8 + 32$
Kelvin	$C=K-273.15$	-	$F=K \times 1.8 - 459.67$
Fahrenheit	$C=(F-32)/1.8$	$K=(F+459.67)/1.8$	-

DEFINITIONS OF TEMPERATURE IN PROCESS

INDUSTRY

Within the process industry, several temperatures are defined:

AMBIENT TEMPERATURE: is the temperature of the surroundings

When a Diaphragm Seal System is situated outdoors, the ambient temperature can become a very important factor for the functionality of the Diaphragm Seal System. Ambient temperatures can range from extremely high (>60°C e.g. in desert sun) to low (<-40°C, e.g. off-shore wind). Ambient temperatures should be specified with a minimum and maximum value, e.g. -10/+35°C would be a general specification for the Netherlands.

Similar to process pressures, process temperatures are specified with following denominations:

DESIGN TEMPERATURE: both the lowest and highest temperature that can occur in a given process specification

The design temperature is reached when the process runs out of control. Design temperatures need to be taken into consideration during design phase to ensure mechanical integrity of the device when exposed to these design temperatures. Proper functioning after this exposure is not required.

OPERATING TEMPERATURE:

- Minimum: the lowest temperature under which the process still runs stable
- Normal: the temperature under which the process runs optimally
- Maximum: the highest temperature under which the process still runs stable

Operating temperatures need to be considered to ensure proper functioning of the device and as such they are important to select the correct Diaphragm Seal design and fill fluid. The device will operate effectively within a specified operating temperature range which varies based on the device function and application context, and ranges from the minimum operating temperature to the maximum operating temperature (or peak operating temperature). Outside of this range, the device may fail. Each Diaphragm Seal has limitations according its construction or base material. For the flange connection a guide is provided, showing the maximum and minimum temperature ratings. This guide also details limitations on the flanges concerning at what pressure they can be used at specific temperatures. The maximum operating temperature is limited by the sealed system component with the lowest maximum temperature. The limiting component may be, but is not limited to, any one of the following: housing material, diaphragm material, gasket or o-ring material, or fill fluid.

TEMPERATURE EFFECTS

Changes in the volume of the Diaphragm Seal System can be caused by changes in volume and density of the fluid in the system and occur when the fill fluid expands or contracts due to fluctuations of the process and/or ambient temperatures. This change in fill volume drives

a change in the internal pressure of the Diaphragm Seal System. This is called the temperature effect.

There are 3 different influences that can be distinguished:

- **Process temperature:** the process temperature has effect on the Diaphragm Seal system and influences, in combination with the lowest process pressure, the selection of the fill fluid.
- **Ambient temperature:** Differences in ambient temperature have an effect on the viscosity and on the density of the fill fluid. The change in viscosity has a direct effect on the response time of the Diaphragm Seal System. The change in density creates a mounting effect in case of a vertical height difference which results in a zero-point deviation of the Diaphragm Seal System.
- **Delta T in DP measurement:** Temperature effects can cause a difference in density or viscosity between the HP side and LP side of the Diaphragm Seal System.

CALCULATED TEMPERATURE EFFECTS

The Diaphragm Seal System’s volume consists of three components: Diaphragm Seal chamber volume, capillary volume, and the pressure instrument volume. The table below presents the temperature effect in mbar for each of the components. The values for each component in the table need to be added to arrive at the total temperature effect for the Diaphragm Seal System.

DP transmitter with two Diaphragm Seals

Diaphragm Size	Transmitter (mbar)	Seal (mbar)	Capillary (mbar/mtr)
44mm	0.62	0.91	1.62
51mm	0.10	0.76	1.19
57mm	0.02	0.24	0.41
72mm	0.01	0.11	0.12
81mm	0.01	0.08	0.07

Temperature effect per 10°C

GP/AP transmitter with Diaphragm Seal

Diaphragm Size	Transmitter (mbar)	Seal (mbar)	Capillary (mbar/mtr)
17mm	300	300	1600
20mm	150	150	800
23mm	85	84	409
32mm	20	17	17
44mm	3.11	4.56	8.10
51mm	0.52	3.79	5.95
57mm	0.12	1.22	2.04
72mm	0.03	0.53	0.62
81mm	0.02	0.39	0.35
LGP	0.02	0.09	0.03

Temperature effect per 10°C

Pressure Gauge with Diaphragm Seal below 60 bar

Diaphragm size	Pressure Gauge (mbar)			Seal (mbar)	Capillary (mbar/mtr)
	63mm	100mm	160mm		
32mm	63	256	-	17	17
44mm	13	52	90	4.6	8.1
57mm	4.0	15	25	3.8	2.0
72mm	1.0	4.0	8.0	0.5	0.6
81mm	0.4	2.0	3.0	0.4	0.4

Temperature effect per 10°C

Pressure Gauge with Diaphragm Seal above 60 bar

Diaphragm size	Pressure Gauge (mbar)			Seal (mbar)	Capillary (mbar/mtr)
	63mm	100mm	160mm		
32mm	32	128	-	17	70
44mm	6.5	26	45	4.6	8.1
57mm	2.0	7.5	13	3.8	2.0
72mm	0.5	2.0	8.0	0.5	0.6
81mm	0.2	1.0	3.0	0.4	0.4

Temperature effect per 10°C

Testing variables:

- Reference temperature 20°C
- Inside capillary diameter 2mm
- Diaphragm stainless steel AISI 316(L)
- Filling fluid is BSO-22
- Transmitter volume is an average of various transmitters brands
- Diaphragm Seal and instrument are at same height

EXAMPLE CALCULATION:

DP transmitter with two 3” seals (81mm diaphragm) and 5 meter capillary.

- Transmitter: 0.01 mbar
- Seal: 0.08 mbar
- Capillary: 0.35 mbar (5x0.07)
- **Worst case effect: 0.44 mbar / 10°C**

MINIMISING TEMPERATURE EFFECTS

Temperature effects can be minimised by using the following techniques:

- **Reduce the volume of the application:** This can be done with reducing the capillary internal diameter (ID). However, reducing the capillary ID increases the response time for the application and in this a balance needs to be found. Badotherm standardly uses 2mm as inside diameter of the capillary. Switching to capillary with ID of 1 mm will increase the response time with a factor 16. Capillary with 1mm inside diameter is advised for gauge pressure applications with a range above 100 barg. It is also important to minimise the volume of fill fluid contained in the pressure instrument to a minimum. This can be done by replacing the standard process covers of a transmitter by special designed low volume covers, or to use pressure gauge with a reduced volume.
- **Specify the shortest possible capillary lengths for the application:** it is understandable that for interchangeable reasons the capillary lengths for all LT tags in a project are specified with the same length. It is advised that capillary lengths should be calculated on a tag by tag basis to define the shortest possible length for each tag. Too long capillaries will result in unacceptable response times and/or too high temperature influences with all consequences for the reliability of the measurement.
- **Cold temperature application:** there are processes where, due to a system of both low ambient and process temperatures, the contraction of fill fluid is as such that the diaphragm runs against the diaphragm chamber and transfer of pressure is no longer possible. A solution for these situations is a so-called 'supplementary fill' which allows for pressure transfer even when the fill fluid heavily contracts.
- **Insulation of Diaphragm Seal System:** in cases where both capillaries and Diaphragm Seals are exposed to severe outdoor conditions, insulating them will reduce ambient temperature effects considerably. Also in those cases where the capillary of one leg of a DP system is in the sun and the other leg in the shadow insulating them will result in the same or similar ambient temperature at both legs and minimises ambient temperature effects.
- **Tracing of capillaries:** this will reduce ambient temperature effects close to zero. Often tracing is considered expensive and requires intensive maintenance. However, a new development is that Badotherm is working together with O'Brien to include the product Tracepak around capillary lines already at the time of assembly of the Diaphragm Seal system.
- **High temperature process and temperature reducers:** in those processes with high temperatures (> 200°C) and where distant mounting by means of capillary is not possible, a temperature reducer (TR) can be foreseen between instrument and Diaphragm Seal. A temperature reducer reduces process temperatures to a value < 100°C at the instrument side.
- **Temperature compensator:** when the specifications of the process prescribe the use of a fill fluid with high viscosity this might result in unacceptable response times. A temperature compensator (TC) is developed to overcome this problem. By using the high viscous fill fluid in the part between seal diaphragm and TC, the fluid keeps a relative high temperature resulting in a low viscosity; after the TC a standard fill fluid with low viscosity is used resulting in an acceptable overall response time.
- **Process simulation:** Badotherm offers the possibility of a full process simulation. The Diaphragm Seal System is simultaneously subjected to: process temperature, ambient temperature, and static process pressure. Their respective influences on the calibrated (DP) span are recorded. This results in a fingerprint for this specific Diaphragm Seal System and the influences can be incorporated into the DCS to compensate for the effects. The result is a pressure (level) measurement with enhanced accuracy.
- **LGP solution:** is designed for Low Gauge Pressure measurement and eliminates temperature and mounting influences. Test results obtained by measuring low gauge pressures with a standard Diaphragm Seal and with the LGP, showed that the minimum range reduces from 80 mbar for a standard seal to only 10 mbar with the LGP. Similarly the ambient temperature effect reduces from 0.4 mbar per 10°C to 0.03 mbar, while the process temperature effect reduces from 0.39 to 0.09 mbar.

INTRODUCTION

Instruments with Diaphragm Seals can be mounted in various positions. In a differential pressure measurement the instrument can be mounted between the nozzles, but the instrument can also be mounted above the highest or below the lowest nozzle. Also in a gauge pressure measurement the instrument can be mounted in various positions compared to the Diaphragm Seal.

The mounting of the instrument is important to ensure the best possible measurement in the given circumstances. The specific gravity of the vertical fill fluid column between the instrument and the Diaphragm Seal is influenced by the ambient temperature deviation. These influences create a pressure variation within the Diaphragm Seal System. This is called the mounting effect.

SHIFT IN ZERO POINT

When the exact mounting details of the transmitter and the Diaphragm Seal are not known at calibration, the span is set from zero to the required value (e.g. 0-400 mbar). When mounting the Diaphragm Seal System in the field, the zero can shift depending on how it is mounted. This is caused by the gravity effect after installation. This shift can be zero suppression or zero elevation.

ZERO SUPPRESSION:

the factory calibrated zero is shifted above zero after installation (e.g. 150 + 550 mbar)

ZERO ELEVATION:

the factory calibrated zero is shifted below zero after installation (e.g. -390 + 10 mbar)

The shift in zero point can be calculated with the density of the Badotherm fill fluid, the height difference of the installed application, and the gravity. The shift in zero point is important to know prior to installation because the shift must remain within the limits of the transmitter range. If the zero shift is outside the limits of the transmitter range, the transmitter will fail to measure.

Badotherm Diaphragm Seals have a minimum working pressure of 1 mbara, depending on the filling fluid. Please consider the minimum static or working pressure of the pressure instrument that is mentioned in the brand specific documentation.

DIFFERENTIAL PRESSURE APPLICATIONS

Differential pressure applications can be used for various purposes: differential pressure, level, flow, density, and interface measurements. There are three different mounting styles for level to be recognised, depending on the position of the instrument compared to the Diaphragm Seal.

- **DP STYLE 1:** instrument between the Diaphragm Seals
- **DP STYLE 2:** instrument below the Diaphragm Seals
- **DP STYLE 3:** instrument above the Diaphragm Seals

DP Style 1: instrument between the Diaphragm Seals

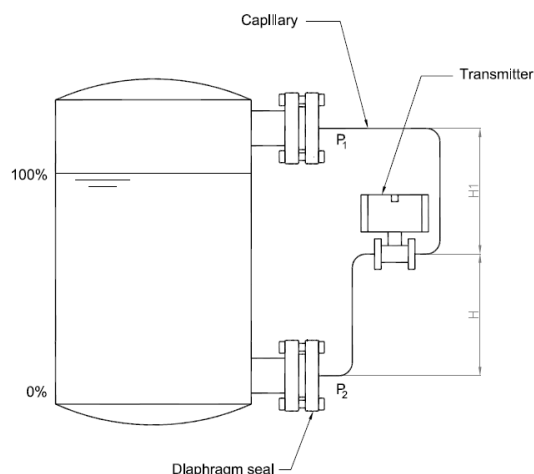

DP Style 2: instrument below the Diaphragm Seals

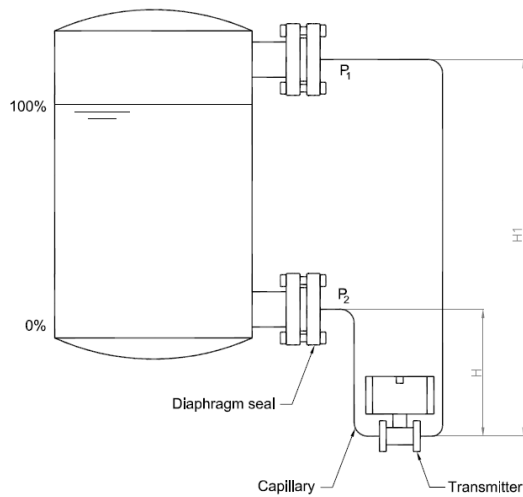

- Ease of installation
- Accessibility of the instrument: reading of local display and maintenance
- Obstacles that do not allow to place the instrument elsewhere

However, the process conditions should be considered first whilst selecting one of the mounting styles. The following example illustrates this.

Suppose DP Style 3 has been selected because the vessel is positioned below the walking grid ($H_1=360\text{cm}$). The fill fluid (density $1,020\text{ kg/m}^3$) column in the capillary that connects the lowest seal (P_2) with the DP instrument, represents a pressure of ($p=h*\rho*g$): $0,360*1,020*9.81 = 360,2\text{ mbar}$. This hydrostatic pressure is sensed at the DP instrument as a negative pressure, $-360,2\text{ mbar}$. When in this application the minimum operating pressure is as low as -800 mbar (200 mbar), the selected mounting by style 3 will damage the Diaphragm Seal System: $-360,2 - 800\text{ mbar} = -1160,2\text{ mbar}$. This implies a pressure below absolute zero which is impossible. This will either damage the diaphragm of the seal or the diaphragm of the DP instrument. Also, the fill fluid can be damaged because it is pushed over the limits of its vapour pressure.

DP Style 3: instrument above the Diaphragm Seals

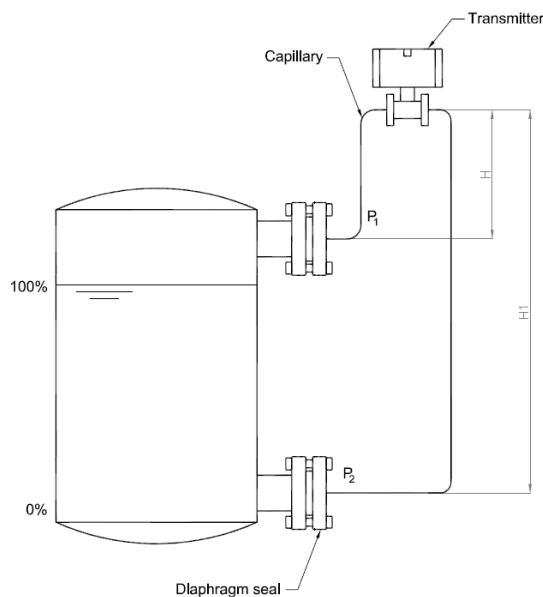

In this example DP Style 2 would have been the better option. The transmitter is then placed below the vessel ($H=160\text{CM}$) and the hydrostatic pressure is then: $0,160*1,020*9.81 = 160,1\text{ mbar}$. This is sensed at the DP instrument as a positive pressure $+160,1\text{ mbar}$. With the minimum operating pressure of -800 mbar , it would result in a pressure at the instrument of $-800 + 160,1 = -639,9\text{ mbar}$. This is well above absolute zero, and thus the instrument and Diaphragm Seal System will function properly.

Each style has specific advantages, limitations, and considerations that should be taken into account. DP Styles 1 and 3 only allows limited vacuum and DP Style 2 allows for full vacuum (1mbar), when 'H' is at least 50 cm . The selection of one of the above indicated mounting styles is often driven by:

GAUGE PRESSURE APPLICATIONS

Gauge pressure applications can be used for pressure, level, and density measurement. Also for this application there are three different styles to be recognised depending on the position of the instrument compared to the Diaphragm Seal.

- **GP STYLE 1:** instrument equal to the Diaphragm Seal
- **GP STYLE 2:** instrument below the Diaphragm Seal
- **GP STYLE 3:** instrument above the Diaphragm Seal

The effect of the mounting on a GP instrument is similar as described for the DP instrument. When an instrument is placed above the seal, it will sense this as a negative pressure and that pressure, in combination with the minimum operating pressure, should not exceed a value below absolute zero. The Diaphragm Seal System would be damaged in a similar way as described for DP applications.

GP Style 1: instrument equal to the Diaphragm Seal

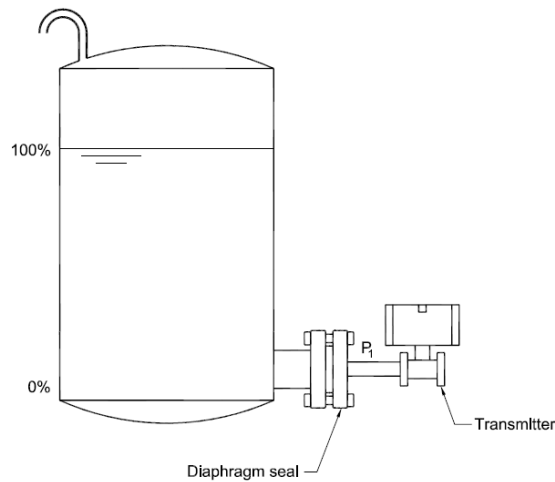

GP Style 2: instrument below the Diaphragm Seal

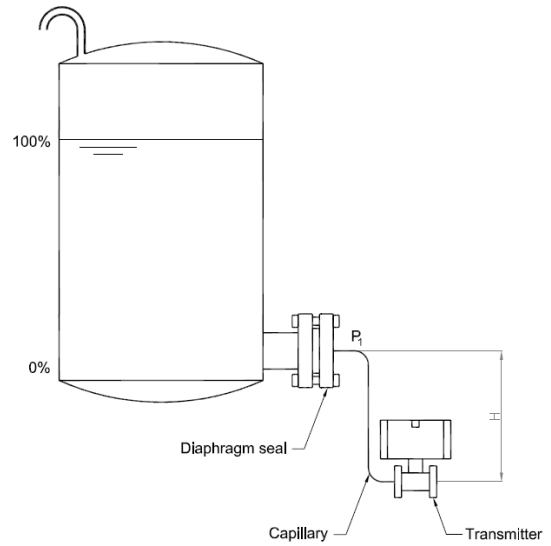

GP Style 3: instrument above the Diaphragm Seal

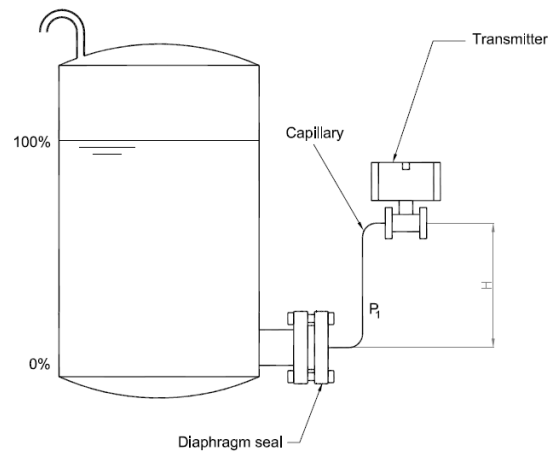

ABSOLUTE PRESSURE APPLICATIONS

Absolute pressure applications are only used to measure pressure. For this application there can be also three different styles recognised depending on the position of the instrument compared to the Diaphragm Seal.

- **AP STYLE 1:** instrument equal to the Diaphragm Seal
- **AP STYLE 2:** instrument below the Diaphragm Seal
- **AP STYLE 3:** instrument above the Diaphragm Seal

For absolute pressure measurement the instrument should be mounted below the diaphragm seal in order to protect the instrument at all possible conditions. This is presented in AP Style 2. If for example $H=50\text{cm}$ the pressure on the instrument is already above 50 mbar. With this mounting style the instrument has additional protection before it reaches absolute zero. AP Style 1 is also possible, but not preferred as there is no additional protection so it is possible to reach the absolute zero and damage the application.

AP Style 1: instrument equal to the Diaphragm Seal

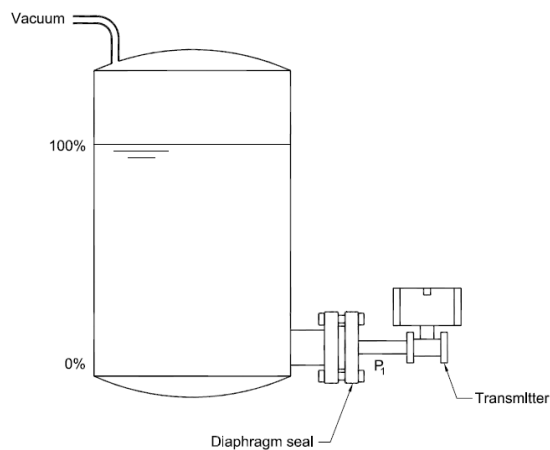

AP Style 2: instrument below to the Diaphragm Seal

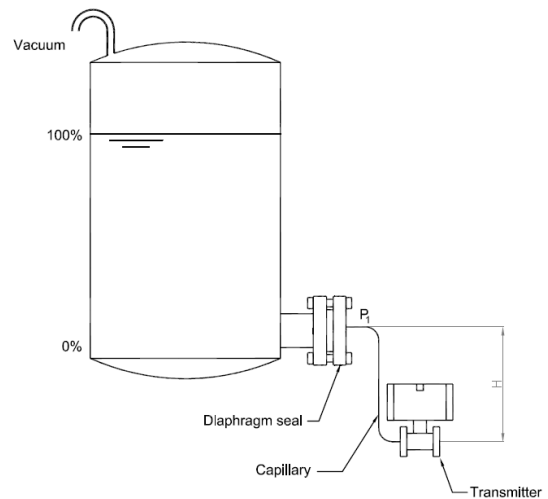

Mounting the instrument above the Diaphragm Seal (AP Style 3) will damage the Diaphragm Seal System in a similar way as described under DP applications. Care should be taken, when an instrument is direct mounted on the Diaphragm Seal and installed as shown in AP Style 3. As a standard, Badotherm uses a distance tube of 80 mm. With a silicon BSO fill fluid, this will create a negative pressure of approximately 8 mbar at the pressure sensor. When the absolute pressure runs below 8 mbara, the Diaphragm Seal or instrument will be damaged.

AP Style 3: instrument above to the Diaphragm Seal

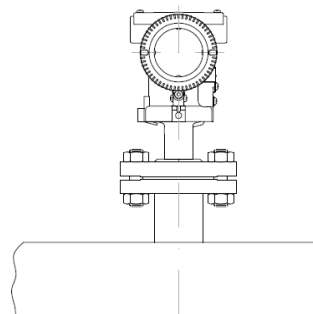

DIAPHRAGM SEALS AND WET LEGS

A wet leg is made with tubing mounted directly to the transmitter and is filled with process medium. Diaphragm Seal Systems offer significant installation flexibility and maintenance advantages over wet leg systems. Diaphragm Seals make it easier to maintain the fluid between the tap and the transmitter, especially on the reference or low pressure side. In vacuum systems, a closed seal system, rather than an open wet leg, maintains a constant height for the low side reference. The Diaphragm Seal System does not need to be refilled or drained. They are also not vulnerable to plugging or freezing and they are easier to control than wet leg systems.

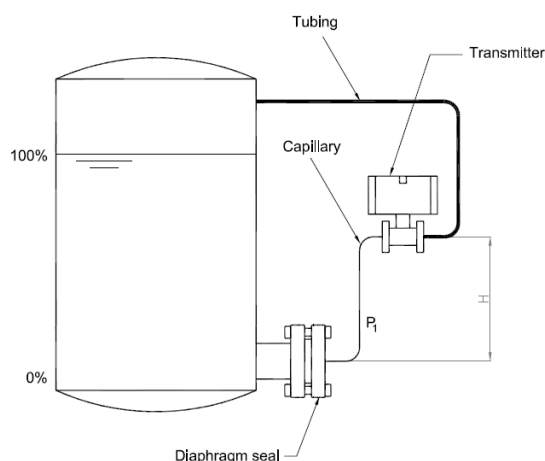
**BALANCED SYSTEM**

A balanced system means that the volume of the Diaphragm Seal System is equal at the HP and LP side of the DP measurement. This can be obtained by ensuring that the fill volume in the Diaphragm Seal and the capillary lengths are similar at both sides. An unbalanced system can be equipped with two different sized diaphragms and/or with using two different lengths of capillary. This results in a larger volume of fill fluid on one side compared to the other side.

A balanced Diaphragm Seal System is preferred above an unbalanced system because it reduces or avoids the effect mentioned next:

- **Ambient temperature effects:** as a result of ambient temperature changes balanced systems will have equal expansion and/or contraction of fill fluid. As both sides are equal the effect on the DP transmitter will be zero or close to zero. Unbalanced systems have a different expansion and/or contraction of fill fluid on either side due to ambient temperature changes. This results in a different pressure build up (expansion) or drop (contraction) which negatively influences the accuracy of the overall measurement.
- **Process temperatures effects:** For applications with an elevated process temperature (>65°C) the effect of an unbalanced system can be considerable. For example there is an unbalanced system with a direct mounted Diaphragm Seal to the HP side and a capillary mounted to the LP side. The heat transfer from the process temperature to the direct mount on the HP side of the instrument will be higher than to capillary mount on the LP side of instrument. This results in a different pressure build up (expansion) which negatively influences the accuracy of the overall measurement.
- **Static pressure effects:** In case of fluctuating static pressures unbalanced systems can become unstable because the static pressure will be transferred faster to the side with the lowest volume.

REDUCTION OF MEASUREMENT ERRORS

There are different ways to minimise the measurement errors of the Diaphragm Seal System:

- Keep capillary lengths as short as possible
- Use capillaries of the same length on both taps when measuring differential pressure
- Use diaphragms with the same diameter
- Never mount seals and capillaries in direct sunlight
- Ensure that both capillaries experience the same temperature. For instance, avoid installing one capillary in a shady area and the other in the sun

OVERVIEW OF TYPES OF DIAPHRAGM SEALS

Once performance needs, process conditions, and installation requirements are known, the individual seal components can be selected. The following pages describe the available seal types, the system assembly options,

and fill fluid characteristics. Badotherm offers a complete variety of Diaphragm Seals to meet application needs.

FLANGED DIAPHRAGM SEALS

These types of diaphragm seals are designed for either direct mounting on the process flange or by clamping the seal between process flange and a cover flange.

They are available in all kinds of international flange standards, ASME B16.5, EN1092-1, API 6A ISO 10423 or JIS B2220.

BF

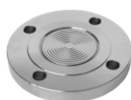

- 30 The BF construction has a seal body that is made of a blind flange. The weld of the diaphragm to the seal body is a wetted part and therefore diaphragm materials are mostly chosen the same as the flange material.

BRF



- 35 The BRF construction has a seal body that is made of a blind flange and is designed to obtain a diaphragm seal with full wetted parts in exotic materials. With Badotherm unique resistance weld technology, a stainless steel body (non-wetted) has its wetted parts (diaphragm and raised face area) covered by sheet material in the required exotic material.

BC



- 38 The BC construction has a seal body that is made of bar stock or forged material. The weld of the diaphragm to the seal body is a wetted part and therefore diaphragm materials are mostly chosen the same as the flange material. Its pressure rating is defined by the back-up flange and as such it can be used for all pressure ratings in RF or type B1 facings.

BRC

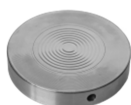

- 41 The BRC construction is designed to obtain a diaphragm seal with full wetted parts in exotic materials. With Badotherm unique resistance weld technology, a stainless steel body (non-wetted), has its wetted parts (diaphragm and raised face area) covered by sheet material in the required exotic material. Its pressure rating is defined by the back-up flange and as such it can be used for all pressure ratings in RF or type B1 facings.

EXT



- 43 EXT (extended) construction is typically used when the diaphragm needs to be flush with the vessel wall or where insulation layers need to be passed. The weld of the diaphragm to the seal body is a wetted part and therefore diaphragm materials are mostly chosen the same as the flange material.

USF



- 46 The USF construction is designed for those applications where the existing process connection is too small to use a flush diaphragm seal. The USF consists of an upper and lower housing. The lower housing creates the transition from the diaphragm size to the actual small process connection.

USLF



- 48 The USLF construction has a larger diaphragm with a better performance than the USF and is designed for those applications where the existing process connection is too small to use a flush diaphragm seal. The lower housing creates the transition from the diaphragm size to the actual small process connection.

FLANGED SLIP ON (FSO) DIAPHRAGM SEALS

The FSO construction is used when special flange grades are required and keep the use of exotic material limited

to the wetted parts, but only for groove type gasket facings.

FSO-BF



50 The FSO-BF construction has a seal body that is made of bar stock or forged material. The weld between the seal body and the diaphragm is a wetted part and therefore diaphragm materials are mostly chosen the same as the body material. The FSO-BF is recommended when special body or flange material grades are required.

FSO-BRF



55 The FSO-BRF construction is designed to obtain a diaphragm seal with full wetted parts in exotic materials. With Badotherm unique resistance weld technology, a stainless steel body (non-wetted), has its wetted parts (diaphragm and raised face portion) covered by sheet material in the required exotic material. FSO-BRF is recommended when special flange grades are required.

FSO-EXT



58 FSO-EXT is typically used in when the diaphragm needs to be flush with the vessel wall or where insulation layers need to be passed. The FSO-EXT is recommended when extended seals are required fully in exotic materials and/or when special grade flanges are required.

THREADED DIAPHRAGM SEALS

These types of diaphragm seals are designed for direct mounting on the threaded process connection. They are

available in all kind of international thread standards, NPT, BSP, and metric.

UST



60 The UST construction is designed for those situations where the existing threaded process connection is too small to use a flush diaphragm seal. The upper part is the seal part with a diaphragm size that allows for proper measurement. The lower housing enables the transition to the actual small process connection.

USLT



62 The USLT construction has a larger diaphragm with better performance as the UST and is designed for those applications where the existing process connection is too small to use a flush diaphragm seal. The upper part is the seal part with a diaphragm size that allows for proper measurement. The lower housing enables the transition to the actual small process connection.

ECx



64 The ECx is a welded type construction and designed for those applications where the process conditions are such that direct mounting of the instrument cannot be done. Applications are viscous media, waste water treatment, or when special wetted parts materials for pressure gauges are required. ECx is typically used in combination with pressure gauges.

PS



67 The PS construction is designed for those applications where the process is very viscous and/or containing parts that might obstruct the process connection of the instrument. Typical applications can be found in pulp & paper industries and waste water treatment. The PS is a single part construction.

SANITARY DIAPHRAGM SEALS

Sanitary seals are designed for pressure, level and flow measurements in food & beverage, and pharmaceutical industries where the formation of bacteria needs to be prevented by reducing or eliminating blind spaces where

process product could remain and thus creating impurities, bacteria by e.g. fermentation. As such these seals allow for easy cleaning by means of either threaded or clamped quick couplings.

SA



69 Sanitary seals are designed for food and pharmaceutical industries where the formation of bacteria needs to be prevented by reducing or eliminating blind spaces where process product could remain and thus creating impurities, bacteria by e.g. fermentation. These seals are standard in stainless steel AISI 316(L). Common connections are DIN 11851 / SMS 1145 and TRI-CLAMP ISO – 2852/ DN 32676.

ILS



74 ILS is typically used in combination with pressure transmitters for pressure measurement (≥ 2 barg) applications. Its pressure rating is defined by the connections between which it is clamped and as such it can be used for all pressure ratings.

SPECIAL DIAPHRAGM SEALS

Some applications require non-standard diaphragm seals. Badotherm has developed several Diaphragm Seals seal that can withstand extreme process condi-

tions, or diaphragm seals that require specially designed connections.

HTDS



76 The HTDS is a Diaphragm Seal that can meet process temperatures up to 600°C. To enable a proper functioning of the Diaphragm Seal at these extreme process temperatures a revolutionary new design and principle is used. The novelty of the design is as such that Badotherm has a Patent on the High Temperature Diaphragm Seal (HTDS).

BHS



79 Badotherm Hub seal is a special design based on high pressure clamp so called hub connectors such as Destec® or Galperti®. These type of connectors are designed for high pressure applications (>400 bar) where standard flanges cannot be used or only with extreme heavy weight, since another advantage of the Hub connector is the relative small design with a far lower load on the process installation.

SJ



81 SJ is typically used in those applications where the diaphragm needs to be flush with the pipe wall. This can be obtained by either mounting the SJ seal part in a saddle type that is welded on top of the piping or in a flow through block that can be welded into the piping or mounted by means of flanges. Typical applications are pressure measurements of highly viscous media.

BHP







84 The BHP construction is designed for those applications the process pressure is very high. The construction is executed with a stainless steel sensing element welded in bar stock material which is designed to withstand these high pressures up to 4000 bar.

FLUSH RINGS, FLUSH FLANGES, AND REDUCER FLANGES

The flushing flange or ring is used for flushing solution combined with diaphragm seals. This type of flushing flange or ring is clamped between process nozzle and diaphragm seal. The reducer flange is used to mount a





larger diaphragm seal to a smaller process connection. This type of reducer flange is bolted between process nozzle and diaphragm seal.

FLUSH FLANGE		104	Flushing flange is used for flushing solution combined with diaphragm seals. This type of flushing ring is clamped between process nozzle and diaphragm seal and aligned by the exact same bolt holes as the process nozzle and the diaphragm seal. The flushing flange can be combined with the BF and BRF seal.
FLUSH RING		107	Flushing ring is used for flushing solution combined with diaphragm seals. This type of flushing ring is clamped between process nozzle and diaphragm seal. The flushing ring can be combined with the BF and BRF seal as well as the BC and BRC type.
REDUCER FLANGE		111	Reducer flange is used to mount a larger diaphragm seal to a smaller process connection. This type of reducer flange is bolted between process nozzle and diaphragm seal. Eccentric reducer flanges can be supplied to prevent process media remaining in the reducer ring when mounted in vertical position. The reducer flange can be combined with the BF and BRF seal as well as the BC and BRC type.
FLUSH & VALVE		104-111	Flush rings or flanges can be supplied with valves fitted or welded, and tested.

DIAPHRAGM SEAL ACCESSORIES

Diaphragm Seal Accessories are carefully designed to optimise the use of the Diaphragm Seal in your process

conditions, or to ease the installation and protect it against damaging during installation.

SUPPORT HANDLES		113	Support handles are available for 2” and 3” Diaphragm Seals and flush flanges to assist in easy handling during installation.
SUPPORT TUBE		113	Heavy duty support tube is available for all capillary connections on Diaphragm Seals and provides additional protection and increases the durability.
TEMPERATURE REDUCER		114	Temperature reducer is used to protect the instrument from high process temperatures and is used in combination with direct mounted Diaphragm Seals.
TEMPERATURE COMPENSATOR		114	Temperature compensator is used to lower the response time in combination with long capillaries and high or low temperatures.

Flanged Diaphragm Seals

Process Connection size		BF	BRF	EXT	BC	BRC	US-F	USL-F	FSO-BF	FSO-EXT	FSO-BRF	ILS-F
ASME B16.5	EN1092-1											
½"	DN15						●	●				
¾"	DN20						○	○				
1"	DN25	●	●		○	○	●	●	●		●	●
1,25"	DN32	○	○				○	○	○		○	
1,5"	DN40	●	●		○	○	●	●	●		●	●
2"	DN50	●	●	●	●	●	●	●	●	●	●	●
2,5"	DN65	○	○	○	○	○	○	○	○	○	○	○
3"	DN80	●	●	●	●	●	●	●	●	●	●	●
4"	DN100	●	●	●	●	●			○	●	●	●
5"	DN125											●
6"	DN150											●
JIS B2220		●	●	●	●	○	○	○	○	○	○	
API 6A ISO 10423		●			○				○			

Process Connection Rating		BF	BRF	EXT	BC	BRC	US-F	USL-F	FSO-BF	FSO-EXT	FSO-BRF	ILS-F
ASME B16.5												
<i>cl. 150-2500</i>					●	●						●
<i>cl. 150</i>		●	●	●	○	○	●	●	●	●	●	
<i>cl. 300</i>		●	●	●	○	○	●	●	●	●	●	
<i>cl. 400</i>		●	●	●	○	○	●	●	●	●	●	
<i>cl. 600</i>		●	●	●	○	○	●	●	●	●	●	
<i>cl. 900</i>		●	○	●	○	○	●	○	●	●	○	
<i>cl. 1500</i>		●	○	●	○	○	●	○	●	●	○	
<i>cl. 2500</i>		●	○	●	○	○			●	●	○	
EN 1092-1												
<i>PN10-400</i>					●	●						●
<i>PN2,5</i>		○	○	○	○	○	○	○	○	○	○	
<i>PN6</i>		○	○	○	○	○	○	○	○	○	○	
<i>PN10</i>		●	○	○	○	○	○	○	○	○	○	
<i>PN16</i>		●	○	○	○	○	○	○	○	○	○	
<i>PN25</i>		●	○	○	○	○	○	○	○	○	○	
<i>PN40</i>		●	●	●	○	○	●	●	○	○	○	
<i>PN63</i>		●	○	○	○	○	○	○	○	○	○	
<i>PN100</i>		●	○	○	○	○	○	○	○	○	○	
<i>PN160</i>		○	○	○	○	○	○	○	○	○	○	
<i>PN250</i>		○	○	○	○	○	○	○	○	○	○	
<i>PN400</i>		○	○	○	○	○			○	○	○	
JIS B2220		●	●	●	●	○	○	○	○	○	○	
API 6A ISO 10423		●			○				○			

Flange Facings		BF	BRF	EXT	BC	BRC	US-F	USL-F	FSO-BF	FSO-EXT	FSO-BRF	ILS-F
ASME B16.5												
<i>Raised Face (RF)</i>		●	●	●	●	●	●	●	●	●	●	●
<i>Ring Joint Face (RJF)</i>		○		○	○	○	○	○	○	○	○	○
<i>Large Male Face (LMF)</i>		○	○	○	○	○	○	○	○	○	○	○
<i>Small Male Face (SMF)</i>		○	○	○	○	○	○	○	○	○	○	○
<i>Flat Face (FF)</i>		○	○	○			○	○				
<i>Large Tongue Face (LTF)</i>		○		○	○	○	○	○	○	○		
<i>Small Tongue Face (STF)</i>		○		○	○	○	○	○	○	○		
<i>Large Groove Face (LGF)</i>		○		○	○	○	○	○	○	○		
<i>Small Groove Face (SGF)</i>		○		○	○	○	○	○	○	○		
<i>Large Female Face (LFF)</i>		○					○	○	○			
<i>Small Female Face (SFF)</i>		○					○	○	○			
1092-1												
<i>Type A</i>		○	○	○			○	○				○
<i>Type B1</i>		●	●	●	●	●	●	●	○	○	●	●
<i>Type B2</i>		○	○	○	○	○	○	○	○	○	○	○
<i>Type C</i>		○		○	○	○	○	○	○	○	○	○
<i>Type D</i>		○		○	○	○	○	○	○	○	○	○
<i>Type E</i>		○		○	○	○	○	○	○	○	○	○
<i>Type F</i>		○		○	○	○	○	○	○	○	○	○
<i>Type G</i>		○					○	○	○			○

● = standard / ○ = optional

Flange Facings	BF	BRF	EXT	BC	BRC	US-F	USL-F	FSO-BF	FSO-EXT	FSO-BRF	ILS-F
Type H	○					○	○	○			○
JIS											
FF	○	○	○	○	○	○	○	○	○	○	○
RF	●	●	●	●	●	●	●	○	○	●	●
MFM	○	○	○	○	○	○	○	○	○	○	○
MFF	○		○	○		○	○	○	○		○
TGT	○		○	○		○	○	○	○		○
TGG	○		○	○		○	○	○	○		○
API											
6BX - RJF	●			○							
6B - RJF	●			○							

Diaphragm Material	BF	BRF	EXT	BC	BRC	US-F	USL-F	FSO-BF	FSO-EXT	FSO-BRF	ILS-F
AISI 316(L) UNS S 31603	●		●	●		●	●	●	●		●
Monel 400 UNS N 04400	○ ¹	○	○ ¹	○ ¹	○	○	○	○ ¹	○ ¹	○	
Hastelloy C-276 UNS N 10276	○	●	○	○	●	○	○	○	○	●	○
Hastelloy B2 UNS N 10665	○ ¹	○	○ ¹	○ ¹	○	○	○	○ ¹	○ ¹	○	
Tantalum UNS R 05200		○			○	○	○				○
Nickel 201 UNS N 00201		○		○ ¹	○			○ ¹	○ ¹	○	
Niobium UNS R 04200		○			○						○
AISI 321 UNS S 32100	○	○	○	○	○	○	○	○	○	○	○
Duplex 2205 UNS S 31803	○ ¹	○	○ ¹	○ ¹	○	○	○	○ ¹	○ ¹	○	
Titanium Gr. 1 UNS R 50250				○ ¹		○ ¹	○ ¹	○ ¹	○ ¹		
Inconel 600 UNS N 06600	○ ¹	○	○ ¹	○ ¹	○	○	○	○ ¹	○ ¹	○	
AISI 304(L) UNS S 30403	○	○	○	○	○	○	○	○	○	○	○
AISI 316 UG UNS S 31603	○	○	○	○	○	○	○	○	○	○	○

¹) complete body material

Body Material	BF	BRF	EXT	BC	BRC	US-F	USL-F	FSO-BF	FSO-EXT	FSO-BRF	ILS-F
AISI 316(L) UNS S 31603	●	●	●	●	●	●	●	●	●	●	●
Monel 400 UNS N 04400	○		○	○		○	○	○	○		
Hastelloy C-276 UNS N 10276	○		○	○		○	○	○	○		
Duplex F51 UNS S 31803	○	○	○	○	○	○	○	○	○		
Super Duplex F53 UNS S 32750	○		○	○		○	○	○	○		
Inconel 600 UNS N 06600	○		○			○	○	○	○		
Titanium Gr. 2 UNS R 50400				○		○	○	○	○		
Nickel 201 UNS N 00201				○				○	○		

Coatings	BF	BRF	EXT	BC	BRC	US-F	USL-F	FSO-BF	FSO-EXT	FSO-BRF	ILS-F
Gold Coating 25 µm / 40 µm											
Hydrogen Permeation (H++)	○		○	○		○	○	○	○		
H++ and Chemical Resistance	○			○				○	○		
PTFE / ECTFE 40-50 µm for anti-stick	○		○			○ ²	○ ²	○	○		
Tantaline treatment	○		○	○		○	○	○	○		
PFA / FEP	○	○	○	○	○	○ ²	○ ²	○	○	○	
Thermal spray (excl. diaphragm)	○	○		○	○	○	○	○	○	○	

²) upper part only

Other options	BF	BRF	EXT	BC	BRC	US-F	USL-F	FSO-BF	FSO-EXT	FSO-BRF	ILS-F
Set of handles welded on side	○	○	○								
Heavy duty capillary tube (IP54/IP68)	○	○	○	○	○	○	○	○	○		○
TR - Temperature reducer	○	○	○			○	○	○	○		○
TC - Temperature compensator	○	○	○			○	○	○	○	○	○
Capillary side mounted (radial)	○	○		●	●						●
Flushing rings or flanges	○	○		○	○			○		○	
LGP execution	○	○					○				
PTFE sheet for anti-stick						○	○				
¼" NPT-f flush ports in lower part						○	○				
Gasket Virgin PTFE						●	●				
Gasket Garfite N						○	○				
Gasket camprofile graphite						○	○				
Polished extension			○								
Lining in lower part						○	○				

● = standard / ○ = optional

Threaded, Sanitary, and Special Diaphragm Seals

Process Connection size		US-T	USL-T	ECx	PS	SA-F/M	SA-T	TS	SA-V	HOM	BHS
NPT-m / f	¼ ½ ¾ 1"	●	●	●							
BSP-m / f	¼ ½ ¾ 1"	●	●	●							
NPT-m	1" 1,5" 2"				●						
ISO228 m	1" 1,5" 2"				●						
ISO228 m / f	¼ ½ 1"	○	○	○							
Metric m / f	M12x1,5 M20x1,5	○	○	○							
DIN 11851	DN25-DN80 M/F					●					
SMS 1145/IDF 2853/RJF	1,5"-3" M/F					○					
Tri clamp ISO2852	1,5 - 4" M/F						●				
Sanitary Tank spud	5" clamp							●			
Homogeniser	clamping flange									●	
Varivent	Type N								●		
Hub connection											●

Diaphragm Material		US-T	USL-T	ECx	PS	SA-F/M	SA-T	TS	SA-V	HOM	BHS
AISI 316 (L)	UNS S 31603	●	●	●	●	●	●	●	●	●	●
Monel 400	UNS N 04400	○	○	○ ¹	○ ¹						
Hastelloy C-276	UNS N 10276	○	○	○ ¹	○ ¹						
Hastelloy B2	UNS N 10665	○	○								
Tantalum	UNS R 05200	○	○								
Nickel 201	UNS N 00201	○	○								
Niobium	UNS R 04200	○	○								
AISI 321	UNS S 32100	○	○								
Duplex 2205	UNS S 31803	○	○	○ ¹	○ ¹						
Titanium Gr. 1	UNS R 50250	○ ¹	○ ¹								
Inconel 600	UNS N 06600	○	○								
AISI 304 (L)	UNS S 30403	○	○								
AISI 316 UG	UNS S 31603	○	○								

¹) complete body material

Body Material		US-T	USL-T	ECx	PS	SA-F/M	SA-T	TS	SA-V	HOM	BHS
AISI 316 (L)	UNS S 31603	●	●	●	●	●	●	●	●	●	●
Monel 400	UNS N 04400	○	○	○							
Hastelloy C-276	UNS N 10276	○	○	○	○						○
Duplex F51	UNS S 31803	○	○	○	○						○
Super Duplex F53	UNS S 32750	○	○	○	○						
Inconel 600	UNS N 06600	○	○								
Titanium Gr. 2	UNS R 50400	○	○								

Coatings		US-T	USL-T	ECx	PS	SA-F/M	SA-T	TS	SA-V	HOM	BHS
Gold Coating 25 µm / 40 µm		○	○								
Hydrogen Permeation (H++)		○	○								
H++ and Chemical Resistance											
PTFE / ECTFE 40-50 µm for anti-stick		○ ²	○ ²								
Tantaline treatment		○	○	○	○	○	○	○	○	○	○
PFA / FEP		○ ²	○ ²								

²) upper part only

Other options		US-T	USL-T	ECx	PS	SA-F/M	SA-T	TS	SA-V	HOM	BHS
Heavy duty capillary tube (IP54/IP68)		○	○								
TR - Temperature reducer		○	○								
TC - Temperature compensator			○								
LGP execution			○								
PTFE sheet for anti-stick		○	○								
¼" NPT-f flush ports in lower part		○	○								
Gasket Virgin PTFE		●	●								
Gasket Garfite N		○	○								
Gasket camprofile graphite		○	○								
Lining in lower part		○	○								

● = standard / ○ = optional

The BF construction has a seal body that is made of a blind flange. The weld of the diaphragm to the seal body is a wetted part and therefore diaphragm materials are mostly chosen the same as the flange material. The BF is typically used in combination with (differential) pressure transmitters for applications such as level, flow and (absolute) pressure measurement.



STANDARD EXECUTION

DIAPHRAGM	BODY	MOUNTING CONNECTION
AISI 316(L)	AISI 316(L)	top (axial)
FACING	FACING TYPE	
RF	B1	

FLANGED PROCESS CONNECTIONS

ASME B16.5

size	rating	dD
1"	cl. 150 - cl. 2500	32mm
1,5"	cl. 150 - cl. 2500	44mm
2"	cl. 150 - cl. 2500	57mm
3"	cl. 150 - cl. 2500	81mm
4"	cl. 150 - cl. 2500	81mm

API ISO 10423

size	rating	facing	dD
1-13/16"	69 - 138 MPa	6BX - RJF	32mm
2-1/16"	13.8 - 34.5 MPa	6B - RJF	44mm
2-1/16"	69 - 138 MPa	6BX - RJF	44mm
2-9/16"	13.8 - 34.5 MPa	6B - RJF	57mm
2-9/16"	69 - 138 MPa	6Bx - RJF	57mm
3-1/8"	13.8 - 34.5 MPa	6B - RJF	72mm
3-1/8"	39 - 138 MPa	6Bx - RJF	72mm

EN 1092-1

size	rating	dD
DN25	PN10 - PN100	32mm
DN40	PN10 - PN100	44mm
DN50	PN10 - PN100	57mm
DN80	PN10 - PN100	81mm
DN100	PN10 - PN100	81mm

JIS B2220

Size	rating	facing	dD
25 (1")	5K - 20K	RF	32mm
32 (1,25")	5K - 20K	RF	32mm
40 (1,5)	5K - 20K	RF	44mm
50 (2")	5K - 20K	RF	57mm
80 (3")	5K - 20K	RF	81mm
100 (4")	5K - 20K	RF	81mm

Note: JIS RF facing roughness is Ra 3.2-6.3 µm

WETTED PARTS, BODY MATERIALS, AND FACING OPTIONS

diaphragm material	body material
AISI 316(L)	AISI 316(L)
AISI 304(L)	
AISI 321	
AISI 316 UG	
Hastelloy C-276	
Monel 400	Monel 400
Hastelloy C-276	Hastelloy C-276
Duplex 2205	Super Duplex / Duplex
Inconel 600	Inconel 600

facing (ASME B16.5)	
RF	Ra 3.2-6.3 µm
RJF	Ra <1.6 µm
LMF	Ra 3.2-6.3 µm
SMF	Ra <3.2 µm
FF	Ra 3.2-6.3 µm
LTF	Ra <3.2 µm
STF	Ra <3.2 µm
LGF	Ra <3.2 µm
SGF	Ra <3.2 µm
LFF	Ra 3.2-6.3 µm
SFF	Ra <3.2 µm

facing type (EN 1092-1)	
B1	Ra 3.2-12.5 µm
A	Ra 3.2-12.5 µm
B2	Ra 0.8-3.2 µm
C	Ra 0.8-3.2 µm
D	Ra 0.8-3.2 µm
E	Ra 3.2-12.5 µm
F	Ra 3.2-12.5 µm
G	Ra 0.8-3.2 µm
H	Ra 0.8-3.2 µm

COATING AND OTHER OPTIONS

COATINGS

- gold: 25 µm / 40 µm chemical resistance and/or hydrogen permeation protection (facing and/or diaphragm - page 120)
- PTFE / ECTFE for anti stick purpose only
- Tantaline wetted parts
- FEP / PFA
- thermal spray

OTHER OPTIONS

- set of handles welded on side of flange page 113
- heavy duty capillary tube page 113/123
- TR - temperature reducer page 114
- TC - temperature compensator page 114/121
- capillary side mounted (radial)
- LGP – execution for low pressures page 119
- degreasing of wetted parts

II – DATA SHEET

BF – FLUSH DIAPHRAGM, FLANGED TYPE

DRAWING AND DIMENSIONS STANDARD EXECUTIONS

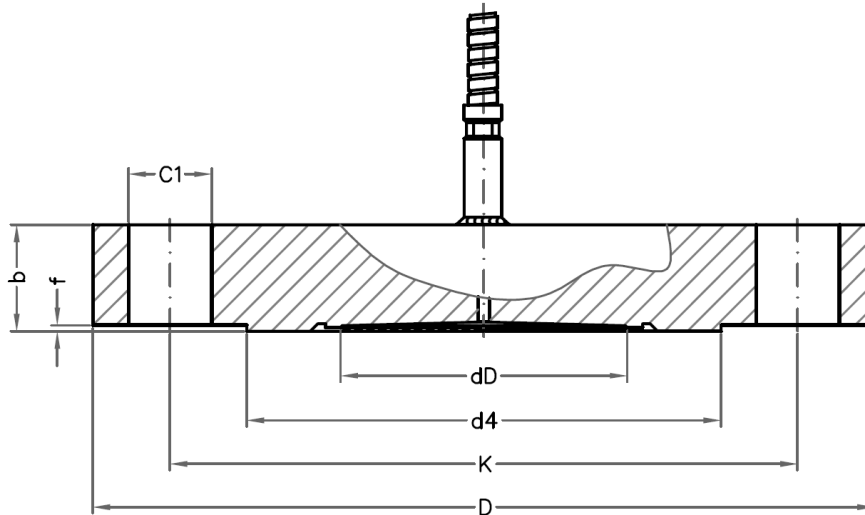

ASME B16.5 - RF FACING

size	rating	facing	dD	b	D	f	d4	K	C1 / pcs	C1 (inch)
1"	cl. 150	RF	32	15	110	2	51	80	16 / 4x	5/8"
1"	cl. 300	RF	32	18	125	2	51	89	19 / 4x	3/4"
1"	cl. 400-600	RF	32	25	125	7	51	89	19 / 4x	3/4"
1"	cl. 900-1500	RF	32	36	150	7	51	102	25 / 4x	1"
1"	cl. 2500	RF	32	42	160	7	51	108	25 / 4x	1"
1,5"	cl. 150	RF	44	18	125	2	73	99	16 / 4x	5/8"
1,5"	cl. 300	RF	44	21	155	2	73	114	22 / 4x	7/8"
1,5"	cl. 400-600	RF	44	29	155	7	73	114	22 / 4x	7/8"
1,5"	cl. 900-1500	RF	44	39	180	7	73	124	29 / 4x	1 1/8"
1,5"	cl. 2500	RF	44	52	205	7	73	146	32 / 4x	1 1/4"
2"	cl. 150	RF	57	20	150	2	92	121	19 / 4x	3/4"
2"	cl. 300	RF	57	23	165	2	92	127	19 / 8x	3/4"
2"	cl. 400-600	RF	57	32	165	7	92	127	19 / 8x	3/4"
2"	cl. 900-1500	RF	57	45	215	7	92	165	25 / 8x	1"
2"	cl. 2500	RF	57	58	235	7	92	171	29 / 8x	1 1/8"
3"	cl. 150	RF	81	24	190	2	127	152	19 / 4x	3/4"
3"	cl. 300	RF	81	29	210	2	127	168	22 / 8x	7/8"
3"	cl. 400-600	RF	81	39	210	7	127	168	22 / 8x	7/8"
3"	cl. 900	RF	81	45	240	7	127	191	25 / 8x	1"
3"	cl. 1500	RF	81	55	265	7	127	203	32 / 8x	1 1/4"
3"	cl. 2500	RF	81	74	305	7	127	229	35 / 8x	1 1/2"
4"	cl. 150	RF	81	24	230	2	157	191	19 / 8x	3/4"
4"	cl. 300	RF	81	32	255	2	157	200	22 / 8x	7/8"
4"	cl. 400	RF	81	42	255	7	157	200	25 / 8x	1"
4"	cl. 600	RF	81	45	275	7	157	216	25 / 8x	1"
4"	cl. 900	RF	81	52	290	7	157	235	32 / 8x	1 1/4"
4"	cl. 1500	RF	81	61	310	7	157	241	35 / 8x	1 1/2"
4"	cl. 2500	RF	81	83	355	7	157	273	42 / 8x	1 3/4"

All dimensions in mm

II – DATA SHEET

BF – FLUSH DIAPHRAGM, FLANGED TYPE

EN 1092-1 - TYPE B1

size	rating	type	dD	b	D	f	d4	K	C1 / pcs
DN25	PN10-40	B1	32	18	115	2	68	85	14 / 4x
DN25	PN63	B1	32	24	140	2	68	100	18 / 4x
DN25	PN100	B1	32	24	140	2	68	100	18 / 4x
DN40	PN10-40	B1	44	18	150	3	88	110	18 / 4x
DN40	PN63	B1	44	26	170	3	88	125	22 / 4x
DN40	PN100	B1	44	26	170	3	88	125	22 / 4x
DN50	PN10-40	B1	57	20	165	3	102	125	18 / 4x
DN50	PN63	B1	57	26	180	3	102	135	22 / 4x
DN50	PN100	B1	57	28	195	3	102	145	26 / 4x
DN80	PN10-40	B1	81	24	200	3	138	160	18 / 8x
DN80	PN63	B1	81	28	215	3	138	170	22 / 8x
DN80	PN100	B1	81	32	230	3	138	180	26 / 8x
DN100	PN10-16	B1	81	20	220	3	158	180	18 / 8x
DN100	PN25-40	B1	81	24	235	3	162	190	22 / 8x
DN100	PN63	B1	81	30	250	3	162	200	26 / 8x
DN100	PN100	B1	81	36	265	3	162	210	30 / 8x

All dimensions in mm

JIS B2220 - RF FACING

size	rating	facing	dD	b	D	f	d4	K	C1 / pcs
25	5K	RF	32	10	95	1	59	75	12 / 4x
25	10K	RF	32	14	125	1	67	90	19 / 4x
25	16K	RF	32	14	125	1	67	90	19 / 4x
25	20K	RF	32	16	125	1	67	90	19 / 4x
32	5K	RF	32	12	115	2	70	90	15 / 4x
32	10K	RF	32	16	135	2	76	100	19 / 4x
32	16K	RF	32	16	135	2	76	100	19 / 4x
32	20K	RF	32	18	135	2	76	100	19 / 4x
40	5K	RF	44	12	120	2	75	95	15 / 4x
40	10K	RF	44	16	140	2	81	105	19 / 4x
40	16K	RF	44	16	140	2	81	105	19 / 4x
40	20K	RF	44	18	140	2	81	105	19 / 4x
50	5K	RF	57	14	130	2	85	105	15 / 4x
50	10K	RF	57	16	155	2	96	120	19 / 4x
50	16K	RF	57	16	155	2	96	120	19 / 8x
50	20K	RF	57	18	155	2	96	120	19 / 8x
80	5K	RF	81	14	180	2	121	145	19 / 4x
80	10K	RF	81	18	185	2	126	150	19 / 8x
80	16K	RF	81	20	200	2	132	160	23 / 8x
80	20K	RF	81	22	200	2	132	160	23 / 8x
100	5K	RF	81	16	200	2	141	163	19 / 8x
100	10K	RF	81	18	210	2	151	175	19 / 8x
100	16K	RF	81	22	225	2	160	185	23 / 8x
100	20K	RF	81	24	225	2	160	185	23 / 8x

All dimensions in mm

II – DATA SHEET

BF – FLUSH DIAPHRAGM, FLANGED TYPE

DRAWING AND DIMENSIONS RJF FACING AND API

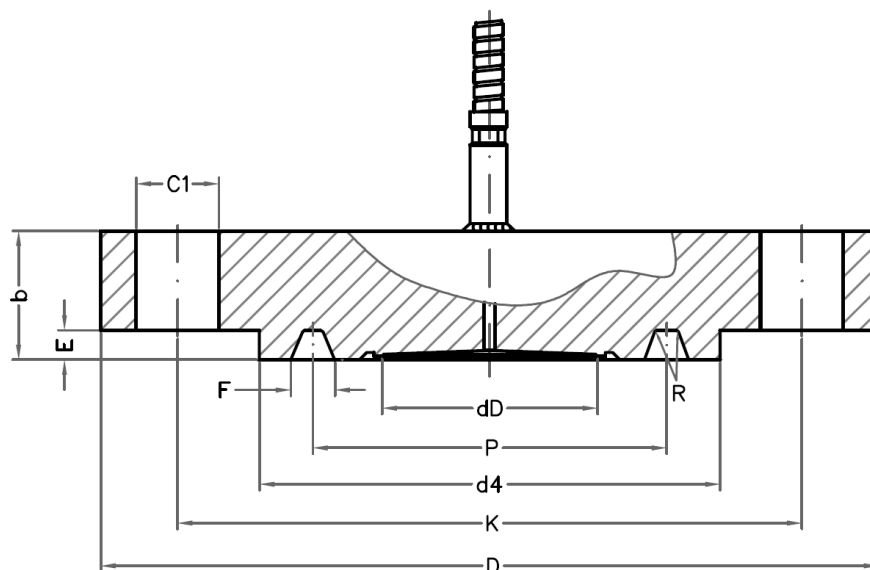

ASME B16.5 - RJF FACING

size	rating	facing	dD	b	D	d4	K	C1 / pcs	C1(inch)	P	F	E	Ring #	R
1"	cl. 150	RJF	32	19	110	64	79	16 / 4x	5/8"	48	9	6	15	0.8
1"	cl. 300	RJF	32	22	125	70	89	19 / 4x	3/4"	51	9	6	16	0.8
1"	cl. 400-600	RJF	32	24	125	70	89	19 / 4x	3/4"	51	9	6	16	0.8
1"	cl. 900-1500	RJF	32	35	150	72	102	25 / 4x	1"	51	9	6	16	0.8
1"	cl. 2500	RJF	32	41	160	83	108	25 / 4x	1"	60	9	6	18	0.8
1.5"	cl. 150	RJF	44	22	125	83	98	16 / 4x	5/8"	65	9	6	19	0.8
1.5"	cl. 300	RJF	44	26	155	91	114	22 / 4x	7/8"	68	9	6	20	0.8
1.5"	cl. 400-600	RJF	44	29	155	91	114	22 / 4x	7/8"	68	9	6	20	0.8
1.5"	cl. 900-1500	RJF	44	38	180	92	124	28 / 4x	1 1/8"	69	9	6	20	0.8
1.5"	cl. 2500	RJF	44	53	205	114	146	32 / 4x	1 1/4"	83	12	8	23	0.8
2"	cl. 150	RJF	57	24	150	102	121	19 / 4x	3/4"	83	9	6	22	0.8
2"	cl. 300	RJF	57	29	165	108	127	19 / 8x	3/4"	83	12	8	23	0.8
2"	cl. 400-600	RJF	57	33	165	108	127	19 / 8x	3/4"	83	12	8	23	0.8
2"	cl. 900-1500	RJF	57	46	215	124	165	25 / 8x	1"	95	12	8	24	0.8
2"	cl. 2500	RJF	57	59	235	133	171	28 / 8x	1 1/8"	102	12	8	26	0.8
3"	cl. 150	RJF	81	29	190	133	152	19 / 4x	3/4"	114	9	6	29	0.8
3"	cl. 300	RJF	81	35	210	146	168	22 / 8x	7/8"	124	12	8	31	0.8
3"	cl. 400-600	RJF	81	40	210	146	168	22 / 8x	7/8"	124	12	8	31	0.8
3"	cl. 900	RJF	81	46	240	156	191	25 / 8x	1"	124	12	8	31	0.8
3"	cl. 1500	RJF	81	56	265	168	203	32 / 8x	1 1/4"	137	12	8	35	0.8
3"	cl. 2500	RJF	81	77	305	168	229	35 / 8x	1 3/8"	127	14	10	32	0.8
4"	cl. 150	RJF	81	29	230	171	191	19 / 8x	3/4"	149	9	6	36	0.8
4"	cl. 300	RJF	81	38	255	175	200	22 / 8x	7/8"	149	12	8	37	0.8
4"	cl. 400	RJF	81	43	255	175	200	25 / 8x	1"	149	12	8	37	0.8
4"	cl. 600	RJF	81	46	275	175	216	25 / 8x	1"	149	12	8	37	0.8
4"	cl. 900	RJF	81	52	290	181	235	32 / 8x	1 1/4"	149	12	8	37	0.8
4"	cl. 1500	RJF	81	62	310	194	241	35 / 8x	1 1/2"	162	12	8	39	0.8
4"	cl. 2500	RJF	81	87	355	203	273	42 / 8x	1 3/4"	157	17	11	38	0.8

All dimensions in mm

II – DATA SHEET

BF – FLUSH DIAPHRAGM, FLANGED TYPE

API 6A ISO 10423 - TYPE 6BX

size		rating	dD	b	D	d4	K	C1/pcs	P	F	E	ring	R
1-13/16"	6BX	69MPa	32mm	42	185	105	146	23 / 8x	66	11	6	BX-151	0.8
1-13/16"	6BX	103,5MPa	32mm	47	210	106	160	26 / 8x	66	11	6	BX-151	0.8
1-13/16"	6BX	138MPa	32mm	47	255	117	203	29 / 8x	66	11	6	BX-151	0.8
2-1/16"	6BX	69MPa	44mm	44	200	111	159	23 / 8x	74	12	6	BX-152	0.8
2-1/16"	6BX	103,5MPa	44mm	53	220	114	175	26 / 8x	74	12	6	BX-152	0.8
2-1/16"	6BX	138MPa	44mm	53	285	132	230	32 / 8x	74	12	6	BX-152	0.8
2-9/16"	6BX	69MPa	57mm	51	230	132	184	23 / 8x	89	14	7	BX-153	0.8
2-9/16"	6BX	103,5MPa	57mm	66	255	133	200	29 / 8x	89	14	7	BX-153	0.8
2-9/16"	6BX	138MPa	57mm	66	325	151	262	35 / 8x	89	14	7	BX-153	0.8
3-1/16"	6BX	69MPa	57mm	64	270	152	216	29 / 8x	104	15	8	BX-154	0.8
3-1/16"	6BX	103,5MPa	57mm	79	290	154	230	32 / 8x	104	15	8	BX-154	0.8
3-1/16"	6BX	138MPa	57mm	79	355	171	287	39 / 8x	104	15	8	BX-154	0.8

All dimensions in mm

API 6A ISO 10423 - TYPE 6B

size		rating	dD	b	D	d4	K	C1/pcs	P	F	E	ring	R
2-1/16"	6B	13,8MPa	44mm	33	165	108	127	20 / 8x	83	12	8	R or RX-23	0.8
2-1/16"	6B	20,7MPa	44mm	46	215	124	165	26 / 8x	95	12	8	R or RX-24	0.8
2-1/16"	6B	34,5MPa	44mm	46	215	124	165	26 / 8x	95	12	8	R or RX-24	0.8
2-9/16"	6B	13,8MPa	57mm	36	190	127	149	23 / 8x	102	12	8	R or RX-26	0.8
2-9/16"	6B	20,7MPa	57mm	38	245	137	190	29 / 8x	108	12	8	R or RX-27	0.8
2-9/16"	6B	34,5MPa	57mm	38	245	137	190	29 / 8x	108	12	8	R or RX-27	0.8
3-1/8"	6B	13,8MPa	72mm	40	210	146	168	23 / 8x	124	12	8	R or RX-31	0.8
3-1/8"	6B	20,7MPa	72mm	46	240	156	191	26 / 8x	124	12	8	R or RX-31	0.8
3-1/8"	6B	34,5MPa	72mm	56	265	168	203	32 / 8x	137	12	8	R or RX-35	0.8

All dimensions in mm

The BRF construction has a seal body that is made of a blind flange and is designed to obtain a diaphragm seal with full wetted parts in exotic materials. With Badotherm unique resistance weld technology, a stainless steel body (non-wetted) has its wetted parts (diaphragm and raised face area) covered by sheet material in the required exotic material. This is more economic than producing the full body in exotic material. BRF is typically used in combination with (differential) pressure transmitters for applications such as level, flow and (absolute) pressure measurement.



STANDARD EXECUTION

WETTED PARTS Hastelloy C-276	BODY AISI 316(L)	MOUNTING CONNECTION top (axial)	GASKET SURFACE FINISH Factory standard
FACING RF	FACING TYPE B1	SOLUTION page 124	

FLANGED PROCESS CONNECTIONS

ASME B16.5

size	rating	dD
1"	cl. 150 - cl. 2500	32mm
1,5"	cl. 150 - cl. 2500	44mm
2"	cl. 150 - cl. 2500	57mm
3"	cl. 150 - cl. 2500	81mm
4"	cl. 150 - cl. 2500	89mm

EN 1092-1

size	rating	dD
DN25	PN10 – PN100	32mm
DN40	PN10 – PN100	44mm
DN50	PN10 – PN100	57mm
DN80	PN10 – PN100	81mm
DN100	PN10 – PN100	89mm

JIS B2220

Size	rating	facing	dD
25 (1")	5K – 20K	RF	32mm
32 (1,25")	5K – 20K	RF	32mm
40 (1,5)	5K – 20K	RF	44mm
50 (2")	5K – 20K	RF	57mm
80 (3")	5K – 20K	RF	81mm
100 (4")	5K – 20K	RF	81mm

WETTED PARTS, BODY MATERIALS, AND FACING OPTIONS

diaphragm material	body material
Monel 400	AISI 316(L)
Hastelloy C-276	
Tantalum	
Nickel 201	
Niobium	
AISI 304(L)	
AISI 321	
Duplex 2205	
Inconel 600	
AISI 316 UG	

facing (ASME B16.5)	facing type (EN 1092-1)
RF	B1
LMF	A
SMF	B2
FF	E

Note: soft gasket to be used with all facings

OTHER OPTIONS

- set of handles welded on side of flange page 113
- heavy duty capillary tube page 113/123
- TR - temperature reducer page 114
- TC - temperature compensator page 114/121
- capillary side mounted (radial)
- LGP – execution for low pressures page 119
- degreasing wetted parts

II – DATA SHEET

BRF – FLUSH DIAPHRAGM, EXOTIC WETTED PARTS, FLANGED TYPE

DRAWING AND DIMENSIONS STANDARD EXECUTIONS

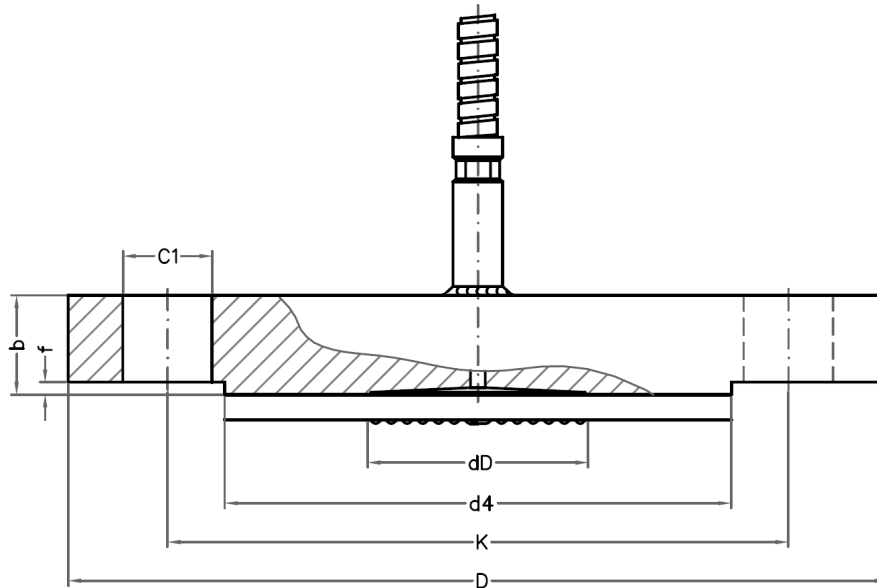

ASME B16.5 - RF FACING

size	rating	facing	dD	b	D	f	d4	K	C1 / pcs	C1 (inch)
1"	cl. 150	RF	32	15	110	2	51	79	16 / 4x	5/8"
1"	cl. 300	RF	32	18	125	2	51	89	19 / 4x	3/4"
1"	cl. 400-600	RF	32	25	125	7	51	89	19 / 4x	3/4"
1"	cl. 900-1500	RF	32	36	150	7	51	102	25 / 4x	1"
1"	cl. 2500	RF	32	42	160	7	51	108	25 / 4x	1"
1,5"	cl. 150	RF	44	18	125	2	73	98	16 / 4x	5/8"
1,5"	cl. 300	RF	44	21	155	2	73	114	22 / 4x	7/8"
1,5"	cl. 400-600	RF	44	29	155	7	73	114	22 / 4x	7/8"
1,5"	cl. 900-1500	RF	44	39	180	7	73	124	29 / 4x	1 1/8"
1,5"	cl. 2500	RF	44	52	205	7	73	146	32 / 4x	1 1/4"
2"	cl. 150	RF	57	20	150	2	92	121	19 / 4x	3/4"
2"	cl. 300	RF	57	23	165	2	92	127	19 / 8x	3/4"
2"	cl. 400-600	RF	57	32	165	7	92	127	19 / 8x	3/4"
2"	cl. 900-1500	RF	57	45	215	7	92	165	25 / 8x	1"
2"	cl. 2500	RF	57	58	235	7	92	171	29 / 8x	1 1/8"
3"	cl. 150	RF	81	24	190	2	127	152	19 / 4x	3/4"
3"	cl. 300	RF	81	29	210	2	127	168	22 / 8x	7/8"
3"	cl. 400-600	RF	81	39	210	7	127	168	22 / 8x	7/8"
3"	cl. 900	RF	81	45	240	7	127	191	25 / 8x	1"
3"	cl. 1500	RF	81	55	265	7	127	203	32 / 8x	1 1/4"
3"	cl. 2500	RF	81	74	305	7	127	229	35 / 8x	1 3/8"
4"	cl. 150	RF	81	24	230	2	157	191	19 / 8x	3/4"
4"	cl. 300	RF	81	32	255	2	157	200	22 / 8x	7/8"
4"	cl. 400	RF	81	42	255	7	157	200	25 / 8x	1"
4"	cl. 600	RF	81	45	275	7	157	216	25 / 8x	1"
4"	cl. 900	RF	81	52	290	7	157	235	32 / 8x	1 1/4"
4"	cl. 1500	RF	81	61	310	7	157	241	35 / 8x	1 3/8"
4"	cl. 2500	RF	81	83	355	7	157	273	42 / 8x	1 3/4"

All dimensions in mm

II – DATA SHEET

BRF – FLUSH DIAPHRAGM, EXOTIC WETTED PARTS, FLANGED TYPE

EN 1092-1 - TYPE B1

size	rating	type	dD	b	D	f	d4	K	C1 / pcs
DN25	PN10-40	B1	32	18	115	2	68	85	14 / 4x
DN25	PN63	B1	32	24	140	2	68	100	18 / 4x
DN25	PN100	B1	32	24	140	2	68	100	18 / 4x
DN40	PN10-40	B1	44	18	150	3	88	110	18 / 4x
DN40	PN63	B1	44	26	170	3	88	125	22 / 4x
DN40	PN100	B1	44	26	170	3	88	125	22 / 4x
DN50	PN10-40	B1	57	20	165	3	102	125	18 / 4x
DN50	PN63	B1	57	26	180	3	102	135	22 / 4x
DN50	PN100	B1	57	28	195	3	102	145	26 / 4x
DN80	PN10-40	B1	81	24	200	3	138	160	18 / 8x
DN80	PN63	B1	81	28	215	3	138	170	22 / 8x
DN80	PN100	B1	81	32	230	3	138	180	26 / 8x
DN100	PN10-16	B1	81	20	220	3	158	180	18 / 8x
DN100	PN25-40	B1	81	24	235	3	162	190	22 / 8x
DN100	PN63	B1	81	30	250	3	162	200	26 / 8x
DN100	PN100	B1	81	36	265	3	162	210	30 / 8x

All dimensions in mm

JIS B2220 - RF FACING

size	rating	facing	dD	b	D	f	d4	K	C1 / pcs
25	5K	RF	32	10	95	1	59	75	12 / 4x
25	10K	RF	32	14	125	1	67	90	19 / 4x
25	16K	RF	32	14	125	1	67	90	19 / 4x
25	20K	RF	32	16	125	1	67	90	19 / 4x
32	5K	RF	32	12	115	2	70	90	15 / 4x
32	10K	RF	32	16	135	2	76	100	19 / 4x
32	16K	RF	32	16	135	2	76	100	19 / 4x
32	20K	RF	32	18	135	2	76	100	19 / 4x
40	5K	RF	44	12	120	2	75	95	15 / 4x
40	10K	RF	44	16	140	2	81	105	19 / 4x
40	16K	RF	44	16	140	2	81	105	19 / 4x
40	20K	RF	44	18	140	2	81	105	19 / 4x
50	5K	RF	57	14	130	2	85	105	15 / 4x
50	10K	RF	57	16	155	2	96	120	19 / 4x
50	16K	RF	57	16	155	2	96	120	19 / 8x
50	20K	RF	57	18	155	2	96	120	19 / 8x
80	5K	RF	81	14	180	2	121	145	19 / 4x
80	10K	RF	81	18	185	2	126	150	19 / 8x
80	16K	RF	81	20	200	2	132	160	23 / 8x
80	20K	RF	81	22	200	2	132	160	23 / 8x
100	5K	RF	81	16	200	2	141	163	19 / 8x
100	10K	RF	81	18	210	2	151	175	19 / 8x
100	16K	RF	81	22	225	2	160	185	23 / 8x
100	20K	RF	81	24	225	2	160	185	23 / 8x

All dimensions in mm

The BC construction has a seal body that is made of bar stock or forged material. The weld of the diaphragm to the seal body is a wetted part and therefore diaphragm materials are mostly chosen the same as the flange material. Its pressure rating is defined by the back-up flange and as such it can be used for all pressure ratings in RF or type B1 facings. An extra feature of BC type seal is that it can be equipped with the so-called LGP module, which allows for Low Gauge Pressure measurement with temperature influences reduced with factor 10.



STANDARD EXECUTION

DIAPHRAGM	BODY	MOUNTING CONNECTION
AISI 316(L)	AISI 316(L)	side (radial)

FACING	FACING TYPE
RF	B1

FLANGED PROCESS CONNECTIONS

ASME B16.5

size	rating	dD
1"	cl. 150 - cl. 2500	32mm
1.5"	cl. 150 - cl. 2500	44mm
2"	cl. 150 - cl. 2500	57mm
3"	cl. 150 - cl. 2500	81mm
4"	cl. 150 - cl. 2500	81mm

EN 1092-1

size	rating	dD
DN25	PN10-400	32mm
DN40	PN10-400	44mm
DN50	PN10-400	57mm
DN80	PN10-400	81mm
DN100	PN10-400	81mm

API ISO 10423

size	rating	facing	dD
1-13/16"	69 - 138 MPa	6BX - RJF	32mm
2-1/16"	13.8 - 34.5 MPa	6B - RJF	44mm
2-1/16"	69 - 138 MPa	6BX - RJF	44mm
2-9/16"	13.8 - 34.5 MPa	6B - RJF	57mm
2-9/16"	69 - 138 MPa	6BX - RJF	57mm
3-1/8"	13.8 - 34.5 MPa	6B - RJF	72mm
3-1/8"	39 - 138 MPa	6BX - RJF	72mm

JIS B2220

Size	rating	facing	dD
25 (1")	5K - 20K	RF	32mm
32 (1.25")	5K - 20K	RF	32mm
40 (1.5)	5K - 20K	RF	44mm
50 (2")	5K - 20K	RF	57mm
80 (3")	5K - 20K	RF	81mm
100 (4")	5K - 20K	RF	81mm

Note: JIS RF facing roughness is Ra 3.2-6.3 µm

WETTED PARTS, BODY MATERIALS, AND FACING OPTIONS

diaphragm material	body material
AISI 316(L)	AISI 316(L)
AISI 304(L)	
AISI 321	
AISI 316 UG	
Hastelloy C-276	
Monel 400	Monel 400
Hastelloy C-276	Hastelloy C-276
Duplex 2205	Super Duplex / Duplex
Inconel 600	Inconel 600
Titanium Gr. 1	Titanium Gr.2

facing (ASME B16.5)	
RF	Ra 3.2-6.3 µm
LMF	Ra 3.2-6.3 µm
SMF	Ra <3.2 µm
LTF	Ra <3.2 µm
LGF	Ra <3.2 µm
STF	Ra <3.2 µm
SGF	Ra <3.2 µm
RJF	Ra <1.6 µm

Facing type (EN 1092-1)	
B1	Ra 0.8-3.2 µm
B2	Ra 0.8-3.2 µm
C	Ra 0.8-3.2 µm
D	Ra 3.2-12.5 µm
E	Ra 3.2-12.5 µm
F	Ra 3.2-12.5 µm

COATING AND OTHER OPTIONS

COATINGS

- gold: 25 µm / 40 µm chemical resistance and/or hydrogen permeation protection (facing and/or diaphragm - page 120)
- PTFE / ECTFE for anti stick purpose only
- Tantaline wetted parts
- FEP / PFA
- thermal spray

OTHER OPTIONS

- TC - temperature compensator
- degreasing wetted parts
- back-up / cover flange

DRAWING AND DIMENSIONS STANDARD EXECUTIONS

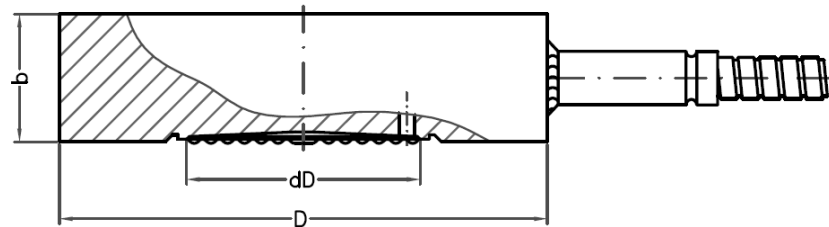

ASME B16.5 - RF FACING

size	rating	facing	dD	b	D
1"	cl. 150 - cl. 2500	RF	32	24	51
1.5"	cl. 150 - cl. 2500	RF	44	24	72
2"	cl. 150 - cl. 2500	RF	57	24	92
3"	cl. 150 - cl. 2500	RF	81	24	127
4"	cl. 150 - cl. 2500	RF	81	24	157

All dimensions in mm

EN 1092-1 - TYPE B1

size	rating	type	dD	b	D
DN25	PN10-400	B1	32	24	68
DN40	PN10-400	B1	44	24	88
DN50	PN10-400	B1	57	24	102
DN80	PN10-400	B1	81	24	138
DN100	PN10-16	B1	81	24	158
DN100	PN25-400	B1	81	24	162

All dimensions in mm

JIS B2220

size	rating	facing	dD	b	D
25	5K	RF	32	24	59
25	10-20K	RF	32	24	67
32	5K	RF	32	24	70
32	10-20K	RF	32	24	76
40	5K	RF	44	24	75
40	10-20K	RF	44	24	81
50	5K	RF	57	24	85
50	10-20K	RF	57	24	96
80	5K	RF	81	24	121
80	10K	RF	81	24	126
80	16-20K	RF	81	24	132
100	5K	RF	81	24	141
100	10K	RF	81	24	151
100	16-20K	RF	81	24	160

All dimensions in mm

DRAWING AND DIMENSIONS RJF FACING

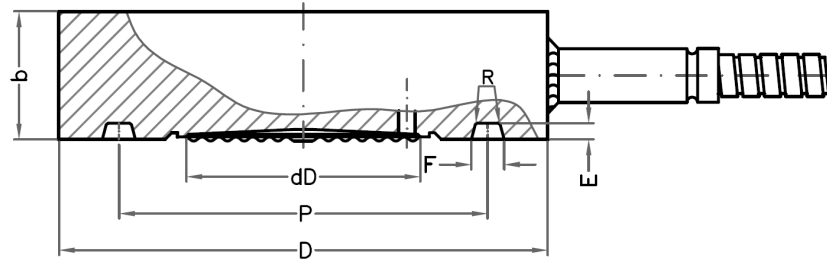

ASME B16.5 - RJF FACING

size	rating	facing	dD	b	D	P	F	E	Ring #	R
1"	cl. 150	RJF	32	28	64	48	9	6	15	0.8
1"	cl. 300	RJF	32	28	70	51	9	6	16	0.8
1"	cl. 400-600	RJF	32	28	70	51	9	6	16	0.8
1"	cl. 900-1500	RJF	32	28	72	51	9	6	16	0.8
1"	cl. 2500	RJF	32	28	83	60	9	6	18	0.8
1,5"	cl. 150	RJF	44	28	83	65	9	6	19	0.8
1,5"	cl. 300	RJF	44	28	91	68	9	6	20	0.8
1,5"	cl. 400-600	RJF	44	28	91	68	9	6	20	0.8
1,5"	cl. 900-1500	RJF	44	28	92	69	9	6	20	0.8
1,5"	cl. 2500	RJF	44	28	114	83	12	8	23	0.8
2"	cl. 150	RJF	57	28	102	83	9	6	22	0.8
2"	cl. 300	RJF	57	28	108	83	12	8	23	0.8
2"	cl. 400-600	RJF	57	28	108	83	12	8	23	0.8
2"	cl. 900-1500	RJF	57	28	124	95	12	8	24	0.8
2"	cl. 2500	RJF	57	28	133	102	12	8	26	0.8
3"	cl. 150	RJF	81	28	133	114	9	6	29	0.8
3"	cl. 300	RJF	81	28	146	124	12	8	31	0.8
3"	cl. 400-600	RJF	81	28	146	124	12	8	31	0.8
3"	cl. 900	RJF	81	28	156	124	12	8	31	0.8
3"	cl. 1500	RJF	81	28	168	137	12	8	35	0.8
3"	cl. 2500	RJF	81	28	168	127	14	10	32	0.8
4"	cl. 150	RJF	81	28	171	149	9	6	36	0.8
4"	cl. 300	RJF	81	28	175	149	12	8	37	0.8
4"	cl. 400	RJF	81	28	175	149	12	8	37	0.8
4"	cl. 600	RJF	81	28	175	149	12	8	37	0.8
4"	cl. 900	RJF	81	28	181	149	12	8	37	0.8
4"	cl. 1500	RJF	81	28	194	162	12	8	39	0.8
4"	cl. 2500	RJF	81	28	203	157	17	11	38	0.8

All dimensions in mm

The BRC construction is designed to obtain a diaphragm seal with full wetted parts in exotic materials. With Badotherm’s unique resistance weld technology, a stainless steel body (non wetted), has its wetted parts (diaphragm and raised face area) covered by sheet material in the required exotic material. This is a more economical solution than producing the full body in exotic material. BRC is typically used in combination with (differential) pressure transmitters for applications such as level, flow and (absolute) pressure measurement. Its pressure rating is defined by the back-up flange mounted by the end-user, as such it can be used for all pressure ratings in RF or type B1 facing.



STANDARD EXECUTION

WETTED PARTS	BODY	GASKET SURFACE FINISH	MOUNTING CONNECTION
Hastelloy C-276	AISI 316(L)	Factory standard	side (radial)
FACING	TYPE	SOLUTION	
RF	type B1	page 124	

FLANGED PROCESS CONNECTIONS

ASME B16.5

size	rating	dD
1"	cl. 150 - cl. 2500	32mm
1,5"	cl. 150 - cl. 2500	44mm
2"	cl. 150 - cl. 2500	57mm
3"	cl. 150 - cl. 2500	81mm
4"	cl. 150 - cl. 2500	89mm

EN 1092-1

size	rating	dD
DN25	PN10 – PN400	32mm
DN40	PN10 – PN400	44mm
DN50	PN10 – PN400	57mm
DN80	PN10 – PN400	81mm
DN100	PN10 – PN400	89mm

JIS B2220

Size	rating	facing	dD
25 (1")	5K – 20K	RF	32mm
32 (1,25")	5K – 20K	RF	32mm
40 (1,5)	5K – 20K	RF	44mm
50 (2")	5K – 20K	RF	57mm
80 (3")	5K – 20K	RF	81mm
100 (4")	5K – 20K	RF	81mm

WETTED PARTS, BODY MATERIALS, AND FACING OPTIONS

diaphragm material	body material
Monel 400	AISI 316(L)
Hastelloy C-276	
Tantalum	
Nickel 201	
Niobium	
AISI 304 (L)	
AISI 321	
AISI 316 UG	
Duplex 2205	
Inconel 600	

facing (ASME B16.5)	facing type (EN 1092-1)
RF	B1
LMF	B2
SMF	F

Note: soft gasket to be used with all facings

OPTIONS

- TC - temperature compensator page 114/121
- back-up / cover flange

DRAWING AND DIMENSIONS STANDARD EXECUTIONS

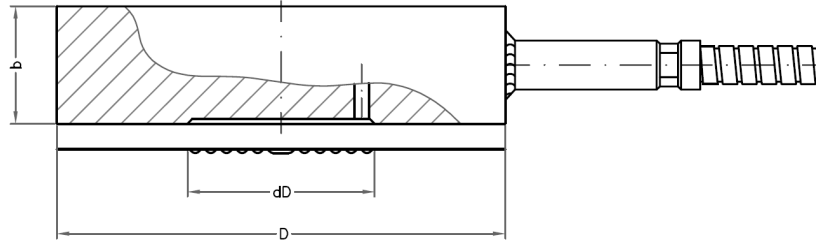

ASME B16.5 - RF FACING

size	rating	facing	dD	b	D
1"	cl. 150 - cl. 2500	RF	32	24	51
1.5"	cl. 150 - cl. 2500	RF	44	24	72
2"	cl. 150 - cl. 2500	RF	57	24	92
3"	cl. 150 - cl. 2500	RF	81	24	127
4"	cl. 150 - cl. 2500	RF	81	24	157

All dimensions in mm

EN 1092-1 - TYPE B1

size	rating	type	dD	b	D
DN25	PN10-400	B1	32	24	68
DN40	PN10-400	B1	44	24	88
DN50	PN10-400	B1	57	24	102
DN80	PN10-400	B1	81	24	138
DN100	PN10-16	B1	81	24	158
DN100	PN25-400	B1	81	24	162

All dimensions in mm

JIS B2220

size	rating	facing	dD	b	D
25	5K	RF	32	24	59
25	10-20K	RF	32	24	67
32	5K	RF	32	24	70
32	10-20K	RF	32	24	76
40	5K	RF	44	24	75
40	10-20K	RF	44	24	81
50	5K	RF	57	24	85
50	10-20K	RF	57	24	96
80	5K	RF	81	24	121
80	10K	RF	81	24	126
80	16-20K	RF	81	24	132
100	5K	RF	81	24	141
100	10K	RF	81	24	151
100	16-20K	RF	81	24	160

All dimensions in mm

EXT is typically used in combination with (differential) pressure transmitters for level, flow and (absolute) pressure measurement, in those applications where the diaphragm need to be flush with the vessel wall or where insulation layers need to be passed.



STANDARD EXECUTION

DIAPHRAGM	BODY	MOUNTING CONNECTION
AISI 316(L)	AISI 316(L)	top (axial)
FACING	TYPE	STANDARD LENGTH
RF	type B1	50/100/150/200 mm

FLANGED PROCESS CONNECTIONS

ASME B16.5

size	rating	dD
1,5"	cl. 150 - cl. 2500	32mm
2"	cl. 150 - cl. 2500	44mm
3"	cl. 150 - cl. 2500	72mm
4"	cl. 150 - cl. 2500	81mm

EN 1092-1

size	rating	dD
DN40	PN10-100	32mm
DN50	PN10-100	44mm
DN80	PN10-100	72mm
DN100	PN10-100	81mm

JIS B2220

Size	rating	facing	dD
40 (1,5)	5K – 20K	RF	44mm
50 (2")	5K – 20K	RF	57mm
80 (3")	5K – 20K	RF	81mm
100 (4")	5K – 20K	RF	81mm

WETTED PARTS, BODY MATERIALS, AND FACING OPTIONS

diaphragm material	body material
AISI 316(L)	AISI 316(L)
AISI 304(L)	
AISI 321	
AISI 316 UG	
Hastelloy C-276	
Monel 400	Monel 400
Hastelloy C-276	Hastelloy C-276
Duplex 2205	Super Duplex / Duplex
Inconel 600	Inconel 600

facing (ASME B16.5)	
RF	Ra 3.2-6.3 µm
RJF	Ra <1.6 µm
LMF	Ra 3.2-6.3 µm
SMF	Ra <3.2 µm
LTF	Ra <3.2 µm
STF	Ra <3.2 µm
LGF	Ra <3.2 µm
SGF	Ra <3.2 µm

facing type (EN 1092-1)	
B1	Ra 3.2-12.5 µm
A	Ra 3.2-12.5 µm
B2	Ra 0.8-3.2 µm
C	Ra 0.8-3.2 µm
D	Ra 0.8-3.2 µm
E	Ra 3.2-12.5 µm
F	Ra 3.2-12.5 µm

COATING AND OTHER OPTIONS

COATINGS

- gold: 25 µm / 40 µm hydrogen permeation protection (diaphragm only - page 120)
- PTFE / ECTFE for anti stick purpose only
- Tantaline wetted parts
- FEP / PFA
- thermal spray

OTHER OPTIONS

- set of handles welded on side of flange page 113
- heavy duty capillary tube page 113/123
- TR - temperature reducer page 114
- TC - temperature compensator page 114/121
- capillary side mounted (radial)
- PTFE sleeve / lining
- customized length and diameter
- degreased wetted parts
- polished extension
- jacket holes
- tapered extension

DRAWING AND DIMENSIONS STANDARD EXECUTIONS

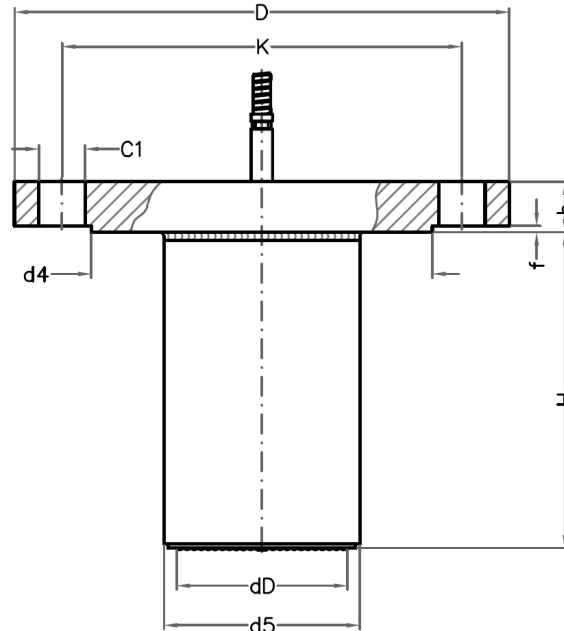

ASME B16.5 - RF FACING

size	rating	facing	dD	b	D	f	d4	d5	H	K	C1 / pcs	C1 (inch)
2"	cl. 150	RF	44	20	150	2	92	48	various	121	19 / 4x	3/4"
2"	cl. 300	RF	44	23	165	2	92	48	various	127	19 / 8x	3/4"
2"	cl. 400-600	RF	44	32	165	7	92	48	various	127	19 / 8x	3/4"
2"	cl. 900-1500	RF	44	45	215	7	92	48	various	165	25 / 8x	1"
2"	cl. 2500	RF	44	58	235	7	92	48	various	171	29 / 8x	1 1/8"
3"	cl. 150	RF	72	24	190	2	127	76	various	152	19 / 4x	3/4"
3"	cl. 300	RF	72	29	210	2	127	76	various	168	22 / 8x	7/8"
3"	cl. 400-600	RF	72	39	210	7	127	76	various	168	22 / 8x	7/8"
3"	cl. 900	RF	72	45	240	7	127	76	various	191	25 / 8x	1"
3"	cl. 1500	RF	72	55	265	7	127	76	various	203	32 / 8x	1 1/4"
3"	cl. 2500	RF	72	74	305	7	127	76	various	229	35 / 8x	1 3/8"
4"	cl. 150	RF	81	24	230	2	157	93	various	191	19 / 8x	3/4"
4"	cl. 300	RF	81	32	255	2	157	93	various	200	22 / 8x	7/8"
4"	cl. 400	RF	81	42	255	7	157	93	various	200	25 / 8x	1"
4"	cl. 600	RF	81	45	275	7	157	93	various	216	25 / 8x	1"
4"	cl. 900	RF	81	52	290	7	157	93	various	235	32 / 8x	1 1/4"
4"	cl. 1500	RF	81	61	310	7	157	93	various	241	35 / 8x	1 3/8"
4"	cl. 2500	RF	81	83	355	7	157	93	various	273	42 / 8x	1 5/8"

All dimensions in mm

EN 1092-1 - TYPE B1

size	rating	type	dD	b	D	f	d4	d5	H	K	C1 / pcs
DN50	PN10-40	B1	44	20	165	3	102	48	various	125	18 / 4x
DN50	PN63	B1	44	26	180	3	102	48	various	135	22 / 4x
DN50	PN100	B1	44	28	195	3	102	48	various	145	26 / 4x
DN80	PN10-40	B1	72	24	200	3	138	76	various	160	18 / 8x
DN80	PN63	B1	72	28	215	3	138	76	various	170	22 / 8x
DN80	PN100	B1	72	32	230	3	138	76	various	180	26 / 8x
DN100	PN10-16	B1	81	20	220	3	158	93	various	180	18 / 8x
DN100	PN25-40	B1	81	24	235	3	162	93	various	190	22 / 8x
DN100	PN63	B1	81	30	250	3	162	93	various	200	26 / 8x
DN100	PN100	B1	81	36	265	3	162	93	various	210	30 / 8x

All dimensions in mm

II – DATA SHEET

EXT – EXTENDED DIAPHRAGM, FLANGED TYPE

JIS B2220 - RF FACING

size	rating	facing	dD	b	D	f	d4	d5	H	K	C1 / pcs
50	5K	RF	44	14	130	2	85	48	various	105	15 / 4x
50	10K	RF	44	16	155	2	96	48	various	120	19 / 4x
50	16K	RF	44	16	155	2	96	48	various	120	19 / 8x
50	20K	RF	44	18	155	2	96	48	various	120	19 / 8x
80	5K	RF	72	14	180	2	121	76	various	145	19 / 4x
80	10K	RF	72	18	185	2	126	76	various	150	19 / 8x
80	16K	RF	72	20	200	2	132	76	various	160	23 / 8x
80	20K	RF	72	22	200	2	132	76	various	160	23 / 8x
100	5K	RF	81	16	200	2	141	93	various	163	19 / 8x
100	10K	RF	81	18	210	2	151	93	various	175	19 / 8x
100	16K	RF	81	22	225	2	160	93	various	185	23 / 8x
100	20K	RF	81	24	225	2	160	93	various	185	23 / 8x

All dimensions in mm

The USF construction is designed for those applications where the existing process connection is too small to use a flush diaphragm seal. The USF consists of an upper and lower housing. The lower housing creates the transition from the diaphragm size to the actual small process connection. USF is typically used in combination with (differential) pressure transmitters for applications such as level, flow and (absolute) pressure measurement; also the USF is often combined with pressure gauges.



STANDARD EXECUTION

DIAPHRAGM	BODY	MOUNTING CONNECTION	
AISI 316(L)	AISI 316(L)	top (axial)	
FACING	FACING TYPE	GASKET	BOLTS
RF	B1	Virgin PTFE	3/8" UNF – A2-70

FLANGED PROCESS CONNECTIONS

ASME B16.5

size	rating	dD
1/2"	cl. 150 – cl. 1500	51mm
1"	cl. 150 – cl. 1500	51mm
1.5"	cl. 150 – cl. 1500	51mm
2"	cl. 150 – cl. 1500	51mm
3"	cl. 150 – cl. 1500	51mm

EN 1092-1

size	rating	dD
DN15	PN10 – PN100	51mm
DN25	PN10 – PN100	51mm
DN40	PN10 – PN100	51mm
DN50	PN10 – PN100	51mm
DN80	PN10 – PN100	51mm

UPPER AND LOWER PART ASSEMBLY

BOLTING

thread	material	mwp	pcs	rating (ASME)	rating (EN)
3/8" UNF	A2-70	125 bar	4	cl. 150 - cl. 600	PN10 – PN100
3/8" UNF	A2-70	250 bar	8	cl. 900 - cl. 1500	PN160 – PN250
3/8" UNF	8.8	150 bar	4	cl. 150 - cl. 600	PN10 – PN100
3/8" UNF	8.8	300 bar	8	cl. 900 - cl. 1500	PN160 – PN250

GASKET

material	operating temperature
Virgin PTFE	-200 / +260°C
Garfite N	-73 / +343°C
Camprofile ¹	-200 / + 500°C

Note: mwp (maximum working pressure) at 20 °C with AISI 316(L) body material

¹ for steam applications

WETTED PARTS, BODY MATERIALS, AND FACING OPTIONS

diaphragm mat.	body material	lowerpart material
AISI 316(L)	AISI 316(L)	AISI 316(L)
AISI 304(L)		
AISI 321		
AISI 316 UG		
Hastelloy C-276		
Hastelloy C-276	AISI 316(L)	Hastelloy C-276
Monel 400	AISI 316(L)	Monel 400
Tantalum	AISI 316(L)	Tantalum ¹
Nickel 201	AISI 316(L)	Nickel 201
Duplex 2205	AISI 316(L)	Duplex
Inconel 600	AISI 316(L)	Inconel 600
Titanium Gr.1	Titanium Gr.2	Titanium Gr.2

¹Note: material AISI 316(L) with Tantaline treatment

facing (ASME B16.5)	
RF	Ra 3.2-6.3 µm
RJF	Ra <1.6 µm
LMF	Ra 3.2-6.3 µm
SMF	Ra <3.2 µm
FF	Ra 3.2-6.3 µm
LTF	Ra <3.2 µm
STF	Ra <3.2 µm
LGF	Ra <3.2 µm
SGF	Ra <3.2 µm
LFF	Ra 3.2-6.3 µm
SFF	Ra <3.2 µm

facing type (EN 1092-1)	
B1	Ra 3.2-12.5 µm
A	Ra 3.2-12.5 µm
B2	Ra 0.8-3.2 µm
C	Ra 0.8-3.2 µm
D	Ra 0.8-3.2 µm
E	Ra 3.2-12.5 µm
F	Ra 3.2-12.5 µm
G	Ra 0.8-3.2 µm
H	Ra 0.8-3.2 µm

COATING AND OTHER OPTIONS

COATINGS

- gold: 25 µm / 40 µm chemical resistance and/or hydrogen permeation protection (facing and/or diaphragm – page 120)
- PTFE / ECTFE for anti stick purpose only (upper part)
- FEP / PFA (upper part)
- Tantaline wetted parts
- PTFE lining (lower part)

OTHER OPTIONS

- heavy duty capillary tube page 113/123
- TR - temperature reducer page 114
- PTFE sheet for anti-stick purpose only (no vacuum)
- flushing ports in lower part (not in combination with lining)
- degreasing of wetted parts

DRAWING AND DIMENSIONS STANDARD EXECUTIONS

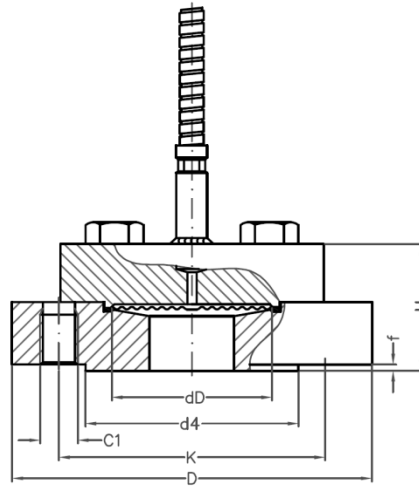

ASME B16.5 - RF FACING

size	rating	facing	dD	D	f	d4	K	H	C1 / pcs
1/2"	cl. 150	RF	51	89	2	35	61	50	1/2" 13 UNC / 4x
1/2"	cl. 300	RF	51	95	2	35	67	52	1/2" 13 UNC / 4x
1/2"	cl. 400-600	RF	51	95	7	35	67	57	1/2" 13 UNC / 4x
1/2"	cl. 900-1500	RF	51	120	7	35	83	56	3/4" 10 UNC / 4x
1"	cl. 150	RF	51	110	2	51	79	42	1/2" 13 UNC / 4x
1"	cl. 300	RF	51	125	2	51	89	47	5/8" 11 UNC / 4x
1"	cl. 400-600	RF	51	125	7	51	89	52	5/8" 11 UNC / 4x
1"	cl. 900-1500	RF	51	150	7	51	102	60	7/8" 9 UNC / 4x
1,5"	cl. 150	RF	51	125	2	73	98	42	1/2" 13 UNC / 4x
1,5"	cl. 300	RF	51	155	2	73	114	53	3/4" 10 UNC / 4x
1,5"	cl. 400-600	RF	51	155	7	73	114	56	3/4" 10 UNC / 4x
1,5"	cl. 900-1500	RF	51	180	7	73	124	56	1 1/8" 7 UNC / 4x
2"	cl. 150	RF	51	150	2	92	121	39	19mm / 4x
2"	cl. 300	RF	51	165	2	92	127	42	19mm / 8x
2"	cl. 400-600	RF	51	165	7	92	127	52	19mm / 8x
2"	cl. 900-1500	RF	51	215	7	92	165	58	25mm / 8x
3"	cl. 150	RF	51	190	2	127	152	46	19mm / 4x
3"	cl. 300	RF	51	210	2	127	168	51	22mm / 8x
3"	cl. 400-600	RF	51	210	7	127	168	58	22mm / 8x
3"	cl. 900	RF	51	240	7	127	191	65	25mm / 8x
3"	cl. 1500	RF	51	265	7	127	203	75	32mm / 8x

All dimensions in mm

EN 1092-1 - TYPE B1

size	rating	type	dD	D	f	d4	K	H	C1 / pcs
DN15	PN10-40	B1	51	95	2	45	65	52	M12 / 4x
DN15	PN63	B1	51	105	2	45	75	49	M12 / 4x
DN15	PN100	B1	51	105	2	45	75	49	M12 / 4x
DN25	PN10-40	B1	51	115	2	68	85	44	M12 / 4x
DN25	PN63	B1	51	140	2	68	100	55	M16 / 4x
DN25	PN100	B1	51	140	2	68	100	55	M16 / 4x
DN40	PN10-40	B1	51	150	3	88	110	44	M16 / 4x
DN40	PN63	B1	51	170	3	88	125	46	M20 / 4x
DN40	PN100	B1	51	170	3	88	125	46	M20 / 4x
DN50	PN10-40	B1	51	165	3	102	125	50	M16 / 4x
DN50	PN63	B1	51	180	3	102	135	50	M20 / 4x
DN50	PN100	B1	51	195	3	102	145	48	M24 / 4x
DN80	PN10-40	B1	51	200	3	138	160	44	18mm / 4x
DN80	PN63	B1	51	215	3	138	170	50	22mm / 8x
DN80	PN100	B1	51	230	3	138	180	56	26mm / 8x

All dimensions in mm

The USLF construction is designed for those applications where the existing process connection is too small to use a flush diaphragm seal. The USLF consists of an upper and lower housing, the upper is the actual seal part with a diaphragm size that allows for measurement of low ranges (10 mbar 2 seals attached (dP); 80 mbar single seal attached). The lower housing creates the transition from the diaphragm size to the smaller process connection. USLF is typically used in combination with (differential) pressure transmitters for applications such as level, flow and (absolute) pressure measurement.



STANDARD EXECUTION

DIAPHRAGM	BODY	MOUNTING CONNECTION	
AISI 316(L)	AISI 316(L)	top (axial)	
FACING	FACING TYPE	GASKET	BOLTS
RF	B1	Virgin PTFE	M10 – A2-70

FLANGED PROCESS CONNECTIONS

ASME B16.5

size	rating	dD
1/2"	cl. 150 – cl. 600	81mm
1"	cl. 150 – cl. 600	81mm
1.5"	cl. 150 – cl. 600	81mm
2"	cl. 150 – cl. 600	81mm
3"	cl. 150 – cl. 600	81mm

EN 1092-1

size	rating	dD
DN15	PN10 – PN100	81mm
DN25	PN10 – PN100	81mm
DN40	PN10 – PN100	81mm
DN50	PN10 – PN100	81mm
DN80	PN10 – PN100	81mm

UPPER AND LOWER PART ASSEMBLY

BOLTING

thread	material	mwp	pcs	rating (ASME)	rating (EN)
M10	A2-70	100 bar	8	cl. 150 – cl. 600	PN10 – PN100
M10	8.8	120 bar	8	cl. 150 – cl. 600	PN10 – PN100

Note: mwp (maximum working pressure) at 20 °C with AISI 316(L) body material

GASKET

material	operating temperature
Virgin PTFE	-200 / +260°C
Garfite N	-73 / +343°C
Camprofile ¹	-200 /+ 500°C

¹ for steam applications

WETTED PARTS, BODY MATERIALS, AND FACING OPTIONS

diaphragm mat.	body material	lowerpart material
AISI 316(L)	AISI 316(L)	AISI 316(L)
AISI 304(L)		
AISI 321		
AISI 316 UG		
Hastelloy C-276		
Hastelloy C-276	AISI 316(L)	Hastelloy C-276
Monel 400	AISI 316(L)	Monel 400
Tantalum	AISI 316(L)	Tantalum*
Nickel 201	AISI 316(L)	Nickel 201
Duplex 2205	AISI 316(L)	Duplex
Inconel 600	AISI 316(L)	Inconel 600
Titanium Gr.1	Titanium Gr.2	Titanium Gr.2

*Note: material AISI 316(L) with Tantaline treatment

facing (ASME B16.5)

RF	Ra 3.2-6.3 µm
RJF	Ra <1.6 µm
LMF	Ra 3.2-6.3 µm
SMF	Ra <3.2 µm
FF	Ra 3.2-6.3 µm
LTF	Ra <3.2 µm
STF	Ra <3.2 µm
LGF	Ra <3.2 µm
SGF	Ra <3.2 µm
LFF	Ra 3.2-6.3 µm
SFF	Ra <3.2 µm

facing type (EN 1092-1)

B1	Ra 3.2-12.5 µm
A	Ra 3.2-12.5 µm
B2	Ra 0.8-3.2 µm
C	Ra 0.8-3.2 µm
D	Ra 0.8-3.2 µm
E	Ra 3.2-12.5 µm
F	Ra 3.2-12.5 µm
G	Ra 0.8-3.2 µm
H	Ra 0.8-3.2 µm

COATING AND OTHER OPTIONS

COATINGS

- gold: 25 µm / 40 µm hydrogen permeation protection (diaphragm – page 120)
- PTFE / ECTFE for anti stick purpose only (upper part)
- FEP / PFA (upper part)
- Tantaline wetted parts
- PTFE lining (lower part)

OTHER OPTIONS

- heavy duty capillary tube page 113/123
- TR - temperature reducer page 114
- TC - temperature compensator page 114/121
- PTFE sheet for anti-stick purpose only (no vacuum)
- flushing ports in lower part (not in combination with lining)
- LGP – execution for low pressures page 119
- degreasing of wetted parts

DRAWING AND DIMENSIONS STANDARD EXECUTIONS

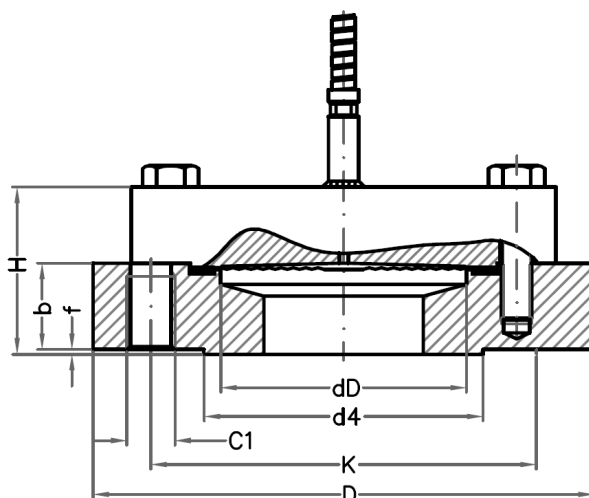

ASME B16.5 - RF FACING

size	rating	facing	dD	D	f	d4	K	b	H	C1 / pcs
1/2"	cl. 150	RF	81	140	2	35	61	40	67	1/2" 13 UNC / 4x
1/2"	cl. 300	RF	81	140	2	35	67	40	67	1/2" 13 UNC / 4x
1/2"	cl. 400-600	RF	81	140	7	35	67	40	67	1/2" 13 UNC / 4x
1"	cl. 150	RF	81	140	2	51	79	38	64	1/2" 13 UNC / 4x
1"	cl. 300	RF	81	140	2	51	89	38	64	5/8" 11 UNC / 4x
1"	cl. 400-600	RF	81	140	7	51	89	45	71	5/8" 11 UNC / 4x
1,5"	cl. 150	RF	81	140	2	73	99	38	64	1/2" 13 UNC / 4x
1,5"	cl. 300	RF	81	155	2	73	114	40	67	3/4" 10 UNC / 4x
1,5"	cl. 400-600	RF	81	155	7	73	114	45	71	3/4" 10 UNC / 4x
2"	cl. 150	RF	81	152	2	92	121	30	57	5/8" 11 UNC / 4x
2"	cl. 300	RF	81	165	2	92	127	30	57	5/8" 11 UNC / 8x
2"	cl. 400-600	RF	81	165	7	92	127	35	62	5/8" 11 UNC / 8x
3"	cl. 150	RF	81	191	2	127	152	30	57	5/8" 11 UNC / 4x
3"	cl. 300	RF	81	210	2	127	168	30	57	3/4" 10 UNC / 8x
3"	cl. 400-600	RF	81	210	7	127	168	39	66	3/4" 10 UNC / 8x

All dimensions in mm

EN 1092-1 - TYPE B1

size	rating	type	dD	D	f	d4	K	b	H	C1 / pcs
DN15	PN10-40	B1	81	140	2	45	65	40	52	M12 / 4x
DN15	PN63	B1	81	140	2	45	75	40	49	M12 / 4x
DN15	PN100	B1	81	140	2	45	75	40	49	M12 / 4x
DN25	PN10-40	B1	81	140	2	68	85	40	44	M12 / 4x
DN25	PN63	B1	81	140	2	68	100	45	55	M16 / 4x
DN25	PN100	B1	81	140	2	68	100	45	55	M16 / 4x
DN40	PN10-40	B1	81	150	3	88	110	40	44	M16 / 4x
DN40	PN63	B1	81	170	3	88	125	40	46	M20 / 4x
DN40	PN100	B1	81	170	3	88	125	40	46	M20 / 4x
DN50	PN10-40	B1	81	165	3	102	125	30	50	M16 / 4x
DN50	PN63	B1	81	180	3	102	135	35	50	M20 / 4x
DN50	PN100	B1	81	195	3	102	145	40	48	M24 / 4x
DN80	PN10-40	B1	81	200	3	138	160	30	44	18mm / 4x
DN80	PN63	B1	81	215	3	138	170	35	50	22mm / 8x
DN80	PN100	B1	81	230	3	138	180	40	56	26mm / 8x

All dimensions in mm

The FSO-BF construction has a seal body that is made of bar stock or forged material. The weld between the seal body and the diaphragm is a wetted part and therefore diaphragm materials are mostly chosen the same as the body material. The FSO-BF is recommended when special body or flange material grades are required. FSO-BF is typically used in combination with (differential) pressure transmitters for applications such as level, flow and (absolute) pressure measurement.



STANDARD EXECUTION

DIAPHRAGM	BODY	MOUNTING CONNECTION
AISI 316(L)	AISI 316(L)	top (axial)
FACING	FACING TYPE	
RF	B1	

FLANGED PROCESS CONNECTIONS

ASME B16.5

size	rating	dD
1"	cl. 150 - cl. 2500	32mm
1,5"	cl. 150 - cl. 2500	44mm
2"	cl. 150 - cl. 2500	57mm
3"	cl. 150 - cl. 2500	81mm
4"	cl. 150 - cl. 2500	81mm

EN 1092-1

size	rating	dD
DN25	PN10 - PN100	32mm
DN40	PN10 - PN100	44mm
DN50	PN10 - PN100	57mm
DN80	PN10 - PN100	81mm
DN100	PN10 - PN100	81mm

API 6A ISO 10423

size	rating	facing	dD
1-13/16"	69 - 138 MPa	6BX - RJF	32mm
2-1/16"	13.8 – 34.5 MPa	6B - RJF	44mm
2-1/16"	69 – 138 MPa	6BX - RJF	44mm
2-9/16"	13.8 – 34.5 MPa	6B - RJF	57mm
2-9/16"	69 – 138 MPa	6Bx - RJF	57mm
3-1/8"	13.8 – 34.5 MPa	6B - RJF	72mm
3-1/8"	39 – 138 MPa	6Bx - RJF	72mm

JIS B2220

Size	rating	facing	dD
25 (1")	5K – 20K	RF	32mm
32 (1,25")	5K – 20K	RF	32mm
40 (1,5)	5K – 20K	RF	44mm
50 (2")	5K – 20K	RF	57mm
80 (3")	5K – 20K	RF	81mm
100 (4")	5K – 20K	RF	81mm

Note: JIS RF facing roughness is Ra 3.2-6.3 µm

WETTED PARTS, BODY MATERIALS, AND FACING OPTIONS

diaphragm material	body material
AISI 316(L)	AISI 316(L)
AISI 304(L)	
AISI 321	
AISI 316 UG	
Hastelloy C-276	
Monel 400	Monel 400
Hastelloy C-276	Hastelloy C-276
Duplex 2205	Super Duplex / Duplex
Inconel 600	Inconel 600
Titanium Gr. 1	Titanium Gr. 2
Nickel 201	Nickel 201

facing (ASME B16.5)	
RF	Ra 3.2-6.3 µm
RJF	Ra <1.6 µm
LMF	Ra 3.2-6.3 µm
SMF	Ra <3.2 µm
LTF	Ra <3.2 µm
STF	Ra <3.2 µm
LGF	Ra <3.2 µm
SGF	Ra <3.2 µm
LFF	Ra 3.2-6.3 µm
SFF	Ra <3.2 µm

facing type (EN 1092-1)	
B1	Ra 3.2-12.5 µm
B2	Ra 0.8-3.2 µm
C	Ra 0.8-3.2 µm
D	Ra 0.8-3.2 µm
E	Ra 3.2-12.5 µm
F	Ra 3.2-12.5 µm
G	Ra 0.8-3.2 µm
H	Ra 0.8-3.2 µm

COATING AND OTHER OPTIONS

COATINGS

- gold: 25 µm / 40 µm chemical resistance and/or hydrogen permeation protection (facing and/or diaphragm – page 120)
- PTFE / ECTFE for anti stick purpose only
- Tantaline wetted parts
- FEP / PFA
- thermal spray

OTHER OPTIONS

- set of handles welded on side of flange page 113
- heavy duty capillary tube page 113/123
- TR - temperature reducer page 114
- TC - temperature compensator page 114/121
- cover flange in exotic material
- degreasing of wetted parts

DRAWING AND DIMENSIONS STANDARD EXECUTIONS

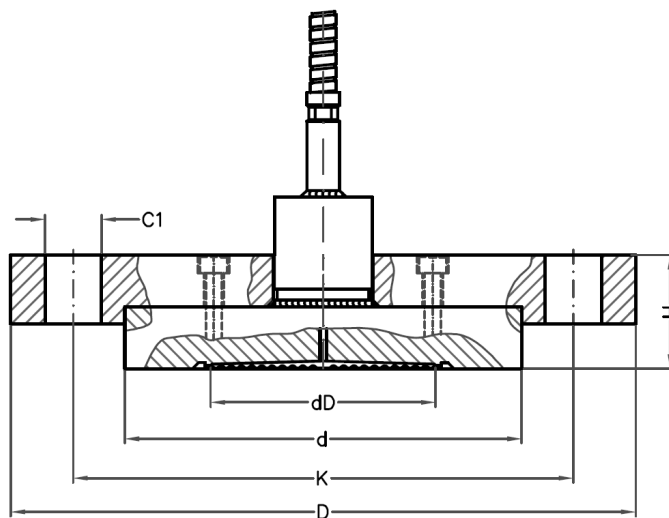

ASME B16.5 - RF FACING

size	rating	facing	dD	H	D	d	K	C1 / pcs	C1 (inch)
1"	cl. 150	RF	32	27	110	51	80	16 / 4x	5/8"
1"	cl. 300	RF	32	30	125	51	89	19 / 4x	3/4"
1"	cl. 400-600	RF	32	32	125	51	89	19 / 4x	3/4"
1"	cl. 900-1500	RF	32	43	150	51	102	25 / 4x	1"
1"	cl. 2500	RF	32	49	160	51	108	25 / 4x	1"
1,5"	cl. 150	RF	44	30	125	73	99	16 / 4x	5/8"
1,5"	cl. 300	RF	44	33	155	73	114	22 / 4x	7/8"
1,5"	cl. 400-600	RF	44	36	155	73	114	22 / 4x	7/8"
1,5"	cl. 900-1500	RF	44	46	180	73	124	29 / 4x	1 1/8"
1,5"	cl. 2500	RF	44	59	205	73	146	32 / 4x	1 1/4"
2"	cl. 150	RF	57	32	150	92	121	19 / 4x	3/4"
2"	cl. 300	RF	57	35	165	92	127	19 / 8x	3/4"
2"	cl. 400-600	RF	57	44	165	92	127	19 / 8x	3/4"
2"	cl. 900-1500	RF	57	57	215	92	165	25 / 8x	1"
2"	cl. 2500	RF	57	70	235	92	171	29 / 8x	1 1/8"
3"	cl. 150	RF	81	36	190	127	152	19 / 4x	3/4"
3"	cl. 300	RF	81	41	210	127	168	22 / 8x	7/8"
3"	cl. 400-600	RF	81	46	210	127	168	22 / 8x	7/8"
3"	cl. 900	RF	81	52	240	127	191	25 / 8x	1"
3"	cl. 1500	RF	81	67	265	127	203	32 / 8x	1 1/4"
3"	cl. 2500	RF	81	86	305	127	229	35 / 8x	1 1/2"
4"	cl. 150	RF	81	36	230	157	191	19 / 8x	3/4"
4"	cl. 300	RF	81	44	255	157	200	22 / 8x	7/8"
4"	cl. 400	RF	81	49	255	157	200	25 / 8x	1"
4"	cl. 600	RF	81	52	275	157	216	25 / 8x	1"
4"	cl. 900	RF	81	59	290	157	235	32 / 8x	1 1/4"
4"	cl. 1500	RF	81	68	310	157	241	35 / 8x	1 1/2"
4"	cl. 2500	RF	81	90	355	157	273	42 / 8x	1 1/2"

All dimensions in mm

II – DATA SHEET

FSO-BF – FLUSH DIAPHRAGM, FLANGED TYPE

EN 1092-1 - TYPE B1

size	rating	type	dD	H	D	d	K	C1 / pcs
DN25	PN10-40	B1	32	30	115	68	85	14 / 4x
DN25	PN63	B1	32	36	140	68	100	18 / 4x
DN25	PN100	B1	32	36	140	68	100	18 / 4x
DN40	PN10-40	B1	44	30	150	88	110	18 / 4x
DN40	PN63	B1	44	36	170	88	125	22 / 4x
DN40	PN100	B1	44	36	170	88	125	22 / 4x
DN50	PN10-40	B1	57	32	165	102	125	18 / 4x
DN50	PN63	B1	57	38	180	102	135	22 / 4x
DN50	PN100	B1	57	40	195	102	145	26 / 4x
DN80	PN10-40	B1	81	36	200	138	160	18 / 8x
DN80	PN63	B1	81	40	215	138	170	22 / 8x
DN80	PN100	B1	81	44	230	138	180	26 / 8x
DN100	PN10-16	B1	81	44	220	158	180	18 / 8x
DN100	PN25-40	B1	81	36	235	162	190	22 / 8x
DN100	PN63	B1	81	42	250	162	200	26 / 8x
DN100	PN100	B1	81	48	265	162	210	30 / 8x

All dimensions in mm

JIS B2220 - RF FACING

size	rating	facing	dD	H	D	d	K	C1 / pcs
25	5K	RF	32	22	95	59	75	12 / 4x
25	10K	RF	32	26	125	67	90	19 / 4x
25	16K	RF	32	26	125	67	90	19 / 4x
25	20K	RF	32	28	125	67	90	19 / 4x
32	5K	RF	32	24	115	70	90	15 / 4x
32	10K	RF	32	28	135	76	100	19 / 4x
32	16K	RF	32	28	135	76	100	19 / 4x
32	20K	RF	32	30	135	76	100	19 / 4x
40	5K	RF	44	24	120	75	95	15 / 4x
40	10K	RF	44	28	140	81	105	19 / 4x
40	16K	RF	44	28	140	81	105	19 / 4x
40	20K	RF	44	30	140	81	105	19 / 4x
50	5K	RF	57	26	130	85	105	15 / 4x
50	10K	RF	57	28	155	96	120	19 / 4x
50	16K	RF	57	28	155	96	120	19 / 8x
50	20K	RF	57	30	155	96	120	19 / 8x
80	5K	RF	81	26	180	121	145	19 / 4x
80	10K	RF	81	30	185	126	150	19 / 8x
80	16K	RF	81	32	200	132	160	23 / 8x
80	20K	RF	81	34	200	132	160	23 / 8x
100	5K	RF	81	28	200	141	163	19 / 8x
100	10K	RF	81	30	210	151	175	19 / 8x
100	16K	RF	81	34	225	160	185	23 / 8x
100	20K	RF	81	38	225	160	185	23 / 8x

All dimensions in mm

II – DATA SHEET

FSO-BF – FLUSH DIAPHRAGM, FLANGED TYPE

DRAWING AND DIMENSIONS RJF FACING AND API

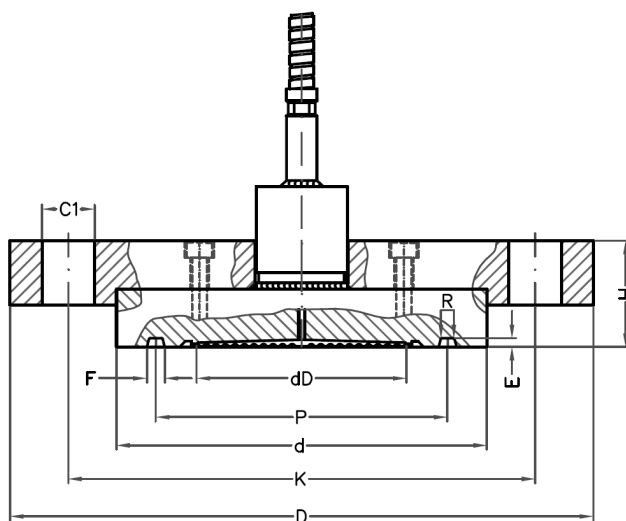

ASME B16.5 - RJF FACING

size	rating	facing	dD	H	D	d	K	C1 / pcs	C1 (inch)	P	F	E	Ring #	R
1"	cl. 150	RJF	32	27	110	64	79	16 / 4x	5/8"	48	9	6	15	0.8
1"	cl. 300	RJF	32	30	125	70	89	19 / 4x	3/4"	51	9	6	16	0.8
1"	cl. 400-600	RJF	32	32	125	70	89	19 / 4x	3/4"	51	9	6	16	0.8
1"	cl. 900-1500	RJF	32	43	150	72	102	25 / 4x	1"	51	9	6	16	0.8
1"	cl. 2500	RJF	32	49	160	83	108	25 / 4x	1"	60	9	6	18	0.8
1,5"	cl. 150	RJF	44	30	125	83	98	16 / 4x	5/8"	65	9	6	19	0.8
1,5"	cl. 300	RJF	44	33	155	91	114	22 / 4x	7/8"	68	9	6	20	0.8
1,5"	cl. 400-600	RJF	44	36	155	91	114	22 / 4x	7/8"	68	9	6	20	0.8
1,5"	cl. 900-1500	RJF	44	46	180	92	124	28 / 4x	1 1/8"	69	9	6	20	0.8
1,5"	cl. 2500	RJF	44	59	205	114	146	32 / 4x	1 1/4"	83	12	8	23	0.8
2"	cl. 150	RJF	57	32	150	102	121	19 / 4x	3/4"	83	9	6	22	0.8
2"	cl. 300	RJF	57	35	165	108	127	19 / 8x	3/4"	83	12	8	23	0.8
2"	cl. 400-600	RJF	57	44	165	108	127	19 / 8x	3/4"	83	12	8	23	0.8
2"	cl. 900-1500	RJF	57	57	215	124	165	25 / 8x	1"	95	12	8	24	0.8
2"	cl. 2500	RJF	57	70	235	133	171	28 / 8x	1 1/8"	102	12	8	26	0.8
3"	cl. 150	RJF	81	36	190	133	152	19 / 4x	3/4"	114	9	6	29	0.8
3"	cl. 300	RJF	81	41	210	146	168	22 / 8x	7/8"	124	12	8	31	0.8
3"	cl. 400-600	RJF	81	46	210	146	168	22 / 8x	7/8"	124	12	8	31	0.8
3"	cl. 900	RJF	81	52	240	156	191	25 / 8x	1"	124	12	8	31	0.8
3"	cl. 1500	RJF	81	67	265	168	203	32 / 8x	1 1/4"	137	12	8	35	0.8
3"	cl. 2500	RJF	81	86	305	168	229	35 / 8x	1 3/8"	127	14	10	32	0.8
4"	cl. 150	RJF	81	36	230	171	191	19 / 8x	3/4"	149	9	6	36	0.8
4"	cl. 300	RJF	81	44	255	175	200	22 / 8x	7/8"	149	12	8	37	0.8
4"	cl. 400	RJF	81	49	255	175	200	25 / 8x	1"	149	12	8	37	0.8
4"	cl. 600	RJF	81	52	275	175	216	25 / 8x	1"	149	12	8	37	0.8
4"	cl. 900	RJF	81	59	290	181	235	32 / 8x	1 1/4"	149	12	8	37	0.8
4"	cl. 1500	RJF	81	68	310	194	241	35 / 8x	1 3/8"	162	12	8	39	0.8
4"	cl. 2500	RJF	81	90	355	203	273	42 / 8x	1 3/8"	157	17	11	38	0.8

All dimensions in mm

II – DATA SHEET

FSO-BF – FLUSH DIAPHRAGM, FLANGED TYPE

API 6A ISO 10423 - TYPE 6BX

size	rating	dD	b	D	d4	K	C1/pcs	P	F	E	ring	R	
1-13/16"	6BX	69MPa	32mm	42	185	105	146	23 / 8x	66	11	6	BX-151	0.8
1-13/16"	6BX	103,5MPa	32mm	47	210	106	160	26 / 8x	66	11	6	BX-151	0.8
1-13/16"	6BX	138MPa	32mm	47	255	117	203	29 / 8x	66	11	6	BX-151	0.8
2-1/16"	6BX	69MPa	44mm	44	200	111	159	23 / 8x	74	12	6	BX-152	0.8
2-1/16"	6BX	103,5MPa	44mm	53	220	114	175	26 / 8x	74	12	6	BX-152	0.8
2-1/16"	6BX	138MPa	44mm	53	285	132	230	32 / 8x	74	12	6	BX-152	0.8
2-9/16"	6BX	69MPa	57mm	51	230	132	184	23 / 8x	89	14	7	BX-153	0.8
2-9/16"	6BX	103,5MPa	57mm	66	255	133	200	29 / 8x	89	14	7	BX-153	0.8
2-9/16"	6BX	138MPa	57mm	66	325	151	262	35 / 8x	89	14	7	BX-153	0.8
3-1/16"	6BX	69MPa	57mm	64	270	152	216	29 / 8x	104	15	8	BX-154	0.8
3-1/16"	6BX	103,5MPa	57mm	79	290	154	230	32 / 8x	104	15	8	BX-154	0.8
3-1/16"	6BX	138MPa	57mm	79	355	171	287	39 / 8x	104	15	8	BX-154	0.8

All dimensions in mm

API 6A ISO 10423 - TYPE 6B

size	rating	dD	H	D	d4	K	C1/pcs	P	F	E	ring	R	
2-1/16"	6B	13,8MPa	44mm	33	165	108	127	20 / 8x	83	12	8	R or RX-23	0.8
2-1/16"	6B	20,7MPa	44mm	46	215	124	165	26 / 8x	95	12	8	R or RX-24	0.8
2-1/16"	6B	34,5MPa	44mm	46	215	124	165	26 / 8x	95	12	8	R or RX-24	0.8
2-9/16"	6B	13,8MPa	57mm	36	190	127	149	23 / 8x	102	12	8	R or RX-26	0.8
2-9/16"	6B	20,7MPa	57mm	38	245	137	190	29 / 8x	108	12	8	R or RX-27	0.8
2-9/16"	6B	34,5MPa	57mm	38	245	137	190	29 / 8x	108	12	8	R or RX-27	0.8
3-1/8"	6B	13,8MPa	72mm	40	210	146	168	23 / 8x	124	12	8	R or RX-31	0.8
3-1/8"	6B	20,7Mpa	72mm	46	240	156	191	26 / 8x	124	12	8	R or RX-31	0.8
3-1/8"	6B	34,5MPa	72mm	56	265	168	203	32 / 8x	137	12	8	R or RX-35	0.8

All dimensions in mm

The FSO-BRF construction is designed to obtain a diaphragm seal with full wetted parts in exotic materials. With Badotherm’s unique resistance weld technology, a stainless steel body (non-wetted) has its wetted parts (diaphragm and raised face portion) covered by sheet material in the required exotic material. This is far more economic than producing the full flange in exotic material. FSO-BRF is typically used in combination with (differential) pressure transmitters for applications such as level, flow and (absolute) pressure measurement.



STANDARD EXECUTION

WETTED PARTS Hastelloy C-276	BODY AISI 316(L)	MOUNTING CONNECTION top (axial)	GASKET SURFACE FINISH Factory standard
FACING RF	FACING TYPE B1	SOLUTION page 124	

FLANGED PROCESS CONNECTIONS

ASME B16.5

size	rating	facing	dD
1"	cl. 150 - cl. 2500	RF	32mm
1,5"	cl. 150 - cl. 2500	RF	44mm
2"	cl. 150 - cl. 2500	RF	57mm
3"	cl. 150 - cl. 2500	RF	81mm
4"	cl. 150 - cl. 2500	RF	81mm

EN 1092-1

size	rating	form	dD
DN25	PN10 – PN100	B1	32mm
DN40	PN10 – PN100	B1	44mm
DN50	PN10 – PN100	B1	57mm
DN80	PN10 – PN100	B1	81mm
DN100	PN10 – PN100	B1	81mm

JIS B2220

Size	rating	facing	dD
25 (1")	5K – 20K	RF	32mm
32	5K – 20K	RF	32mm
40 (1,5)	5K – 20K	RF	44mm
50 (2")	5K – 20K	RF	57mm
65	5K – 20K	RF	57mm
80 (3")	5K – 20K	RF	81mm
90	5K – 20K	RF	81mm
100 (4")	5K – 20K	RF	81mm

WETTED PARTS, BODY MATERIALS, AND FACING OPTIONS

diaphragm material	body material
Monel 400	AISI 316(L)
Hastelloy C-276	
Tantalum	
Nickel 201	
Niobium	
AISI 304(L)	
AISI 321	
AISI 316 UG	
Duplex 2205	
Inconel 600	

facing (ASME B16.5)	facing type (EN 1092-1)
RF	B1
LMF	B2
SMF	E

Note: soft gasket to be used with all facings

OPTIONS

- set of handles welded on side of flange page 113
- heavy duty capillary tube page 113/123
- TR - temperature reducer page 114
- TC - temperature compensator page 114/121
- cover flange in exotic material
- degreasing of wetted parts

DRAWING AND DIMENSIONS STANDARD EXECUTIONS

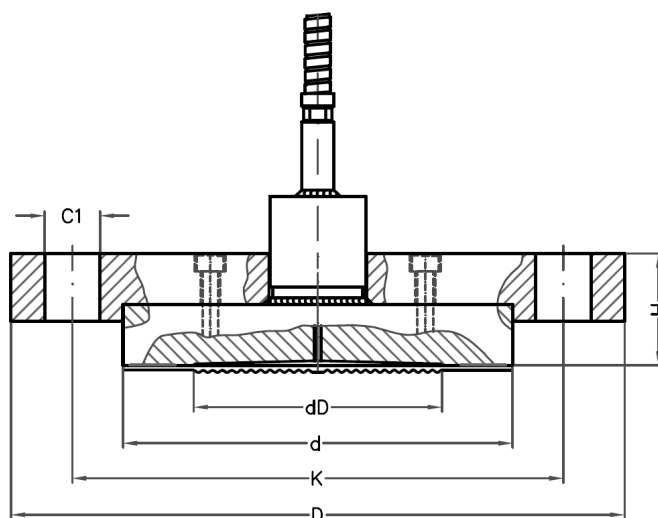

ASME B16.5 - RF FACING

size	rating	facing	dD	H	D	d	K	C1 / pcs	C1 (inch)
1"	cl. 150	RF	32	27	110	51	80	16 / 4x	5/8"
1"	cl. 300	RF	32	30	125	51	89	19 / 4x	3/4"
1"	cl. 400-600	RF	32	32	125	51	89	19 / 4x	3/4"
1"	cl. 900-1500	RF	32	43	150	51	102	25 / 4x	1"
1"	cl. 2500	RF	32	49	160	51	108	25 / 4x	1"
1,5"	cl. 150	RF	44	30	125	73	99	16 / 4x	5/8"
1,5"	cl. 300	RF	44	33	155	73	114	22 / 4x	7/8"
1,5"	cl. 400-600	RF	44	36	155	73	114	22 / 4x	7/8"
1,5"	cl. 900-1500	RF	44	46	180	73	124	29 / 4x	1 1/4"
1,5"	cl. 2500	RF	44	59	205	73	146	32 / 4x	1 1/4"
2"	cl. 150	RF	57	32	150	92	121	19 / 4x	3/4"
2"	cl. 300	RF	57	35	165	92	127	19 / 8x	3/4"
2"	cl. 400-600	RF	57	44	165	92	127	19 / 8x	3/4"
2"	cl. 900-1500	RF	57	57	215	92	165	25 / 8x	1"
2"	cl. 2500	RF	57	70	235	92	171	29 / 8x	1 1/8"
3"	cl. 150	RF	81	36	190	127	152	19 / 4x	3/4"
3"	cl. 300	RF	81	41	210	127	168	22 / 8x	7/8"
3"	cl. 400-600	RF	81	46	210	127	168	22 / 8x	7/8"
3"	cl. 900	RF	81	52	240	127	191	25 / 8x	1"
3"	cl. 1500	RF	81	67	265	127	203	32 / 8x	1 1/4"
3"	cl. 2500	RF	81	86	305	127	229	35 / 8x	1 1/2"
4"	cl. 150	RF	81	36	230	157	191	19 / 8x	3/4"
4"	cl. 300	RF	81	44	255	157	200	22 / 8x	7/8"
4"	cl. 400	RF	81	49	255	157	200	25 / 8x	1"
4"	cl. 600	RF	81	52	275	157	216	25 / 8x	1"
4"	cl. 900	RF	81	59	290	157	235	32 / 8x	1 1/4"
4"	cl. 1500	RF	81	68	310	157	241	35 / 8x	1 1/2"
4"	cl. 2500	RF	81	90	355	157	273	42 / 8x	1 1/2"

All dimensions in mm

II – DATA SHEET

FSO-BRF – FLUSH DIAPHRAGM, EXOTIC WETTED PARTS, FLANGED TYPE

EN 1092-1 - TYPE B1

size	rating	type	dD	H	D	d	K	C1 / pcs
DN25	PN10-40	B1	32	30	115	68	85	14 / 4x
DN25	PN63	B1	32	36	140	68	100	18 / 4x
DN25	PN100	B1	32	36	140	68	100	18 / 4x
DN40	PN10-40	B1	44	30	150	88	110	18 / 4x
DN40	PN63	B1	44	36	170	88	125	22 / 4x
DN40	PN100	B1	44	36	170	88	125	22 / 4x
DN50	PN10-40	B1	57	32	165	102	125	18 / 4x
DN50	PN63	B1	57	38	180	102	135	22 / 4x
DN50	PN100	B1	57	40	195	102	145	26 / 4x
DN80	PN10-40	B1	81	36	200	138	160	18 / 8x
DN80	PN63	B1	81	40	215	138	170	22 / 8x
DN80	PN100	B1	81	44	230	138	180	26 / 8x
DN100	PN10-16	B1	81	44	220	158	180	18 / 8x
DN100	PN25-40	B1	81	36	235	162	190	22 / 8x
DN100	PN63	B1	81	42	250	162	200	26 / 8x

All dimensions in mm

JIS B2220 - RF FACING

size	rating	facing	dD	H	D	d	K	C1 / pcs
25	5K	RF	32	22	95	59	75	12 / 4x
25	10K	RF	32	26	125	67	90	19 / 4x
25	16K	RF	32	26	125	67	90	19 / 4x
25	20K	RF	32	28	125	67	90	19 / 4x
32	5K	RF	32	24	115	70	90	15 / 4x
32	10K	RF	32	28	135	76	100	19 / 4x
32	16K	RF	32	28	135	76	100	19 / 4x
32	20K	RF	32	30	135	76	100	19 / 4x
40	5K	RF	44	24	120	75	95	15 / 4x
40	10K	RF	44	28	140	81	105	19 / 4x
40	16K	RF	44	28	140	81	105	19 / 4x
40	20K	RF	44	30	140	81	105	19 / 4x
50	5K	RF	57	26	130	85	105	15 / 4x
50	10K	RF	57	28	155	96	120	19 / 4x
50	16K	RF	57	28	155	96	120	19 / 8x
50	20K	RF	57	30	155	96	120	19 / 8x
65	5K	RF	57	26	155	110	130	15 / 4x
65	10K	RF	57	30	175	116	140	19 / 4x
65	16K	RF	57	30	175	116	140	19 / 8x
65	20K	RF	57	32	175	116	140	19 / 8x
80	5K	RF	81	26	180	121	145	19 / 4x
80	10K	RF	81	30	185	126	150	19 / 8x
80	16K	RF	81	32	200	132	160	23 / 8x
80	20K	RF	81	34	200	132	160	23 / 8x
90	5K	RF	81	26	190	131	155	19 / 4x
90	10K	RF	81	30	195	136	160	19 / 8x
90	16K	RF	81	32	210	145	170	23 / 8x
90	20K	RF	81	36	210	145	170	23 / 8x
100	5K	RF	81	28	200	141	163	19 / 8x
100	10K	RF	81	30	210	151	175	19 / 8x
100	16K	RF	81	34	225	160	185	23 / 8x
100	20K	RF	81	38	225	160	185	23 / 8x

All dimensions in mm

The FSO-EXT is typically used in combination with (differential) pressure transmitters for level, flow and pressure measurement, in those applications where the diaphragm need to be flush with the vessel wall or where insulation layers need to be passed. The FSO-EXT is recommended when extended seals are required fully in exotic materials and/or when special grade flanges are required.



STANDARD EXECUTION

DIAPHRAGM	BODY	MOUNTING CONNECTION
AISI 316(L)	AISI 316(L)	top (axial)
FACING	FACING TYPE	STANDARD LENGTH
RF	B1	50/100/150/200 mm

FLANGED PROCESS CONNECTIONS

ASME B16.5

size	rating	facing	dD
2"	cl. 150 - cl. 2500	RF	44mm
3"	cl. 150 - cl. 2500	RF	72mm
4"	cl. 150 - cl. 2500	RF	81mm

EN 1092-1

size	rating	type	dD
DN50	PN10-100	B1	44mm
DN80	PN10-100	B1	72mm
DN100	PN10-100	B1	81mm

WETTED PARTS, BODY MATERIALS, AND FACING OPTIONS

diaphragm material	body material
AISI 316(L)	AISI 316(L)
AISI 304(L)	
AISI 321	
AISI 316 UG	
Hastelloy C-276	
Monel 400	Monel 400
Hastelloy C-276	Hastelloy C-276
Duplex 2205	Super Duplex / Duplex
Inconel 600	Inconel 600
Titanium Gr. 1	Titanium Gr. 2
Nickel 201	Nickel 201

facing (ASME B16.5)	
RF	Ra 3.2-6.3 µm
RJF	Ra <1.6 µm
LMF	Ra 3.2-6.3 µm
SMF	Ra <3.2 µm
LTF	Ra <3.2 µm
STF	Ra <3.2 µm
LGF	Ra <3.2 µm
SGF	Ra <3.2 µm

facing type (EN 1092-1)	
B1	Ra 3.2-12.5 µm
B2	Ra 0.8-3.2 µm
C	Ra 0.8-3.2 µm
D	Ra 0.8-3.2 µm
E	Ra 3.2-12.5 µm
F	Ra 3.2-12.5 µm

COATING AND OTHER OPTIONS

COATINGS

- gold: 25 µm / 40 µm hydrogen permeation protection (diaphragm only – page 120)
- PTFE / ECTFE for anti stick purpose only
- Tantaline wetted parts
- FEP / PFA
- thermal spray

OTHER OPTIONS

- set of handles welded on side of flange page 113
- heavy duty capillary tube page 113/123
- TR - temperature reducer page 114
- TC - temperature compensator page 114/121
- capillary side mounted (radial)
- PTFE sleeve / lining
- customized length and diameter
- degreased wetted parts
- polished extension
- tapered extension
- cover flange in exotic material

II – DATA SHEET

FSO-EXT – EXTENDED DIAPHRAGM, FLANGED TYPE

DRAWING AND DIMENSIONS STANDARD EXECUTIONS

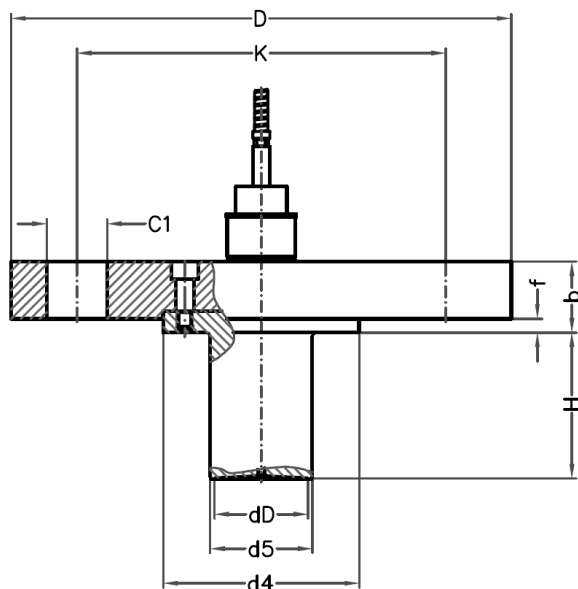

ASME B16.5 - RF FACING

size	rating	facing	dD	b	D	f	d4	d5	H	K	C1 / pcs	C1 (inch)
2"	cl. 150	RF	44	19	150	2	92	48	various	121	19 / 4x	3/4"
2"	cl. 300	RF	44	23	165	2	92	48	various	127	19 / 8x	3/4"
2"	cl. 400-600	RF	44	32	165	7	92	48	various	127	19 / 8x	3/4"
2"	cl. 900-1500	RF	44	45	215	7	92	48	various	165	25 / 8x	1"
2"	cl. 2500	RF	44	57	235	7	92	48	various	171	29 / 8x	1 1/8"
3"	cl. 150	RF	72	24	190	2	127	76	various	152	19 / 4x	3/4"
3"	cl. 300	RF	72	29	210	2	127	76	various	168	22 / 8x	7/8"
3"	cl. 400-600	RF	72	39	210	7	127	76	various	168	22 / 8x	7/8"
3"	cl. 900	RF	72	45	240	7	127	76	various	191	25 / 8x	1"
3"	cl. 1500	RF	72	55	265	7	127	76	various	203	32 / 8x	1 1/4"
3"	cl. 2500	RF	72	74	305	7	127	76	various	229	35 / 8x	1 3/8"
4"	cl. 150	RF	81	24	230	2	157	93	various	191	19 / 8x	3/4"
4"	cl. 300	RF	81	32	255	2	157	93	various	200	22 / 8x	7/8"
4"	cl. 400	RF	81	42	255	7	157	93	various	200	25 / 8x	1"
4"	cl. 600	RF	81	45	275	7	157	93	various	216	25 / 8x	1"
4"	cl. 900	RF	81	52	290	7	157	93	various	235	32 / 8x	1 1/4"
4"	cl. 1500	RF	81	61	310	7	157	93	various	241	35 / 8x	1 3/8"
4"	cl. 2500	RF	81	83	355	7	157	93	various	273	42 / 8x	1 5/8"

All dimensions in mm

EN 1092-1 - TYPE B1

size	rating	type	dD	b	D	f	d4	d5	H	K	C1 / pcs
DN50	PN10-40	B1	44	20	165	3	102	48	various	125	18 / 4x
DN50	PN63	B1	44	26	180	3	102	48	various	135	22 / 4x
DN50	PN100	B1	44	28	195	3	102	48	various	145	26 / 4x
DN80	PN10-40	B1	72	24	200	3	138	76	various	160	18 / 8x
DN80	PN63	B1	72	28	215	3	138	76	various	170	22 / 8x
DN80	PN100	B1	72	32	230	3	138	76	various	180	26 / 8x
DN100	PN10-16	B1	81	20	220	3	158	93	various	180	18 / 8x
DN100	PN25-40	B1	81	24	235	3	162	93	various	190	22 / 8x
DN100	PN63	B1	81	30	250	3	162	93	various	200	26 / 8x
DN100	PN100	B1	81	36	265	3	162	93	various	210	30 / 8x

All dimensions in mm

The UST construction is designed for those applications where the existing threaded process connection is too small to use a flush diaphragm seal. The UST consists of an upper and lower housing, the upper is the actual seal part with a diaphragm size that allows for measurement of relatively low ranges (200 mbar 2 seals attached (dP); 800 mbar single seal attached). The lower housing creates the transition from the diaphragm size to the actual small process connection. UST is typically used in combination with (differential) pressure transmitters for applications such as level, flow and pressure measurement; also the UST is often combined with pressure gauges.



STANDARD EXECUTION

DIAPHRAGM	BODY	MOUNTING CONNECTION
AISI 316(L)	AISI 316(L)	top (axial)

GASKET	BOLTS
PTFE	3/8" UNF – A2-70

THREADED PROCESS CONNECTIONS

NPT

size		dD
1/2"	Male or female	50mm
3/4"	Male or female	50mm
1"	Male or female	50mm

BSP

size		dD
1/2"	Male or female	50mm
3/4"	Male or female	50mm
1"	Male or female	50mm

UPPER AND LOWER PART ASSEMBLY

BOLTING

thread	material	mwp	pcs
3/8" UNF	A2-70	125 bar	4
3/8" UNF	A2-70	250 bar	8
3/8" UNF	8.8	150 bar	4
3/8" UNF	8.8	300 bar	8

GASKET

material	Operating temperature
Virgin PTFE	-200 / +260°C
Garfite N	-73 / +343°C
Camprofile ¹	-200 /+ 500°C

¹ for steam applications

Note: mwp (maximum working pressure) at 20 °C with AISI 316(L) body material

WETTED PARTS, BODY MATERIALS, AND THREADS

diaphragm mat.	body material	lowerpart material
AISI 316(L)	AISI 316(L)	AISI 316(L)
AISI 304(L)		
AISI 321		
AISI 316 UG		
Hastelloy C-276		
Hastelloy C-276	AISI 316(L)	Hastelloy C-276
Monel 400	AISI 316(L)	Monel 400
Tantalum	AISI 316(L)	Tantalum*
Nickel 201	AISI 316(L)	Nickel 201
Duplex 2205	AISI 316(L)	Duplex
Inconel 600	AISI 316(L)	Inconel 600
Titanium Gr. 1	Titanium Gr.2	Titanium Gr.2

*Note: material AISI316(L) with tantalum treatment

threads	norms
NPT	ANSI B1.20.1
BSP	ISO 228
BSPT	ISO 7
UNF	ANSI 131.1
METRIC	ISO 965

COATING AND OTHER OPTIONS

COATINGS

- gold: 25 µm / 40 µm chemical resistance and/or hydrogen permeation protection (facing and/or diaphragm – page 120)
- PTFE / ECTFE for anti stick purpose only (upper part)
- FEP / PFA (upper part)
- Tantaline wetted parts
- PTFE lining (lower part; BSP male only)

OTHER OPTIONS

- heavy duty capillary tube page 113/123
- TR - temperature reducer page 114
- PTFE sheet for anti-stick purpose only (no vacuum)
- flushing ports in lower part (not in combination with lining)
- degreasing of wetted parts

DRAWING AND DIMENSIONS STANDARD EXECUTIONS

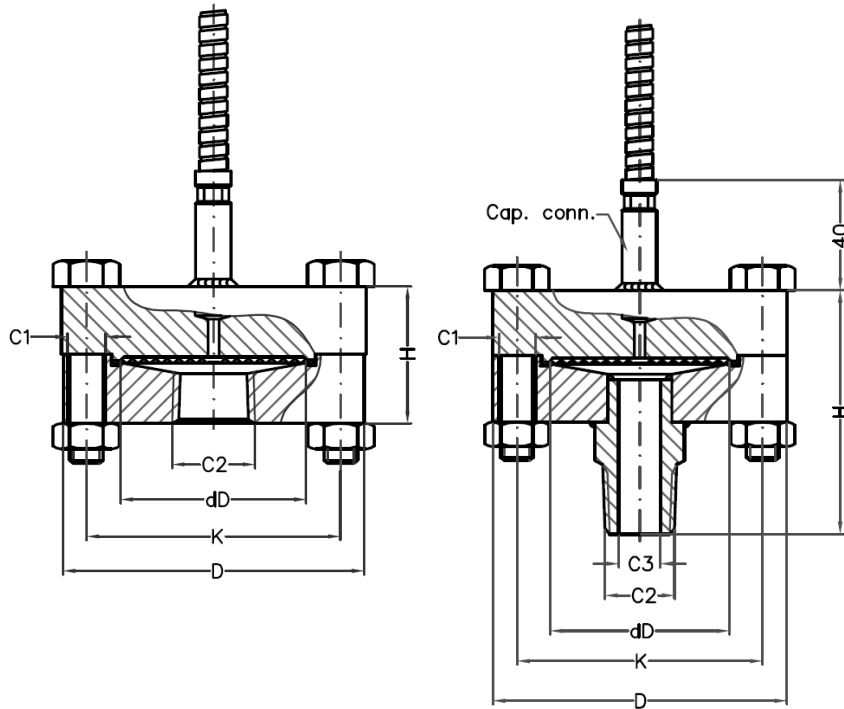

C2		C1	dD	C3	D	K	H
1/2"	female	3/8" UNF/4;8 pcs	51	-	85	70	38
3/4"	female	3/8" UNF/4;8 pcs	51	-	85	70	45
1"	female	3/8" UNF/4;8 pcs	51	-	85	70	45
1/2"	male	3/8" UNF/4;8 pcs	51	12	85	70	69
3/4"	male	3/8" UNF/4;8 pcs	51	12	85	70	72
1"	male	3/8" UNF/4;8 pcs	51	12	85	70	88

All dimensions in mm

The USLT construction is designed for those applications where the existing threaded process connection is too small to use a flush diaphragm seal. The USLT consists of an upper and lower housing, the upper is the actual seal part with a diaphragm size that allows for measurement of relatively low ranges (10 mbar 2 seals attached (dP); 80 mbar single seal attached). The lower housing creates the transition from the diaphragm size to the smaller process connection. USLT is used in combination with (differential) pressure transmitters for applications such as level, flow and pressure measurement; also the USLT is often combined with pressure gauges.

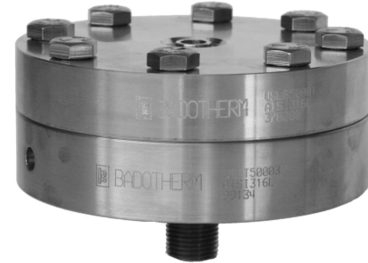

STANDARD EXECUTION

DIAPHRAGM	BODY	MOUNTING CONNECTION
AISI 316(L)	AISI 316(L)	top (axial)

GASKET	BOLTS
PTFE	M10 – A2-70

THREADED PROCESS CONNECTIONS

NPT

size		dD
1/2"	Male or female	81mm
3/4"	Male or female	81mm
1"	Male or female	81mm

BSP – ISO 228

size		dD
1/2"	Male or female	81mm
3/4"	Male or female	81mm
1"	Male or female	81mm

UPPER AND LOWER PART ASSEMBLY

BOLTING

thread	material	mwp	pcs
M10	A2-70	100 bar	8
M10	8.8	120 bar	8

Note: mwp (maximum working pressure) at 20 °C with AISI 316(L) body material

GASKET

material	Operating temperature
PTFE	-200 / +260°C
Garfite N	-73 / +343°C
Camprofile ¹	-200 / 500°C

¹ for steam applications

WETTED PARTS, BODY MATERIALS, AND THREADS

diaphragm mat.	body material	lowerpart material
AISI 316(L)	AISI 316(L)	AISI 316(L)
AISI 304(L)		
AISI 321		
AISI 316 UG		
Hastelloy C-276		
Hastelloy C-276	AISI 316(L)	Hastelloy C-276
Monel 400	AISI 316(L)	Monel 400
Tantalum	AISI 316(L)	Tantalum*
Nickel 201	AISI 316(L)	Nickel 201
Duplex 2205	AISI 316(L)	Duplex
Inconel 600	AISI 316(L)	Inconel 600
Titanium Gr. 1	Titanium Gr.2	Titanium Gr.2

*Note: material AISI316(L) with tantalum treatment

threads	norms
NPT	ANSI B1.20.1
BSP	ISO 228
BSPT	ISO 7
UNF	ANSI 131.1
METRIC	ISO 965

COATING AND OTHER OPTIONS

COATINGS

- gold: 25 µm / 40 µm chemical resistance and/or hydrogen permeation protection (facing and/or diaphragm – page 120)
- PTFE / ECTFE for anti stick purpose only (upper part)
- FEP / PFA (upper part)
- Tantaline wetted parts
- PTFE lining (lower part; BSP male only)

OTHER OPTIONS

- heavy duty capillary tube page 113/123
- TR - temperature reducer page 114
- TC - temperature compensator page 114/121
- PTFE sheet for anti-stick purpose only (no vacuum)
- flushing ports in lower part (not in combination with lining)
- LGP – execution for low pressures page 119
- degreasing of wetted parts

DRAWING AND DIMENSIONS STANDARD EXECUTIONS

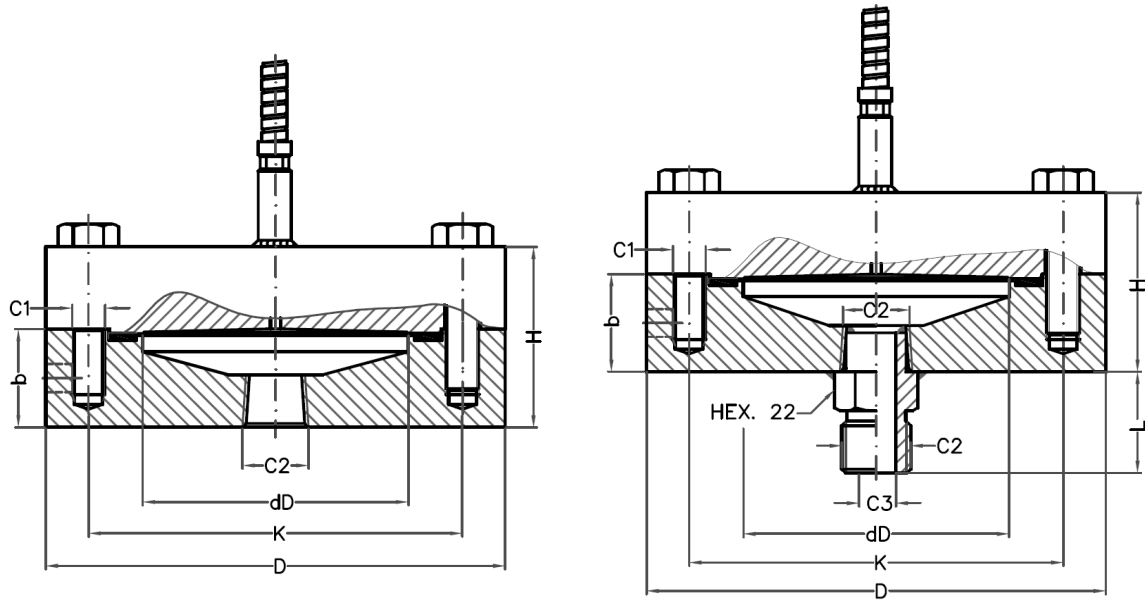

C2	C1	dD	C3	D	K	H	b	L
1/2" female	M10 / 8 pcs	81	-	140	114	55	30	-
3/4" female	M10 / 8 pcs	81	-	140	114	55	30	-
1" female	M10 / 8 pcs	81	-	140	114	55	30	-
1/2" male	M10 / 8 pcs	81	12	140	114	86	30	31
3/4" male	M10 / 8 pcs	81	12	140	114	89	30	34
1 male	M10 / 8 pcs	81	12	140	114	105	30	50

All dimensions in mm

The ECx is a complete welded construction and designed for those applications where the process conditions are such that direct mounting of the instrument cannot be done. Applications are aggressive media, waste water treatment, or when special wetted parts materials for pressure gauges are required. ECx is typically used in combination with pressure gauges.



STANDARD EXECUTION – ECA / ECB / ECE / ECH

DIAPHRAGM	BODY	MOUNTING CONNECTION	CONSTRUCTION
AISI 316(L)	AISI 316(L)	top (axial)	welded

THREADED PROCESS CONNECTIONS

ECA - NPT / BSP

size		mwp	dD
1/2"	Male or Female	400 bar	32mm
1/4"	Male or Female	400 bar	32mm

Note: mwp (maximum working pressure) at 20 °C with AISI 316(L) body material

ECB - NPT / BSP

size		mwp	dD
1/2"	Male or Female	60 bar	51mm
1/4"	Male or Female	60 bar	51mm

Note: mwp (maximum working pressure) at 20 °C with AISI 316(L) body material

ECE - NPT / BSP

size		mwp	dD
1/2"	Male or Female	400 bar	23mm
1/4"	Male or Female	400 bar	23mm

Note: mwp (maximum working pressure) at 20 °C with AISI 316(L) body material

ECH - NPT / BSP

size		mwp	dD
1/2"	Male or Female	1000 bar	35mm
1/4"	Male or Female	1000 bar	35mm

Note: mwp (maximum working pressure) at 20 °C with AISI 316(L) body material

WETTED PARTS, BODY MATERIALS, AND THREADS

diaphragm mat.	body material	lowerpart material
AISI 316(L)	AISI 316(L)	AISI 316(L)
Hastelloy C-276	Hastelloy C-276	Hastelloy C-276
Monel 400	Monel 400	Monel 400
Duplex 2205	Duplex	Duplex

threads	norms
NPT	ANSI B1.20.1
BSP	ISO 228
BSPT	ISO 7
UNF	ANSI 131.1
METRIC	ISO 965

DRAWING AND DIMENSIONS STANDARD EXECUTIONS – ECB / ECE

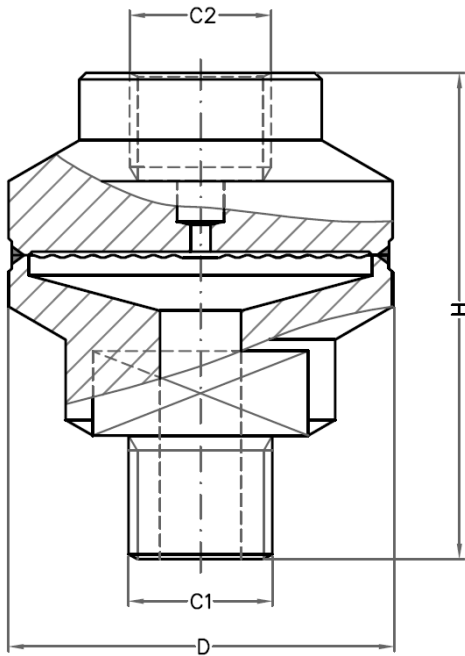

ECB

C1	C2	D	H
1/2" NPT-f	1/2" BSP-f	57	57
1/2" BSP-f	1/2" BSP-f	57	57
1/2" NPT-m	1/2" BSP-f	57	77
1/2" BSP-m	1/2" BSP-f	57	77

All dimensions in mm

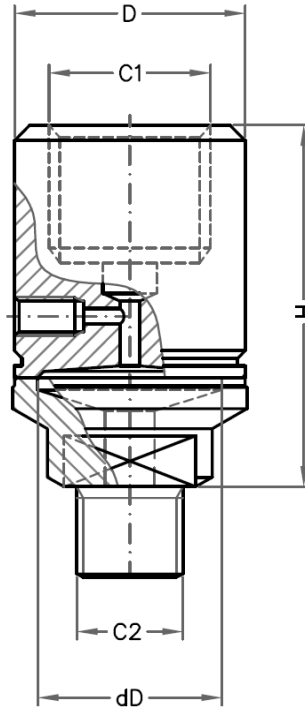

ECE

C1	C2	D	H	dD
1/2" NPT-f	1/2" BSP-f	30	57	23
1/2" BSP-f	1/2" BSP-f	30	57	23
1/2" NPT-m	1/2" BSP-f	30	77	23
1/2" BSP-m	1/2" BSP-f	30	77	23

All dimensions in mm

DRAWING AND DIMENSIONS STANDARD EXECUTIONS – ECA / ECH

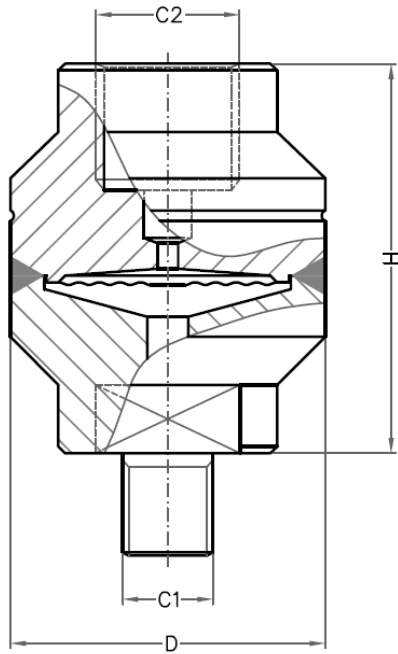

ECA

C1	C2	D	H
1/2" NPT-f	1/2" BSP-f	46	58
1/2" BSP-f	1/2" BSP-f	46	58
1/2" NPT-m	1/2" BSP-f	46	78
1/2" BSP-m	1/2" BSP-f	46	78

All dimensions in mm

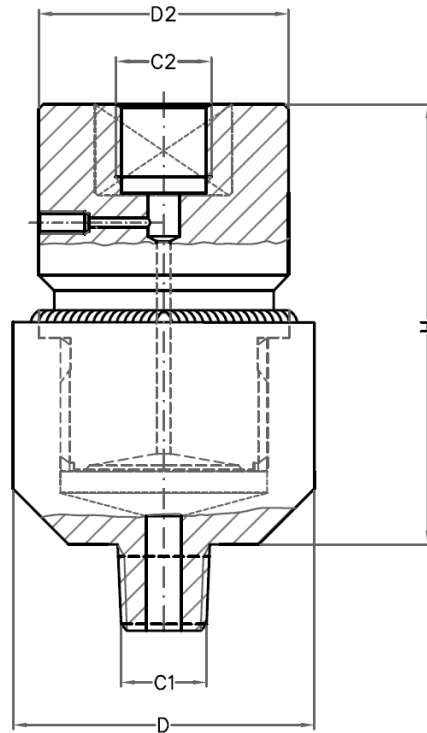

ECH

C1	C2	D	D2	H
1/2" NPT-f	1/2" BSP-f	70	55	100
1/2" BSP-f	1/2" BSP-f	70	55	100
1/2" NPT-m	1/2" BSP-f	70	55	100
1/2" BSP-m	1/2" BSP-f	70	55	100

All dimensions in mm

The PS construction is designed for those applications where the process is very viscous and/or containing parts that might obstruct the process connection of the instrument. Typical applications can be found in pulp & paper industries and waste water treatment. The PS is a single part construction. PS is typically used in combination with pressure transmitters and gauges for pressure measurement.



STANDARD EXECUTION

DIAPHRAGM	BODY	MOUNTING CONNECTION
AISI 316(L)	AISI 316(L)	top (axial)

THREADED PROCESS CONNECTIONS

NPT

size		mwp	dD
1/2"	Male	600 bar	17mm
3/4"	Male	600 bar	20mm
1"	Male	600 bar	25mm
1,5"	Male	400 bar	32mm
2"	Male	280 bar	44mm

Note: mwp at 20 °C with AISI 316(L) body material

BSP

size		mwp	dD
1/2"	Male	600 bar	17mm
3/4"	Male	600 bar	20mm
1"	Male	600 bar	25mm
1,5"	Male	400 bar	32mm
2"	Male	280 bar	44mm

Note: mwp at 20 °C with AISI 316(L) body material

Note: gasket surface according ISO 1179-3

WETTED PARTS, BODY MATERIALS, AND THREADS

diaphragm mat.	body material
AISI 316(L)	AISI 316(L)
Hastelloy C-276	
Hastelloy C-276	Hastelloy C-276
Duplex 2205	Super Duplex / Duplex
Monel 400	Monel 400

threads	norms
NPT	ANSI B1.20.1
BSP	ISO 228
BSPT	ISO 7
UNF	ANSI 131.1
METRIC	ISO 965

OPTION

- Tantaline wetted parts

DRAWING AND DIMENSIONS STANDARD EXECUTIONS

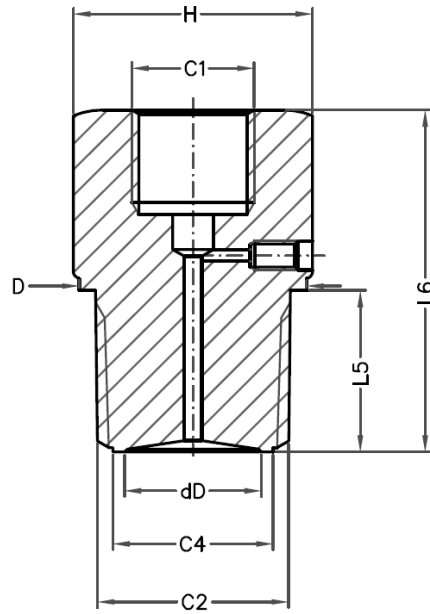

C2	C1	dD	C4	H	D ¹	L5	L6
1/2" Male	1/2" BSP-f	14	17	SW 27	30	27	47
3/4" Male	1/2" BSP-f	20	23	SW 32	32	28	52
1" Male	1/2" BSP-f	24	28	SW 46	45	28	58
1.5" Male	1/2" BSP-f	35	42	SW 46	55	34	64
2" Male	1/2" BSP-f	44	47	SW 54	62	37	65

¹ For BSP thread; dimensions according ISO 1179
All dimensions in mm

Badotherm sanitary seals are designed for pressure, level and flow measurements in food & beverage and pharmaceutical industries where the formation of bacteria needs to be prevented by reducing or eliminating blind spaces where process product could remain and thus creating impurities, bacteria by e.g. fermentation. As such these seals allow for easy cleaning by means of either threaded or clamp quick couplings. These seals are standard in stainless steel AISI 316(L). All these seals and fill fluid are suitable for CIP (Cleaning In Process) applications. Other aseptic flanged sanitary connections are available on request.



STANDARD EXECUTION – SAF / SAM

DIAPHRAGM	BODY	SURFACE FINISH WETTED PARTS	MOUNTING CONNECTION
AISI 316(L)	AISI 316(L)	Ra < 0,8 µm	top (axial)

COUPLING NUT SAF
AISI 304

FEMALE THREADED PROCESS CONNECTIONS - SAF

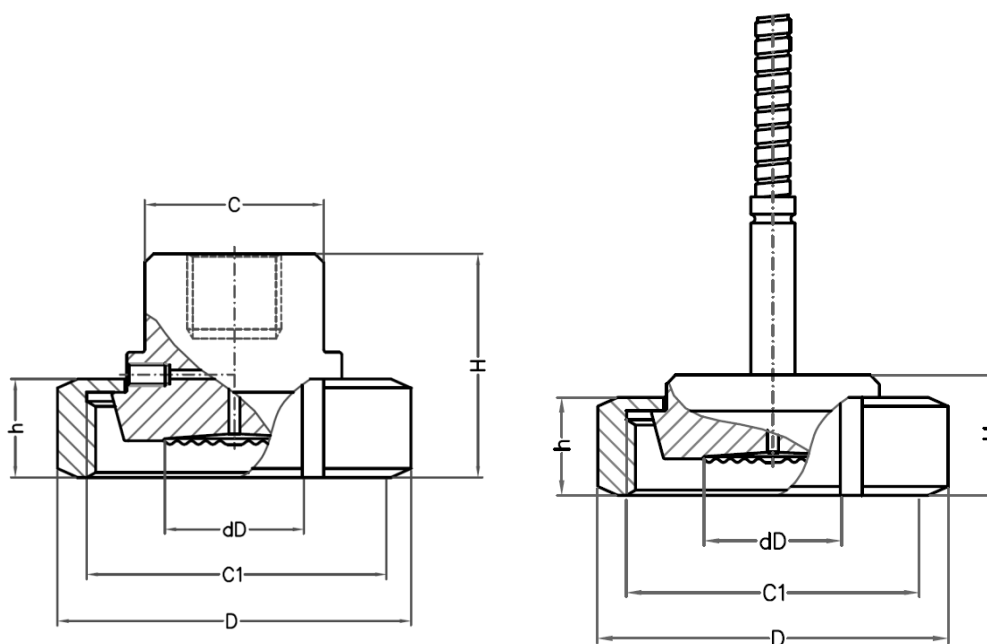

DIN 11851

size	rating	dD	D	h	C1	H
DN25	PN40	20	63	21	Rd52 x 1/6"	21
DN32	PN40	25	70	21	Rd58 x 1/6"	21
DN40	PN40	32	78	21	Rd65 x 1/6"	21
DN50	PN25	44	92	22	Rd78 x 1/6"	22
DN80	PN25	72	127	30	Rd110 x 1/6"	29

All dimensions in mm

SMS 1145

size	rating	dD	D	h	C1	H
1,5"	PN40	32	74	25	Rd60 x 1/6"	25
2"	PN40	44	84	26	Rd70 x 1/6"	26

All dimensions in mm

MALE THREADED PROCESS CONNECTIONS - SAM

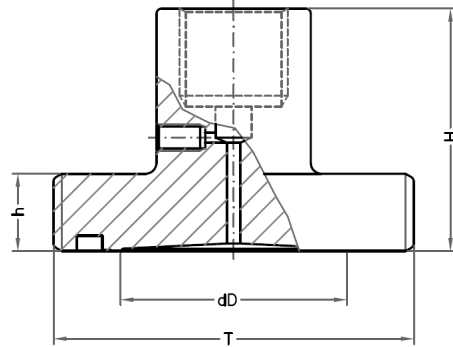

DIN 11851

size	rating	dD	h	T	H
DN25	PN40	20	15	Rd52 x 1/6"	50
DN32	PN40	25	15	Rd58 x 1/6"	50
DN40	PN40	32	15	Rd65 x 1/6"	50
DN50	PN25	44	15	Rd78 x 1/6"	50
DN80	PN25	72	21	Rd110 x 1/6"	50

All dimensions in mm

SMS 1145

size	rating	dD	h	C1	H
1,5"	PN40	32	15	Rd60*1/6	50
2"	PN40	44	15	Rd70*1/6	50

All dimensions in mm

STANDARD EXECUTION – SAT

DIAPHRAGM	BODY	SURFACE FINISH WETTED PARTS	MOUNTING CONNECTION
AISI 316(L)	AISI 316(L)	Ra < 0,8 µm	top (axial)

CLAMP PROCESS CONNECTIONS – SAT

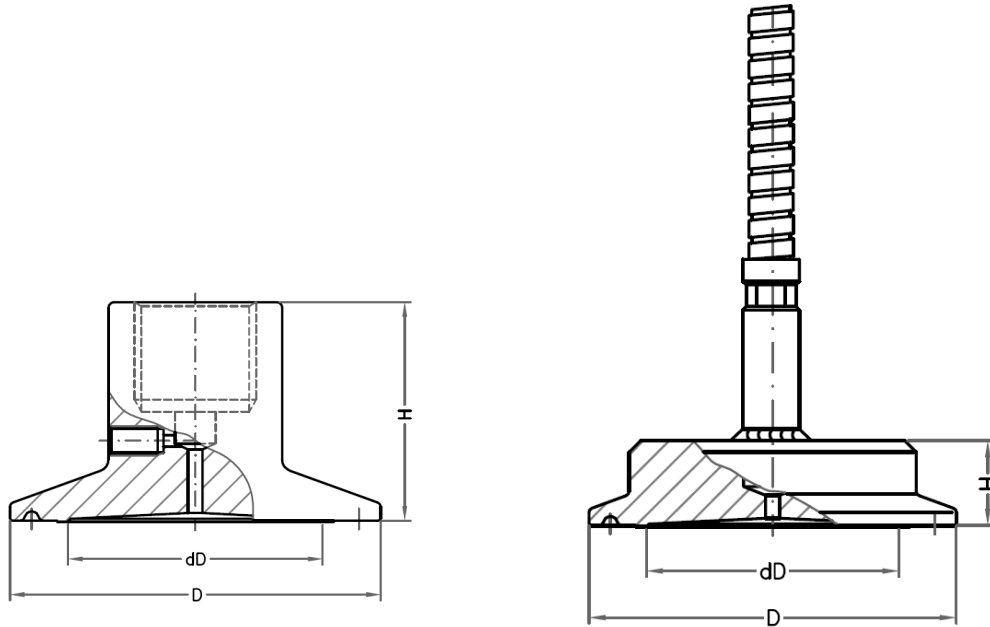

TRI-CLAMP ISO - 2852

size	DN	rating	dD	D	H _{thread}	H _{capillary}
1,5"	25	PN40	32	51	38	15
2"	40	PN40	44	64	38	15
2,5"	63.5	PN25	52	78	31	15
3"	76.1	PN25	72	91	31	15
4"	101.6	PN25	81	119	31	15

Note: for maximum pressure rating refer to the clamp specifications; dimensions suitable for pipe per ISO 2037 and BS 4825 part 1
All dimensions in mm

TRI-CLAMP DN 32676

size	rating	dD	D	H _{thread}	H _{capillary}
25	PN40	32mm	51	38	15
40	PN40	44mm	64	38	15
65	PN25	52mm	78	31	15
80	PN25	72mm	91	31	15
100	PN25	81mm	119	31	15

Note: for maximum pressure rating refer to the clamp specifications; dimensions suitable for pipe acc DIN 11866 row A or DIN 11850 row 2
All dimensions in mm

STANDARD EXECUTION – SA-TS

DIAPHRAGM AISI 316(L)	BODY AISI 316(L)	SURFACE FINISH WETTED PARTS Ra < 0,8 µm	MOUNTING CONNECTION top (axial)
--------------------------	---------------------	--	------------------------------------

CLAMP PROCESS CONNECTIONS – SA-TS

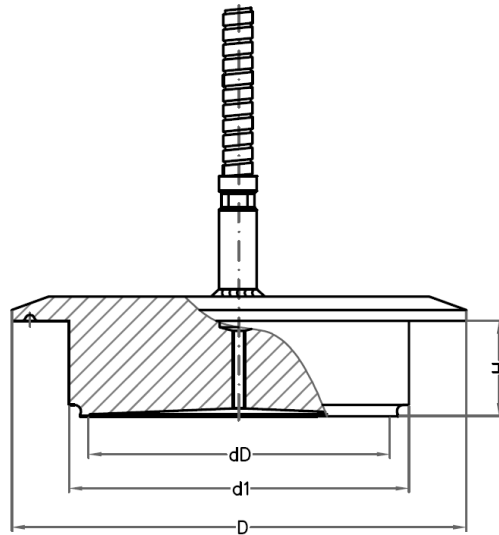

TANK SPUD

Extension length	rating	dD	D	d1	H
2"	PN40	81	133	100	51
6"	PN40	81	133	100	152

All dimensions in mm

STANDARD EXECUTION – SA-V

DIAPHRAGM AISI 316(L)	BODY AISI 316(L)	SURFACE FINISH WETTED PARTS Ra < 0,8 µm	MOUNTING CONNECTION top (axial)
--------------------------	---------------------	--	------------------------------------

CLAMP PROCESS CONNECTIONS – SA-V

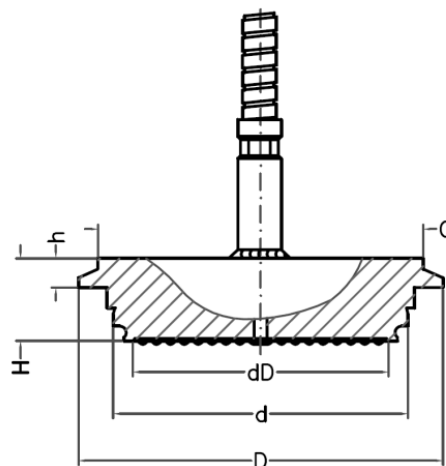

VARIVENT®

Connection	Size VARILINE®	rating	dD	d	D	H	h	C	Clamp
Type F	DN25/ISO25 and 1"	PN40	44	50	66	19	7	57	66
Type N	DN40-DN125 / ISO32-100 and 1.5"-6"	PN40	57	68	84	19	7	75	84

All dimensions in mm

STANDARD EXECUTION – SA-HOM

DIAPHRAGM AISI 316(L)	BODY AISI 316(L)	SURFACE FINISH WETTED PARTS Ra < 0,8 µm	MOUNTING CONNECTION top (axial)
--------------------------	---------------------	--	------------------------------------

HOMOGENISER PROCESS CONNECTIONS – SA-HOM

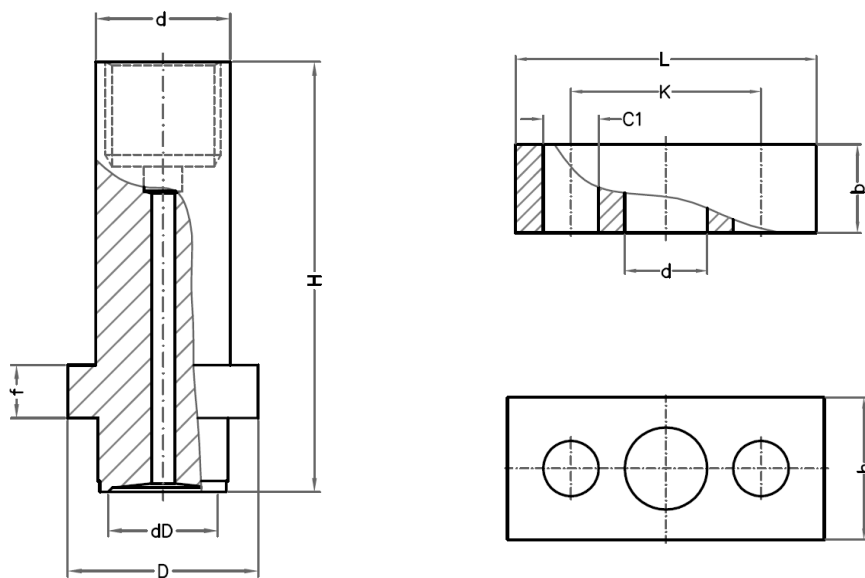

size	rating	dD	D	H	f	d	b	C1	K	Lxh
Block 95x45	PN600	20	33.5	93	13.5	22		17.5	60	95x45

All dimensions in mm

ILSF is typically used in combination with pressure transmitters for pressure measurement (≥ 2 barg) applications. Its pressure rating is defined by the flanges between which it is clamped and as such it can be used for all pressure ratings.



STANDARD EXECUTION

DIAPHRAGM	BODY	MOUNTING CONNECTION
AISI 316(L)	AISI 316(L)	side (radial)
FACING	TYPE	
RF	type B1	

FLANGED PROCESS CONNECTIONS

ASME B16.5

size	rating
1"	cl. 150 – cl. 2500
1.5"	cl. 150 – cl. 2500
2"	cl. 150 – cl. 2500
3"	cl. 150 – cl. 2500
4"	cl. 150 – cl. 2500
5"	cl. 150 – cl. 2500
6"	cl. 150 – cl. 2500

EN 1092-1

size	rating
DN25	PN10 – PN400
DN40	PN10 – PN400
DN50	PN10 – PN400
DN80	PN10 – PN400
DN100	PN10 – PN400
DN125	PN10 – PN400
DN150	PN10 – PN400

WETTED PARTS, BODY MATERIALS, AND FACING OPTIONS

diaphragm material	body material
AISI 316(L)	AISI 316(L)
Hastelloy C-276	
Hastelloy C4	

facing (ASME B16.5)	
RF	Ra 3.2-6.3 μm
LGF	Ra <3.2 μm
LMF	Ra 3.2-6.3 μm

facing type (EN 1092-1)	
B1	Ra 3.2-12.5 μm
B2	Ra 0.8-3.2 μm
D	Ra 0.8-3.2 μm
E	Ra 3.2-12.5 μm

OPTION

- Sanitary connection

DRAWING AND DIMENSIONS STANDARD EXECUTIONS

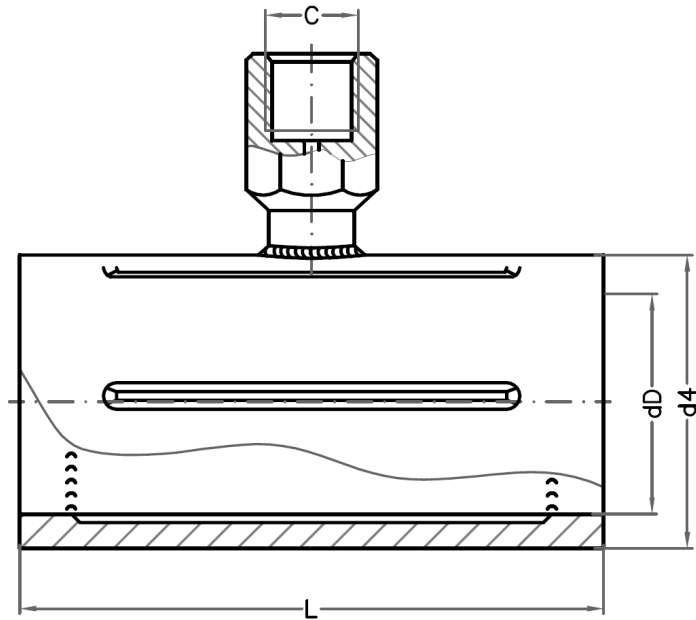

ASME B16.5 - RF FACING

size	rating	facing	dD	d4	L	L(optional)
1"	cl. 150 – cl. 2500	RF	29	50	100	60
1.5"	cl. 150 – cl. 2500	RF	43	73	100	60
2"	cl. 150 – cl. 2500	RF	55	92	100	60
2.5"	cl. 150 – cl. 2500	RF	70	105	100	60
3"	cl. 150 – cl. 2500	RF	83	127	60	100
4"	cl. 150 – cl. 2500	RF	107	157	60	100
5"	cl. 150 – cl. 2500	RF	127	188	60	100
6"	cl. 150 – cl. 2500	RF	154	216	60	100

All dimensions in mm

EN 1092-1 - TYPE B1

size	rating	type	dD	d4	L	L(optional)
DN25	PN10-400	B1	29	68	100	60
DN40	PN10-400	B1	43	88	100	60
DN50	PN10-400	B1	55	100	100	60
DN65	PN10-400	B1	70	120	100	60
DN80	PN10-400	B1	83	138	60	60
DN100	PN10-400	B1	107	160	60	100
DN125	PN10-400	B1	127	188	60	100
DN150	PN10-400	B1	154	216	60	100

All dimensions in mm

Badotherm has developed a Diaphragm Seal that can measure pressure with process temperatures up to 600°C. To enable a proper functioning of the Diaphragm Seal at these extreme process temperatures a revolutionary new design and principle is used. The novelty of the design is as such that Badotherm has a “Patent” on the High Temperature Diaphragm Seal (HTDS).

Typical applications for high temperature can be found in chemical process industry, petrochemical industry, and in the thermo-solar industry with molten salt.



STANDARD EXECUTION

DIAPHRAGM AISI 316(L)	BODY AISI 321H	MOUNTING CONNECTION top (axial)	FILLING FLUID BSO-46 / BSO-42 / BSO-02	
FACING RF	FACING TYPE B1	BOLTS M10 –1.4980	MAXIMUM PROCESS TEMPERATURE 600°C	SOLUTION page 118

FLANGED PROCESS CONNECTIONS

ASME B16.5

size	rating	facing	dD
1/2"	cl. 150 – cl. 600	RF	81mm
1"	cl. 150 – cl. 600	RF	81mm
1,5"	cl. 150 – cl. 600	RF	81mm
2"	cl. 150 – cl. 600	RF	81mm
3"	cl. 150 – cl. 600	RF	81mm

EN 1092-1

Size	rating	type	dD
DN15	PN10 – PN63	B1	81mm
DN25	PN10 – PN63	B1	81mm
DN40	PN10 – PN63	B1	81mm
DN50	PN10 – PN63	B1	81mm
DN80	PN10 – PN63	B1	81mm

WORKING PRESSURE BY CLASS

body material	bolts	Max. temp.	cl.150	cl.300	cl.400	cl.600
AISI 321(H)	1.4980	600°C	1.4	20.3	27.0	40.5

Note: maximum working pressure in bar at maximum temperature; maximum temperature with cl. 150 is 538 °C

WETTED PARTS, BODY MATERIALS, AND FACING OPTIONS

diaphragm material	body material	facing (ASME B16.5)	facing type (EN 1092-1)
AISI 316(L)	AISI 321H	RF Ra 3.2-6.3 µm	B1 Ra 3.2-12.5 µm
		RJF Ra <1.6 µm	A Ra 3.2-12.5 µm
		LMF Ra 3.2-6.3 µm	B2 Ra 0.8-3.2 µm
		SMF Ra <3.2 µm	C Ra 0.8-3.2 µm
		FF Ra 3.2-6.3 µm	D Ra 0.8-3.2 µm
		LTF Ra <3.2 µm	E Ra 3.2-12.5 µm
		STF Ra <3.2 µm	F Ra 3.2-12.5 µm
		LGF Ra <3.2 µm	
		SGF Ra <3.2 µm	

REQUIRED CUSTOMER DATA – MANDATORY IN ORDER TO QUOTE / MANUFACTURE

Data	Uom
1. GP or dP Measurement	
2. Nominal Process temperature	°C
3. Nominal Process Pressure	bar
4. Minimal Process Pressure	mbar
5. Maximum Process Pressure	bar
6. Span	mbar
7. Capillary Length	meter

DRAWING AND DIMENSIONS STANDARD EXECUTIONS

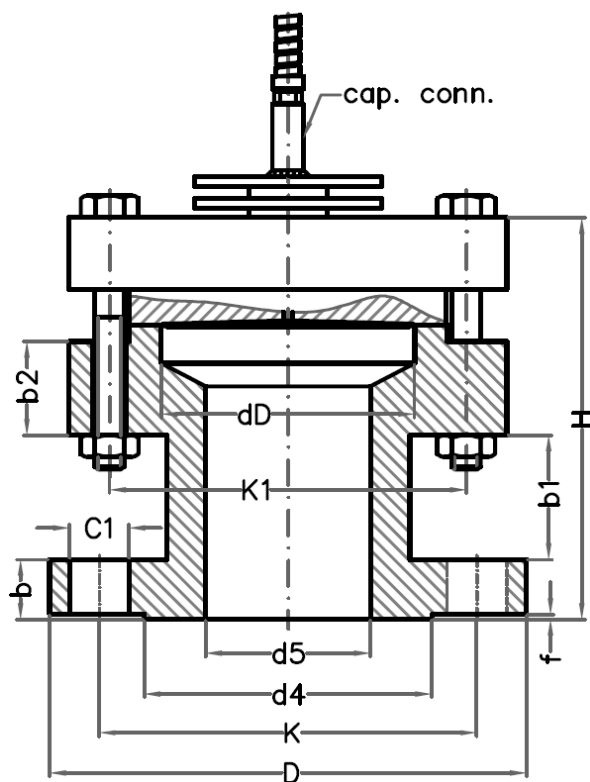

ASME B16.5 - RF FACING

size	rating	facing	dD	d5	D	f	d4	K	K1	b	b1	b2	H	C1 / pcs
1/2"	cl. 150	RF	81	16	90	2	35	60	114	12	60	44	149	1/2" 13 UNC / 4x
1/2"	cl. 300	RF	81	16	95	2	35	67	114	15	60	44	152	1/2" 13 UNC / 4x
1/2"	cl. 400-600	RF	81	16	95	7	35	67	114	21	60	44	158	1/2" 13 UNC / 4x
1"	cl. 150	RF	81	27	110	2	51	79	114	15	60	44	152	1/2" 13 UNC / 4x
1"	cl. 300	RF	81	27	125	2	51	89	114	18	60	44	155	5/8" 11 UNC / 4x
1"	cl. 400-600	RF	81	27	125	7	51	89	114	25	60	44	162	5/8" 11 UNC / 4x
1,5"	cl. 150	RF	81	41	125	2	73	98	114	18	60	44	155	1/2" 13 UNC / 4x
1,5"	cl. 300	RF	81	41	155	2	73	114	114	21	60	44	158	3/4" 10 UNC / 4x
1,5"	cl. 400-600	RF	81	41	155	7	73	114	114	29	60	44	166	3/4" 10 UNC / 4x
2"	cl. 150	RF	81	53	150	2	92	121	114	20	60	44	157	5/8" 11 UNC / 4x
2"	cl. 300	RF	81	53	165	2	92	127	114	23	60	44	160	5/8" 11 UNC / 8x
2"	cl. 400-600	RF	81	53	165	7	92	127	114	32	60	44	169	5/8" 11 UNC / 8x
3"	cl. 150	RF	81	78	190	2	127	152	114	24	60	44	161	5/8" 11 UNC / 4x
3"	cl. 300	RF	81	78	210	2	127	168	114	29	60	44	166	3/4" 10 UNC / 8x
3"	cl. 400-600	RF	81	78	210	7	127	168	114	39	60	44	176	3/4" 10 UNC / 8x

All dimensions in mm

EN 1092-1 - TYPE B1

size	rating	facing	dD	d5	D	f	d4	K	K1	b	b1	b2	H	C1 / pcs
DN15	PN10-40	B1	81	17	95	2	45	65	114	14	60	44	151	M12 / 4x
DN25	PN10-40	B1	81	27	115	2	68	85	114	16	60	44	153	M12 / 4x
DN40	PN10-40	B1	81	41	150	3	88	110	114	18	60	44	155	M16 / 4x
DN50	PN10-40	B1	81	53	165	3	102	125	114	20	60	44	157	M16 / 4x
DN80	PN10-40	B1	81	78	200	3	138	160	114	24	60	44	161	M16 / 4x

All dimensions in mm

DRAWING AND DIMENSIONS RJF FACING

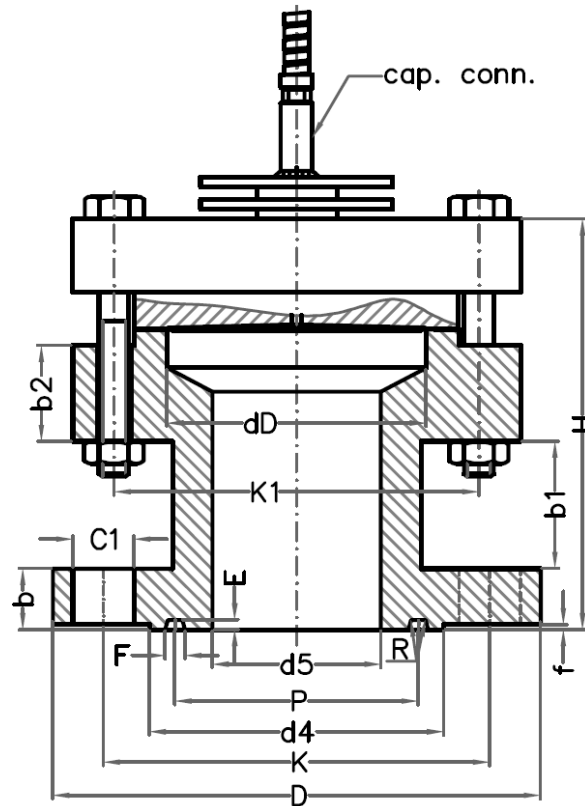

ASME B16.5 - RJF FACING

size	rating	facing	dD	d5	D	f	d4	K	K1	b	b1	b2	H	P	F	E	C1 / pcs	R
1/2"	cl. 300	RJF	81	16	95	6	51	67	114	18	60	44	155	34	7	6	1/2" 13 UNC / 4x	0.8
1/2"	cl. 400-600	RJF	81	16	95	6	51	67	114	20	60	44	157	34	7	6	1/2" 13 UNC / 4x	0.8
1"	cl. 150	RJF	81	27	110	6	64	79	114	19	60	44	156	48	9	6	1/2" 13 UNC / 4x	0.8
1"	cl. 300	RJF	81	27	125	6	70	89	114	22	60	44	159	51	9	6	5/8" 11 UNC / 4x	0.8
1"	cl. 400-600	RJF	81	27	125	6	70	89	114	24	60	44	161	51	9	6	5/8" 11 UNC / 4x	0.8
1,5"	cl. 150	RJF	81	41	125	6	83	98	114	22	60	44	159	65	9	6	1/2" 13 UNC / 4x	0.8
1,5"	cl. 300	RJF	81	41	155	6	91	114	114	25	60	44	162	68	9	6	3/4" 10 UNC / 4x	0.8
1,5"	cl. 400-600	RJF	81	41	155	6	91	114	114	29	60	44	166	68	9	6	3/4" 10 UNC / 4x	0.8
2"	cl. 150	RJF	81	53	150	6	102	121	114	24	60	44	161	83	9	6	5/8" 11 UNC / 4x	0.8
2"	cl. 300	RJF	81	53	165	8	108	127	114	29	60	44	166	83	12	8	5/8" 11 UNC / 8x	0.8
2"	cl. 400-600	RJF	81	53	165	8	108	127	114	33	60	44	170	83	12	8	5/8" 11 UNC / 8x	0.8
3"	cl. 150	RJF	81	78	190	6	133	152	114	29	60	44	166	114	9	6	5/8" 11 UNC / 4x	0.8
3"	cl. 300	RJF	81	78	210	8	146	168	114	35	60	44	172	124	12	8	3/4" 10 UNC / 8x	0.8
3"	cl. 400-600	RJF	81	78	210	8	146	168	114	40	60	44	177	124	12	8	3/4" 10 UNC / 8x	0.8

All dimensions in mm

Badotherm Hub seal is a special design based on high pressure clamp so called hub connectors such as Destec® or Galperti®. These type of connectors are designed for high pressure applications (>400 bar) where standard flanges cannot be used or only with extreme heavy weight, since another advantage of the Hub connector is the relative small design with a far lower load on the process installation. BHS seals can be used for either pressure measurement or differential pressure measurement (level, flow) where high static pressure occurs. The BHS can be produced with an internal diaphragm (smaller hub sizes) or a flush diaphragm (larger hub sizes), this depends on the specific application.



STANDARD EXECUTION

DIAPHRAGM	BODY	MOUNTING CONNECTION
AISI 316(L)	AISI 316(L)	top (axial)

FLANGED PROCESS CONNECTIONS

DESTEC®

size	G-Range	MWP ³	facing	dD
½" schedule 40-80	G1-5 ¹	1100 bar	seal ring	32mm
2" schedule XXS	G2-14	586 bar	seal ring	32mm
2 ½" schedule 40-80	G3-25	486 bar	seal ring	44mm
4"	G4-27	708 bar	seal ring	57mm

1: G1-5 is executed with reducer; 2: other sizes possible; 3 :at -46 to 20°C based on PT table G-range Destec

WETTED PARTS, BODY MATERIALS, AND FACING OPTIONS

diaphragm material	body material
AISI 316(L)	AISI 316(L)
AISI 304(L)	
AISI 321	
Hastelloy C-276	
Monel 400	Monel 400
Hastelloy C-276	Hastelloy C-276
Duplex 2205	Super Duplex / Duplex

COATING AND OTHER OPTIONS

COATINGS

- gold: 25 µm / 40 µm chemical resistance and/or hydrogen permeation protection (facing and/or diaphragm – page 120)

OTHER OPTIONS

- heavy duty capillary tube
- TR - temperature reducer
- clamps and gaskets
- other brands

page 113/123
page 114

DRAWING AND DIMENSIONS STANDARD EXECUTIONS

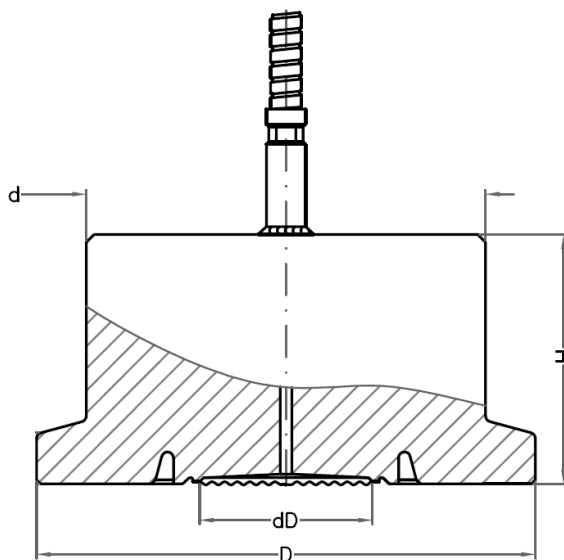

DESTEC®

size	rating	facing	dD	d	D	H
G1-5¹	1100 bar	seal ring	32	47	51	44
G2-14	586 bar	seal ring	32	73	92	51
G3-25	486 bar	seal ring	44	102	127	64
G4-27	708 bar	seal ring	57	127	152	64

¹with reducing hub
All dimensions in mm

SJ is typically used in combination with pressure transmitters for pressure measurement, in those applications where the diaphragm need to be flush with the pipe wall. This can be obtained by either mounting the SJ seal part in a saddle type that is welded on top of the piping or in a flow through block that can be welded into the piping or mounted by means of flanges. Typical applications are pressure and flow measurements of highly viscous media.



STANDARD EXECUTION

DIAPHRAGM	BODY	MOUNTING CONNECTION	GASKET
AISI 316(L)	AISI 316(L)	top (axial)	PTFE

PROCESS CONNECTIONS

SADDLE TYPE, WELDED

size	rating	dD
2,5"- 24"	cl. 300	51mm
DN65-600	PN10-40	51mm

FLOW THROUGH BLOCK, BUTT OR SOCKET WELD

size	rating	dD
3/8"- 2"	cl. 300	51mm
DN15-50	PN10-40	51mm

UPPER AND LOWER PART ASSEMBLY

BOLTING

thread	material	mwp	pcs	rating (ASME)	rating (EN)
M8	A2-70	40 bar	8	cl. 300	PN40

Note: mwp (maximum working pressure) at 20 °C with AISI 316(L) body material

GASKET

material	
Virgin PTFE	-200 / +260°C
Garfite N	73 / +343°C

WETTED PARTS AND BODY MATERIAL

diaphragm mat.	body material	saddle / block material
AISI 316(L)	AISI 316(L)	AISI 316(L)
AISI 304(L)		
AISI 321		
Hastelloy C-276		
Hastelloy C-276	AISI 316(L)	Hastelloy C-276
Monel 400	AISI 316(L)	Monel 400
Tantalum	AISI 316(L)	AISI 316(L)
Nickel 201	AISI 316(L)	Nickel 201
Duplex 2205	AISI 316(L)	Duplex
Inconel 600	AISI 316(L)	Inconel 600
Titanium Gr.1	Titanium Gr.2	Titanium Gr.2

COATING AND OTHER OPTIONS

COATINGS

- gold: 25 µm / 40 µm chemical resistance and/or hydrogen permeation protection (facing and/or diaphragm – page 120)
- PTFE / ECTFE for anti stick purpose only (upper part)
- FEP / PFE (upper part)
- Tantaline wetted parts

OTHER OPTIONS

- heavy duty capillary tube
- TR - temperature reducer

page 113/123

page 114

DRAWING AND DIMENSIONS STANDARD EXECUTIONS

UPPER PART (SJ)

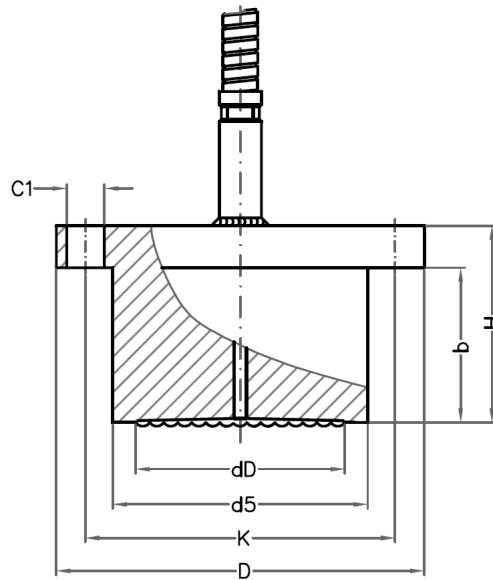

size	rating	D	dD	d5	K	b	H	C1
std	PN 40	88	50	61	74	37	47	8x9mm

All dimensions in mm

SOCKET WELD (SJ-IS)

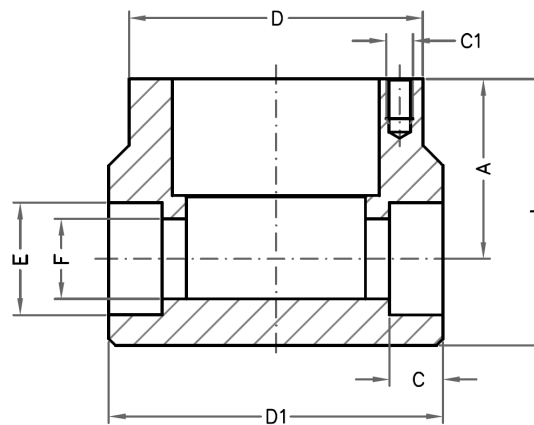

Size	D	D1	E	F	C	A	I	C1
0,5" (DN15)	88	95	22	16	13	48	65	M8/8x
0,75" (DN20)	88	95	27	21	13	50	70	M8/8x
1" (DN25)	88	100	34	27	16	54	80	M8/8x
1,5" (DN40)	88	100	49	41	18	61	95	M8/8x
2" (DN50)	88	100	61	53	21	67	105	M8/8x

All dimensions in mm

BUTT WELD (SJ-IB)

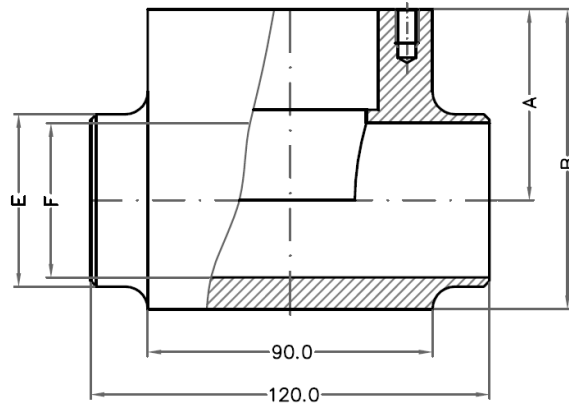

size	E	F ⁽¹⁾ (S10)	F (S40)	A	B	C1
0,5" (DN15)	21	17	16	48	69	M8/8x
0,75" (DN20)	27	22	21	50	74	M8/8x
1" (DN25)	33	28	27	54	81	M8/8x
1,5" (DN40)	48	43	41	61	95	M8/8x
2" (DN50)	60	57	55	67	107	M8/8x

¹ dimensions for EN - piping
All dimensions in mm

SADDLE (SJ-S)

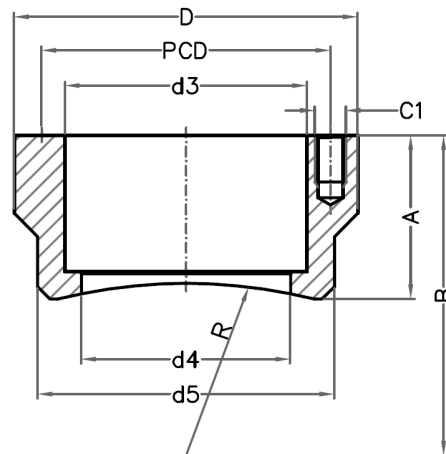

size	A	B	d3	d4	d5	R	C1	PCD
2" DN50	50	38	62	38	64	31	M8/8x	74
2,5" DN65	50	77	62	54	76	37	M8/8x	74
3" DN80	50	83	62	54	76	45	M8/8x	74
4" DN100	47	95	62	54	76	57	M8/8x	74
5" DN125	46	109	62	54	76	71	M8/8x	74
6" DN150	44	122	62	54	76	84	M8/8x	74
8" DN200	43	148	62	54	76	110	M8/8x	74
10" DN250	42	175	62	54	76	137	M8/8x	74
12" DN300	41	200	62	54	76	162	M8/8x	74
14" DN350	41	216	62	54	76	178	M8/8x	74
16" DN400	41	241	62	54	76	203	M8/8x	74
18" DN450	41	267	62	54	76	229	M8/8x	74
20" DN500	40	292	62	54	76	254	M8/8x	74
22" DN550	40	317	62	54	76	279	M8/8x	74
24" DN600	40	343	62	54	76	305	M8/8x	74

All dimensions in mm

The BHP construction is designed for those applications where the process pressure is very high. The construction is executed with a stainless steel sensing element welded in bar stock material which is designed to withstand these high pressures.



STANDARD EXECUTION

SENSING ELEMENT	BODY	MOUNTING CONNECTION
AISI 316(L)	AISI 316(L)	top (axial)

THREADED PROCESS CONNECTIONS

INSTRUMENT CONNECTION

Size		mwp
9/16" -18UNF	Female	4000 bar
M16 x 1.5	Female	4000 bar
5/8" - 18UNF	Female	4000 bar

Note: mwp (maximum working pressure) at 20 °C with 316L body material

PROCESS CONNECTION

size		mwp
9/16" -18UNF	Female	4000 bar
M16 x 1.5	Female	4000 bar
5/8" - 18UNF	Female	4000 bar

Note: mwp at 20 °C with 316L body material

threads	norms
UNF	ANSI 131.1
METRIC	ISO 965

DRAWING AND DIMENSIONS STANDARD EXECUTION

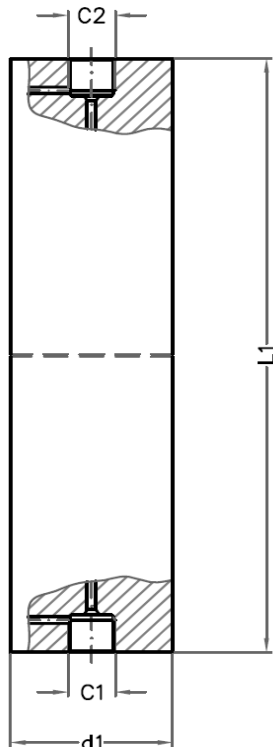

C2	C1	d1	L1
9/16" -18UNF	9/16" -18UNF	45	265
9/16" -18UNF	M16 x 1.5	45	265
9/16" -18UNF	5/8" - 18UNF	45	265

All dimensions in mm

The selection of a fill fluid for a diaphragm seal application requires a careful review of the application conditions. The fill fluid characteristics determine to a large extent the diaphragm seal system performance in terms of response time and temperature effect. Several fill fluid characteristics need to be taken into account to make the appropriate selection of the fill fluid.

At first the **type of fill fluid** is important as it should be compatible with the process medium. The most commonly used are Silicone or Inert based fluids, but also other specific types are used; all with specifications and characteristics to match different conditions. The **operating temperature** of the fill fluid is the second im-

portant factor for selection. The application temperature should remain between the limits to guarantee proper functioning of the application. All fill fluids expand or contract with changes in temperature and this is referred to as the diaphragm seal temperature effect. The fluid **viscosity and density** have an effect on the response time of the application. A more viscous fill fluid will result in a longer response time and a fill fluid with a higher density will have an increased mounting effect. The **vapour pressure** curve shows if the selected fill fluid is suitable for the minimal process pressures in combination with the desired process temperatures. This is especially important for vacuum applications.

SPECIFICATIONS

name	type	operating temperature (°C)	viscosity (cSt)	density (kg/dm ³)	
BSO-02	Silicone	-40/+400	9.85	0.93	
BSO-03	Inert	-80/+100	2.4	1.84	
BSO-06	Inert	0/+200	40.0	1.92	
BSO-18	Silicone	-10/+315	38.0	1.07	
BSO-20	Silicone	+20/+350	175.0	1.09	
BSO-21	Silicone	-40/+315	125.0	1.07	
BSO-22	Silicone	-50/+200	20.0	0.95	
BSO-25	Inert	-40/+250	31.5	1.87	
BSO-36	Silicone	-70/+150	10.0	0.93	
BSO-40	Polyol diester	-15/+225	9.5	0.92	FDA approved
BSO-41	Silicone	-80/+120	5.0	0.92	
BSO-42	Silicone	-20/+350	57.6	1.07	
BSO-45	Hydrogenerated mineral oil	-40/+250	9.8	0.83	FDA 21 GRF
BSO-46	Hydrogenated terphenyl	-5/+345	29.6	1.01	
BSO-48	Silicone	-20/+410	57.6	1.08	

OPERATING TEMPERATURE GRAPH (°C)

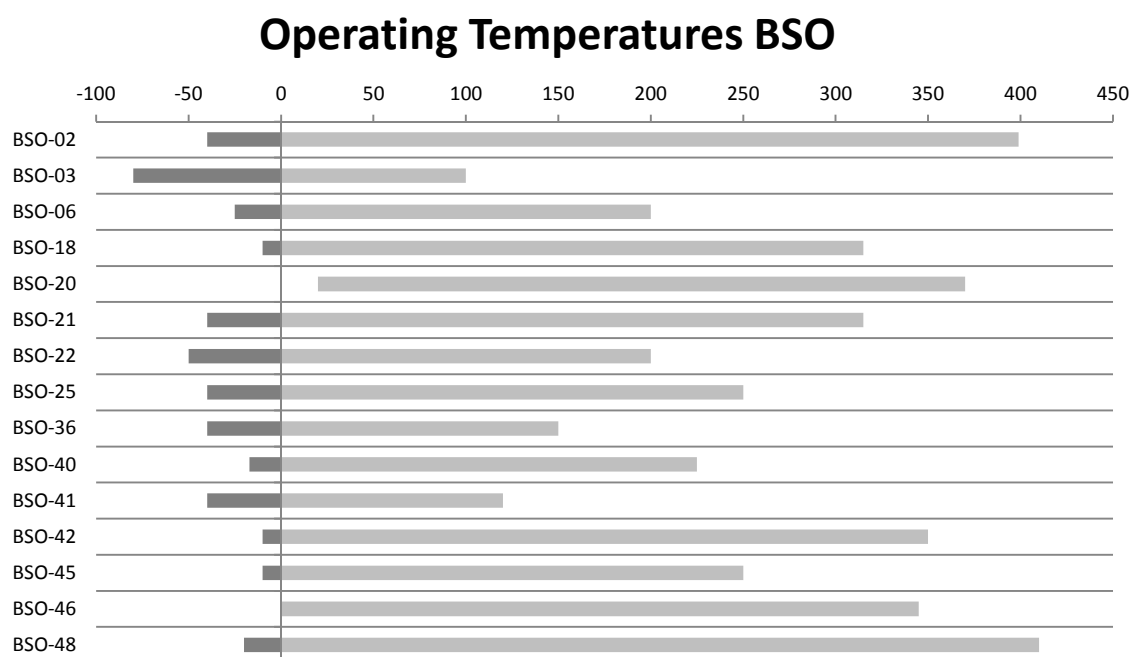

BSO-02 is a silicone fill fluid designed for high temperature applications. Its vapour pressures are relatively elevated at higher temperatures and its low viscosity results in excellent performance with regard to response times.

- For high temperature applications
- This fluid is not approved for food or pharmaceutical applications

SPECIFICATIONS

OPERATING TEMPERATURE -40/+400°C	DESIGN TEMPERATURE +400°C	FREEZING POINT TEMPERATURE -40°C
TYPE Silicone	VISCOSITY 9.8 cSt	DENSITY 0.93 kg/dm ³

Note: viscosity and density at 25°C

VAPOUR PRESSURE RESULTS

BSO-02

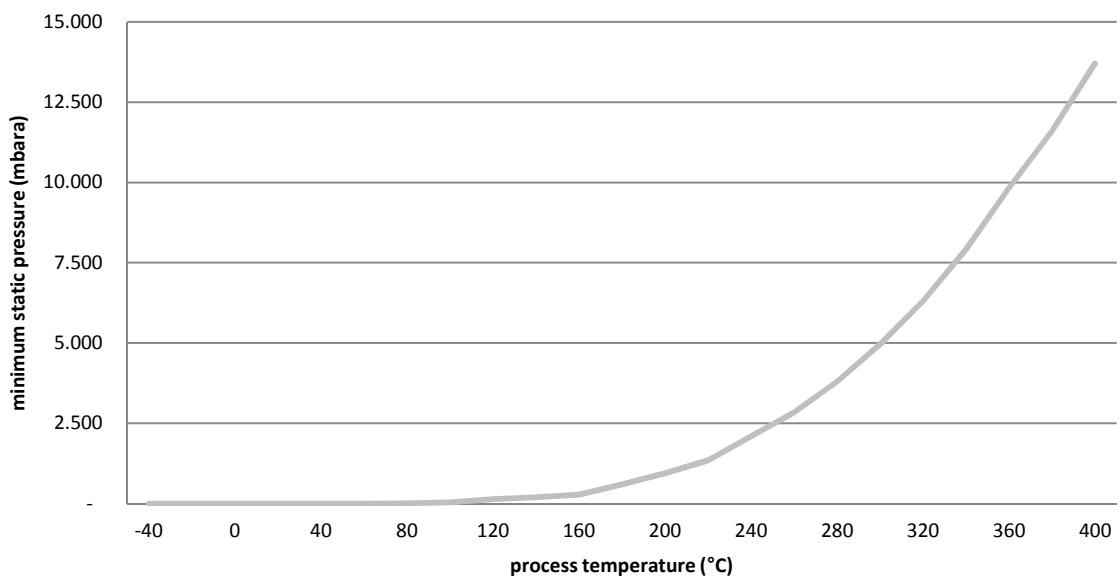

BSO-03 is an inert CTFE fill fluid. Its very low viscosity allows for excellent response times. This fluid has a reported freezing point of -93°C, but the temperature limit is set at a higher temperature to allow the Diaphragm Seal System to function properly.

- Typically used for low temperature applications
- Used in silicon free environments
- Can be used for chlorine and oxygen applications
- Can be used as secondary fill for Temperature Compensator
- This fluid is not approved for food or pharmaceutical applications

SPECIFICATIONS

OPERATING TEMPERATURE	DESIGN TEMPERATURE	FREEZING POINT TEMPERATURE
-80/+100 °C	+100°C	-93°C
TYPE	VISCOSITY	DENSITY
Inert	2.4 cSt	1.84 kg/dm ³

Note: viscosity and density at 25°C

VAPOUR PRESSURE RESULTS

BSO-03

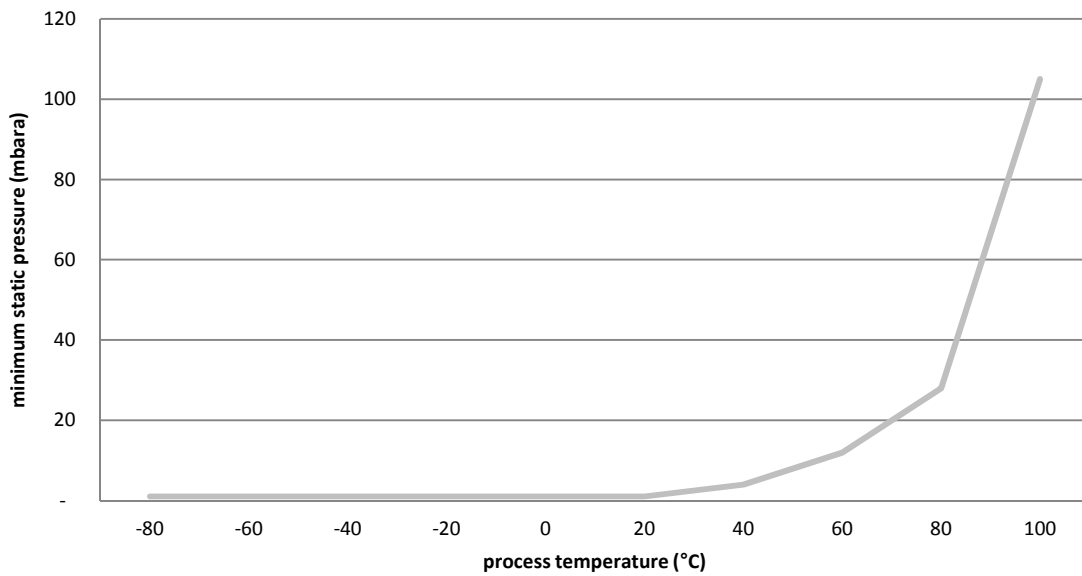

BSO-06 is an inert CTFE fill fluid. This fluid has a reported freezing point of -40°C, but the temperature limit is set at a higher temperature to allow the Diaphragm Seal System to function properly.

- Typically used in silicon free environments
- Can be used for chlorine and oxygen applications
- This fluid is not approved for food or pharmaceutical applications

SPECIFICATIONS

OPERATING TEMPERATURE	DESIGN TEMPERATURE	FREEZING POINT TEMPERATURE
0/+200 °C	+200°C	-40°C
TYPE	VISCOSITY	DENSITY
Inert	40.0 cSt	1.92 kg/dm ³

Note: viscosity and density at 25°C

VAPOUR PRESSURE RESULTS

BSO-06

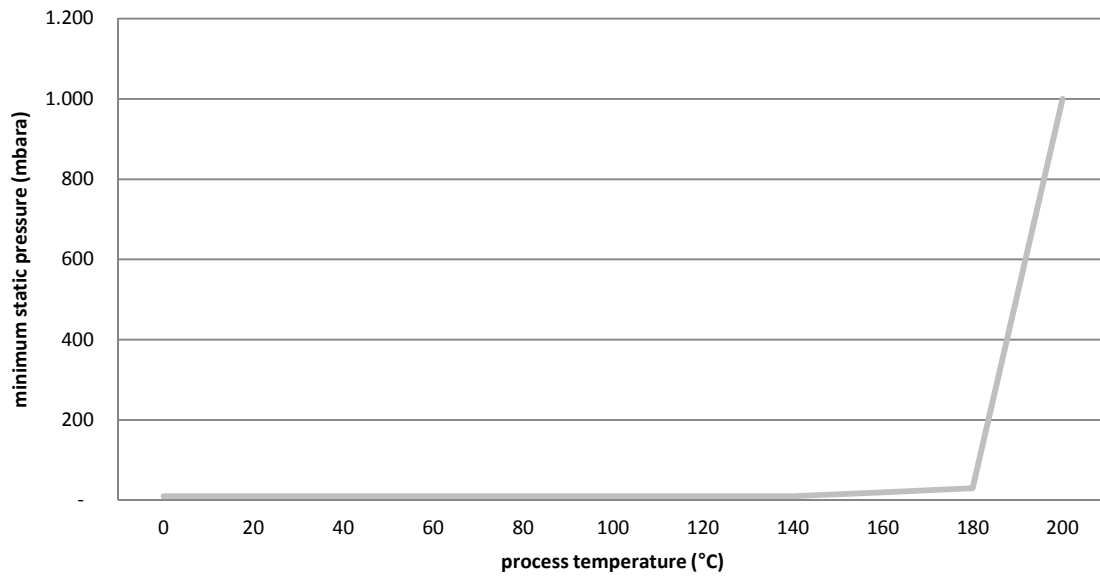

BSO-18 is a silicone fill fluid designed as a fluid for diffusion pumps for applications where high vacuum in combination with elevated temperatures are present. In cold outdoor applications its relative high viscosity might result in long response times. Under those conditions, heat tracing and/or insulation of capillaries is recommended or a temperature compensator can be applied.

- Typically used for applications with high vacuum in combination with high temperatures
- This fluid is not approved for food or pharmaceutical applications

SPECIFICATIONS

OPERATING TEMPERATURE	DESIGN TEMPERATURE	FREEZING POINT TEMPERATURE
-10/+315 °C	+315°C	-10°C
TYPE	VISCOSITY	DENSITY
Silicone	38.0 cSt	1.07 kg/dm ³

Note: viscosity and density at 25°C

VAPOUR PRESSURE RESULTS

BSO-18

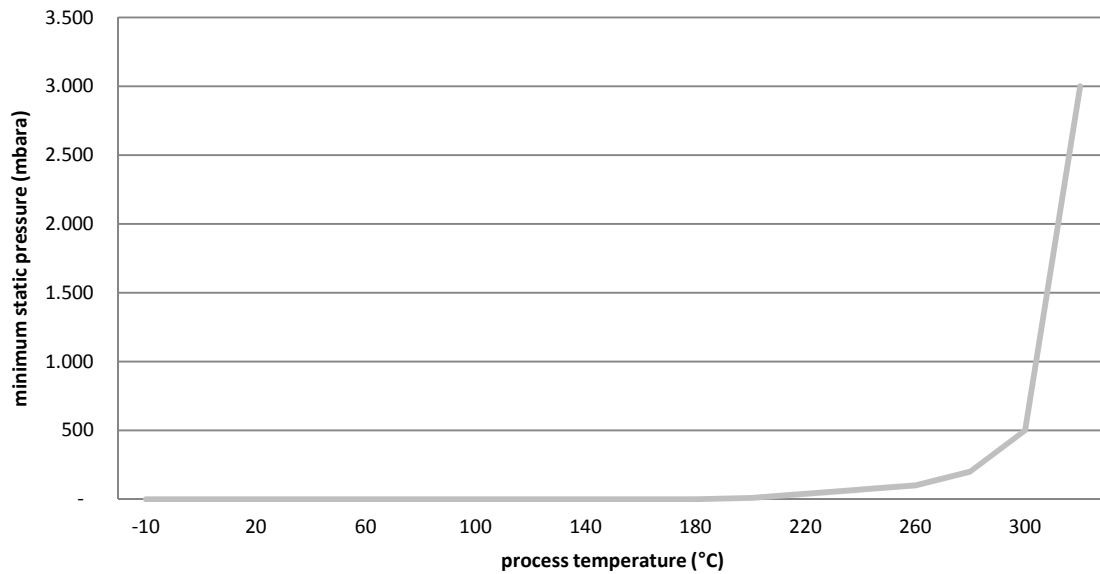

BSO-20 is a silicone fill fluid designed as a fluid for applications where high vacuum in combination with elevated temperatures are present. The freezing point of this fill fluid is at +20°C, thus not recommended for cold outdoor applications. Under these conditions, heat tracing and/or insulation of capillaries is recommended, or a temperature compensator can be applied. Its high viscosity may result in long response times. Due to its high viscosity it is not recommended using 1mm ID capillary.

- Typically for applications where high vacuum in combination with high temperatures
- This fluid is not approved for food or pharmaceutical applications

SPECIFICATIONS

OPERATING TEMPERATURE	DESIGN TEMPERATURE	FREEZING POINT TEMPERATURE
+20/+350 °C	+400°C	+20°C
TYPE	VISCOSITY	DENSITY
Silicone	175.0 cSt	1.09 kg/dm ³

Note: viscosity and density at 25°C

VAPOUR PRESSURE RESULTS

BSO-20

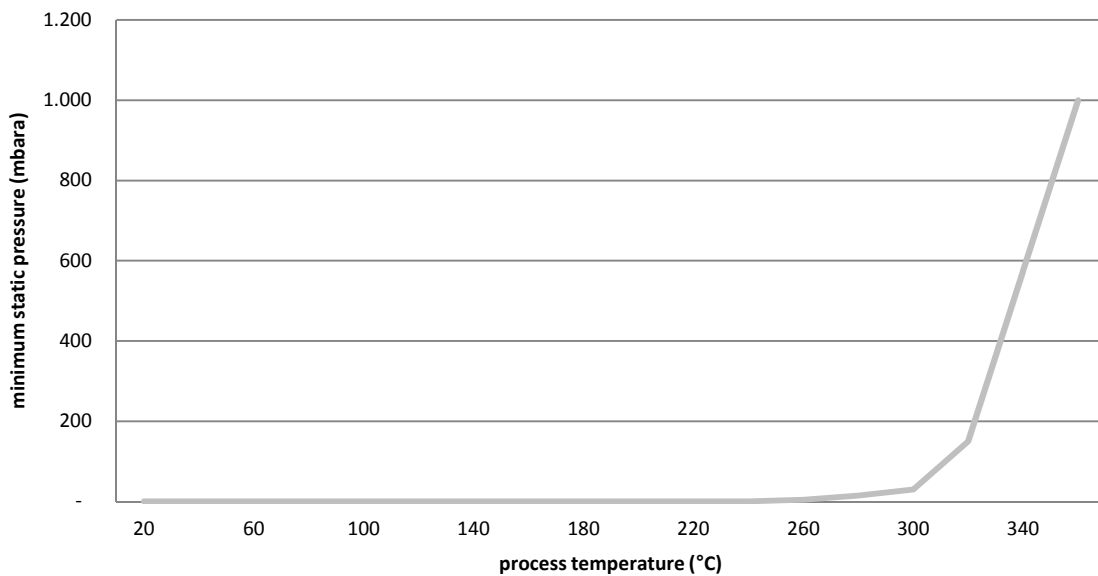

BSO-21 is a silicone fill fluid designed for applications where high vacuum in combination with elevated temperatures are present. Major difference with the BSO-20 is that it is better suitable for lower process temperatures. Due to its high viscosity it is not recommended using 1mm ID capillary.

- Typically for applications where high vacuum in combination with elevated temperatures are present
- This fluid is not approved for food or pharmaceutical applications

SPECIFICATIONS

OPERATING TEMPERATURE	DESIGN TEMPERATURE	FREEZING POINT TEMPERATURE
-40/+315 °C	+315°C	-50°C
TYPE	VISCOSITY	DENSITY
Silicone	125.0 cSt	1.07 kg/dm ³

Note: viscosity and density at 25°C

VAPOUR PRESSURE RESULTS

BSO-21

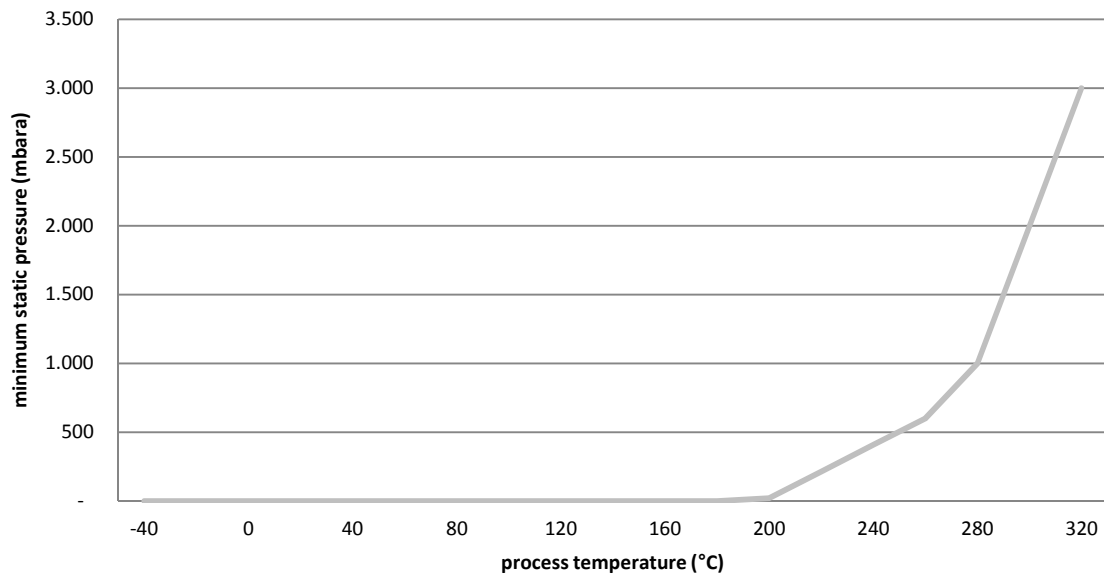

BSO-22 is the standard silicone fill fluid. It has a good balance of all the different specifications and is therefore used in more than half of the diaphragm seal applications. It has a maximum temperature of 200 °C and its freezing point exceeds the temperature range for proper functioning of the diaphragm seal system.

- The standard silicone fill fluid
- This fluid is not approved for food or pharmaceutical applications

SPECIFICATIONS

OPERATING TEMPERATURE	DESIGN TEMPERATURE	FREEZING POINT TEMPERATURE
-50/+200 °C	+204°C	-84°C
TYPE	VISCOSITY	DENSITY
Silicone	20.0 cSt	0.95 kg/dm ³

Note: viscosity and density at 25°C

VAPOUR PRESSURE RESULTS

BSO-22

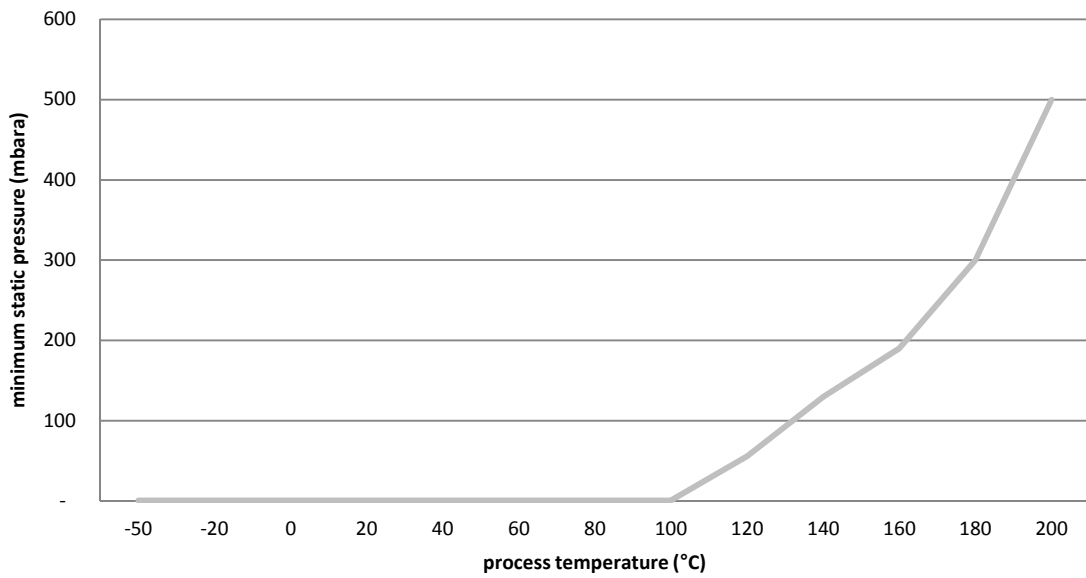

BSO-25 is an inert CTFE filling fluid that is typically used for chlorine and oxygen applications. The design temperature exceeds the temperature limits for proper functioning of the diaphragm seal system.

- Typically used for chlorine and oxygen applications
- Used in silicon free environments
- This fluid is not approved for food or pharmaceutical applications

SPECIFICATIONS

OPERATING TEMPERATURE	DESIGN TEMPERATURE	FREEZING POINT TEMPERATURE
-40/+250 °C	+300°C	-40°C
TYPE	VISCOSITY	DENSITY
Inert	31.5 cSt	1.87 kg/dm ³

Note: viscosity and density at 25°C

VAPOUR PRESSURE RESULTS

BSO-25

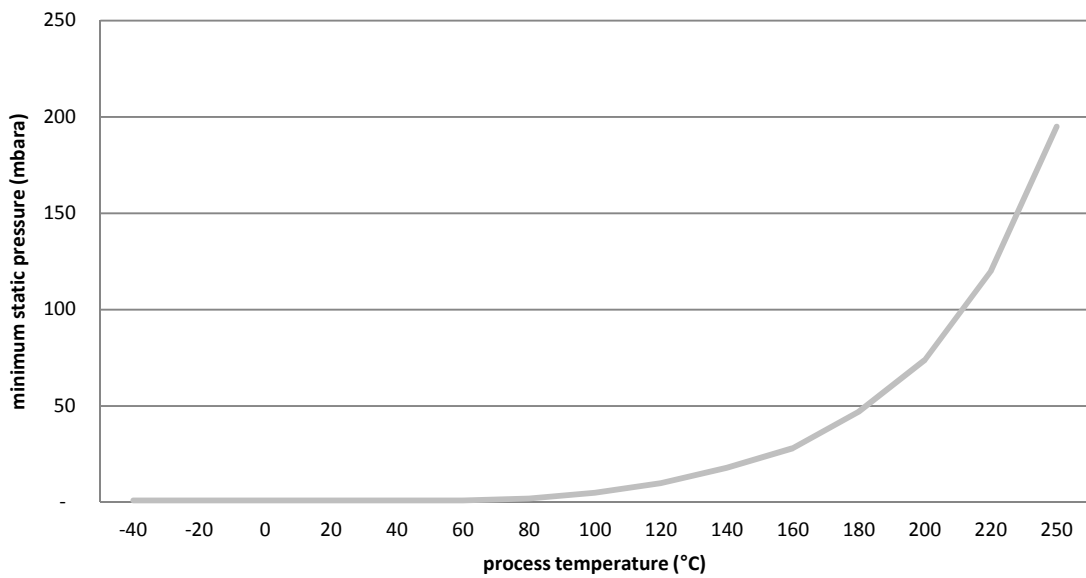

BSO-36 is a silicone fill fluid and because of its low viscosity can be considered as a substitute of BSO-22 in the rare cases where the latter cannot meet the response time requirements. The maximum temperature is of 150°C.

- Typically used for cold process temperatures
- This fluid is not approved for food or pharmaceutical applications

SPECIFICATIONS

OPERATING TEMPERATURE	DESIGN TEMPERATURE	FREEZING POINT TEMPERATURE
-70/+150 °C	+150°C	-70°C
TYPE	VISCOSITY	DENSITY
Silicone	10.0 cSt	0.93 kg/dm ³

Note: viscosity and density at 25°C

VAPOUR PRESSURE RESULTS

BSO-36

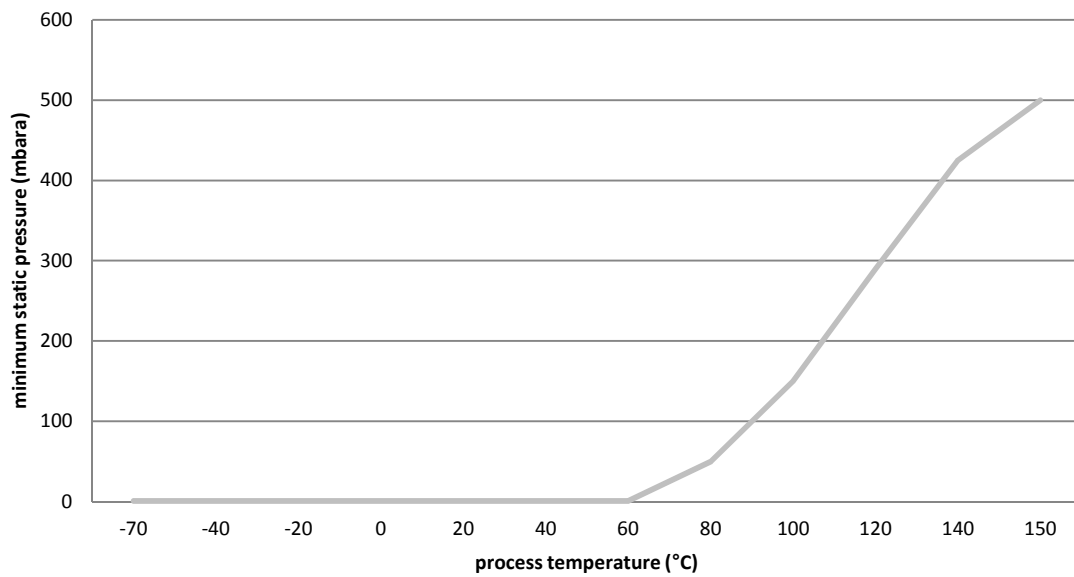

BSO-40 is the standard fill fluid for food and pharmaceutical applications. It has FDA approvals 21CFR 172.856 as direct and 21CFR 174.5 as indirect food additive. Its CAS registration number is 68583-51-7. It is a derivate of coconut oil and propylene glycol.

- This fluid is approved for food or pharmaceutical applications
- FDA approvals 21CFR 172.856 and 21CFR 174.5
- CAS registration number is 68583-51-7

SPECIFICATIONS

OPERATING TEMPERATURE	DESIGN TEMPERATURE	FREEZING POINT TEMPERATURE
-15/+225 °C	+225°C	-19°C
TYPE	VISCOSITY	DENSITY
Polyol diester	9.5 cSt	0.92 kg/dm ³

Note: viscosity and density at 25°C

VAPOUR PRESSURE RESULTS

BSO-40

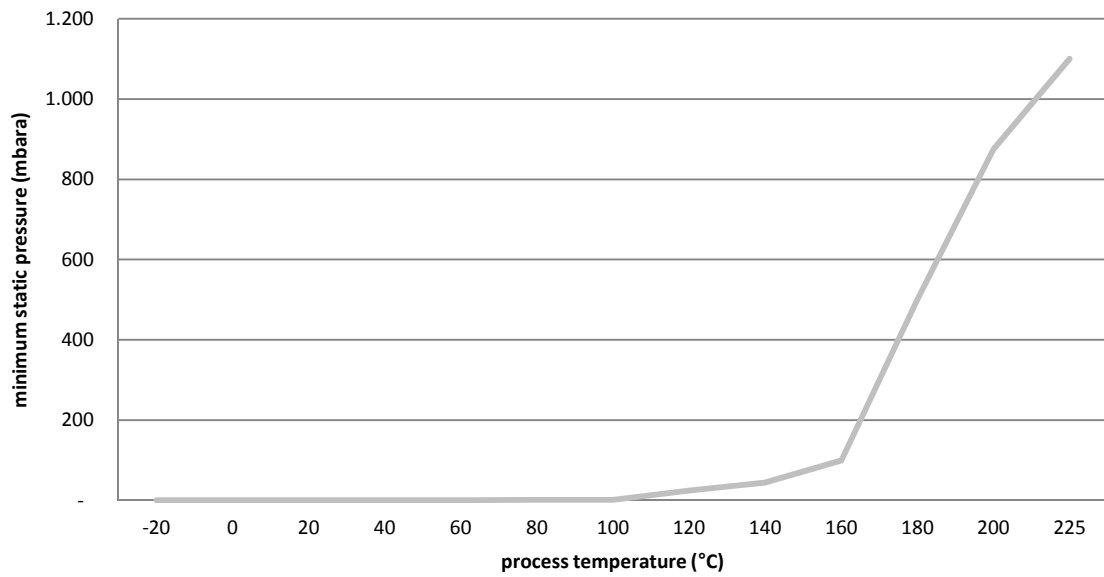

BSO-41 is a silicone fill fluid and because of its very low viscosity should be considered as a replacement of BSO-22 in the rare cases where the latter cannot meet the response time requirements. It is considered as an excellent second fill for temperature compensator applications.

- Used as secondary fill for Temperature Compensator
- This fluid is not approved for food or pharmaceutical applications

SPECIFICATIONS

OPERATING TEMPERATURE -80/+120 °C	DESIGN TEMPERATURE +120°C	FREEZING POINT TEMPERATURE -80°C
TYPE Silicone	VISCOSITY 5.0 cSt	DENSITY 0.92 kg/dm ³

Note: viscosity and density at 25°C

VAPOUR PRESSURE RESULTS

BSO-41

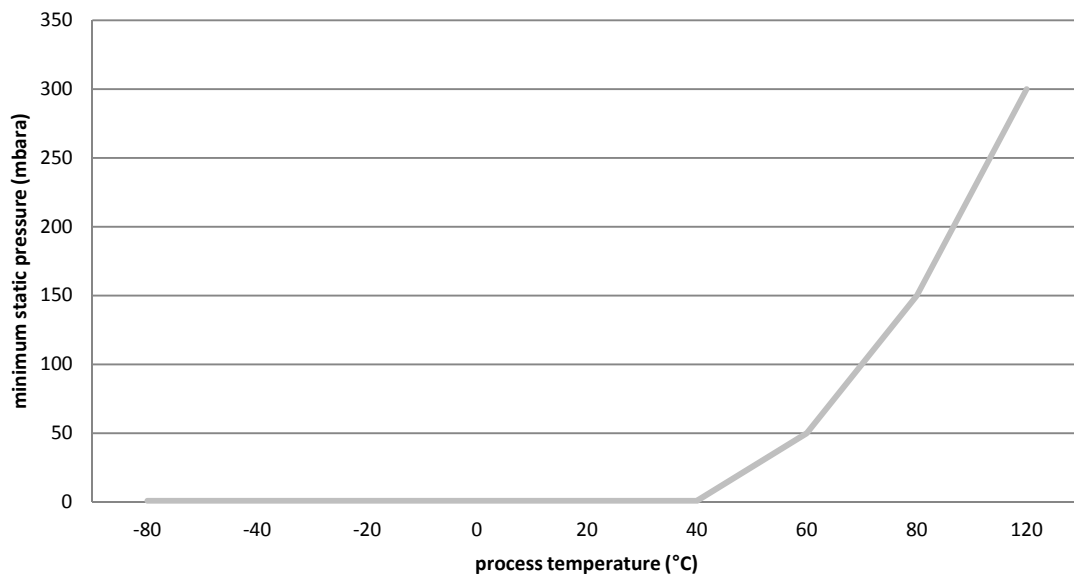

BSO-42 is a Badotherm developed blend of silicone fill fluids. It has the same maximum temperature as BSO-20 but far lower freezing point and lower viscosity resulting in better response time performance than BSO-20. As such it is the standard fill fluid for high temperature applications.

- Typically for high temperature applications
- This fluid is not approved for food or pharmaceutical applications

SPECIFICATIONS

OPERATING TEMPERATURE -20/+350 °C	DESIGN TEMPERATURE +400°C	FREEZING POINT TEMPERATURE -20°C
TYPE Silicone	VISCOSITY 57.6 cSt	DENSITY 1.07 kg/dm ³

Note: viscosity and density at 25°C

VAPOUR PRESSURE RESULTS

BSO-42

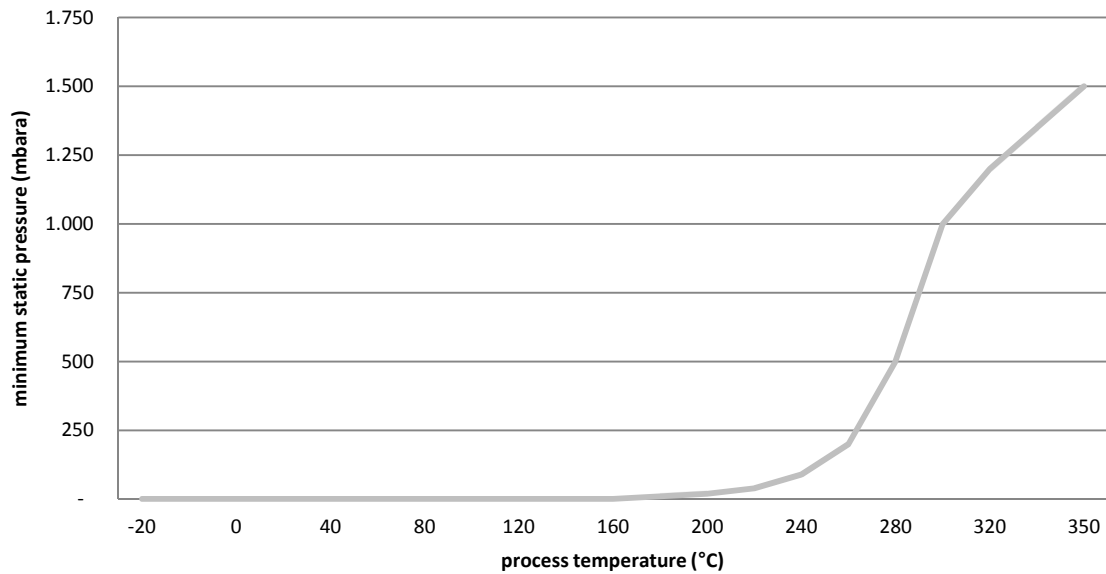

BSO-45 is a lubricant preparation and is especially developed for processes that require both cooling and heating. It is also recommended for use in food processing plants. This fluid meets the requirement established by the FDA at 21 CFR 178.3620(b).

- This fluid is approved for food or pharmaceutical applications
- FDA approvals 21CFR 178.3620(b)

SPECIFICATIONS

OPERATING TEMPERATURE	DESIGN TEMPERATURE	FREEZING POINT TEMPERATURE
-40/+250 °C	+250°C	-48°C
TYPE	VISCOSITY	DENSITY
Hydrogenerated mineral oil	9.8 cSt	0.83 kg/dm ³

Note: viscosity and density at 25°C

VAPOUR PRESSURE RESULTS

BSO-45

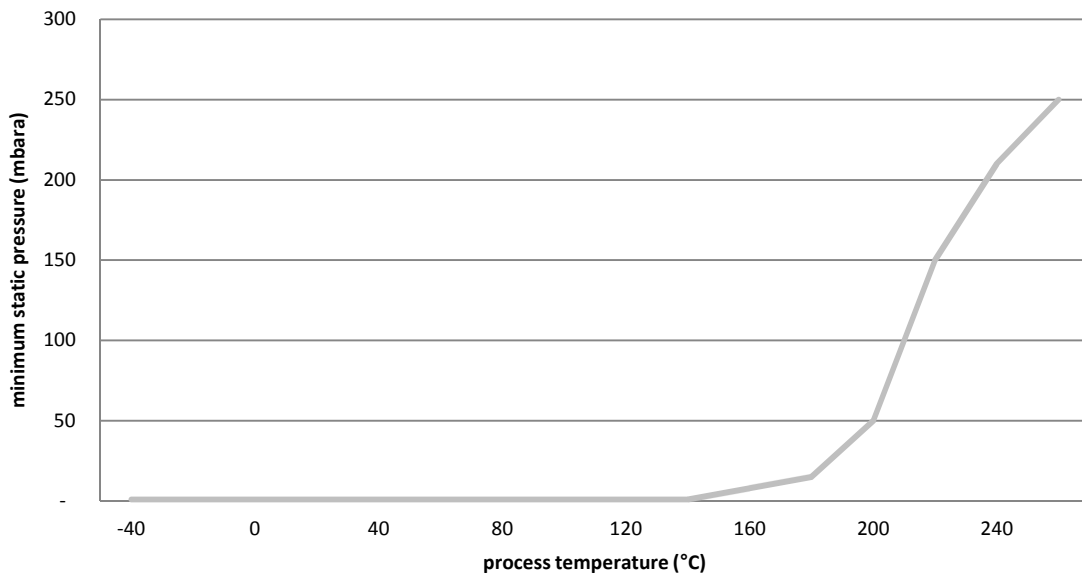

BSO-46 is a high performance, highly stable synthetic heat transfer fluid. Its freezing point exceeds the temperature range limits for proper functioning. A specific feature of this fill fluid is that it is self-restoring, meaning that even when its design temperature is exceeded, the fill fluid specifications remain intact after cooling down.

- This fluid is not approved for food or pharmaceutical applications

SPECIFICATIONS

OPERATING TEMPERATURE -5/+345°C	DESIGN TEMPERATURE +345°C	FREEZING POINT TEMPERATURE -32°C
TYPE Hydrogenated terphenyl	VISCOSITY 29.6 cSt	DENSITY 1.01 kg/dm ³

Note: viscosity and density at 25°C

VAPOUR PRESSURE RESULTS

BSO-46

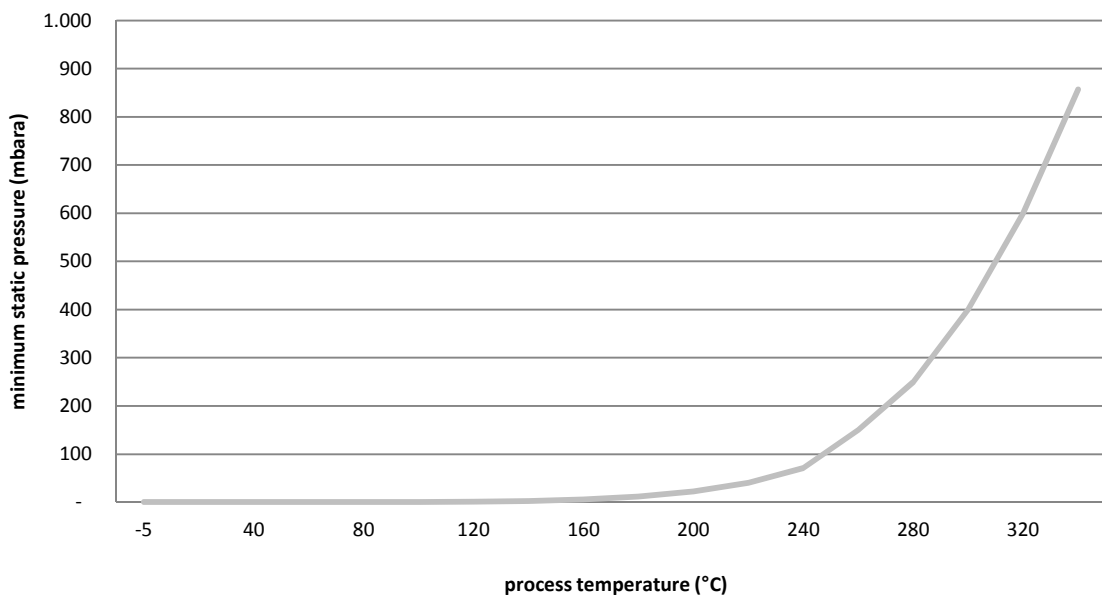

BSO-48 is a Badotherm designed blend of silicone fill fluids. It has better temperature specification than the BSO-42 (another Badotherm blend) especially a better performance at low pressure (high vacuum) combined with high operating temperatures. As such it is an appropriate fill fluid for the boundaries of high temperature applications.

- Typically for high temperature applications
- This fluid is not approved for food or pharmaceutical applications

SPECIFICATIONS

OPERATING TEMPERATURE -20/+410°C	DESIGN TEMPERATURE +420°C	FREEZING POINT TEMPERATURE -32°C
TYPE Silicone	VISCOSITY 57.6 cSt	DENSITY 1.08 kg/dm ³

Note: viscosity and density at 25°C

VAPOUR PRESSURE RESULTS

BSO-48

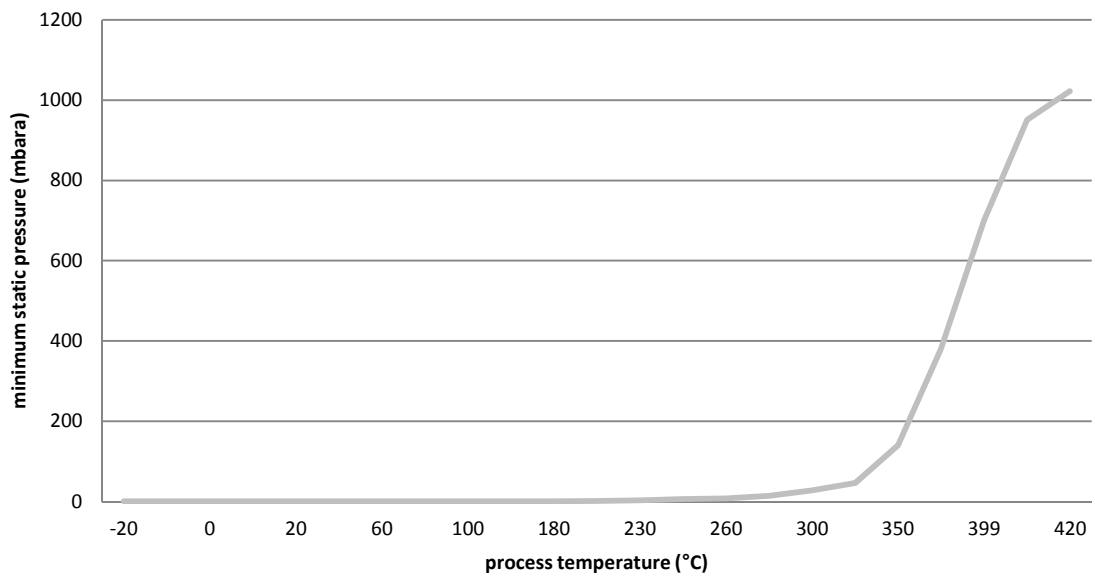

Flushing flange is used for flushing solution combined with diaphragm seals. This type of flushing ring is clamped between process nozzle and diaphragm seal and aligned by the exact same bolt holes as the process nozzle and the diaphragm seal. The flushing flange can be combined with the BF and BRf seal and BC and BRC seal.



STANDARD EXECUTION

BODY	GASKET SURFACE FINISH	FACING	TYPE
AISI 316(L)	Ra 3.2-6.3 μm	RF	type B1

FLUSH CONNECTION

1/4" NPT

FLANGED PROCESS CONNECTIONS

ASME B16.5

size	rating
1"	cl. 150 - cl. 2500
1.5"	cl. 150 - cl. 2500
2"	cl. 150 - cl. 2500
3"	cl. 150 - cl. 2500
4"	cl. 150 - cl. 2500

EN 1092-1

size	rating
DN25	PN10-100
DN40	PN10-100
DN50	PN10-100
DN80	PN10-100
DN100	PN10-100

FLUSHING CONNECTIONS

size	thread	norms
1/4"	NPT	ANSI B1.20.1
1/4"	BSP	ISO 228
1/2"	NPT	ANSI B1.20.1
1/2"	BSP	ISO 228

BODY MATERIAL, AND FACING OPTIONS

body material
AISI 316(L)
AISI 304(L)
AISI 321
Hastelloy C-276
Monel 400
Duplex
Super Duplex
Inconel 600

facing (ASME B16.5)	
RF	Ra 3.2-6.3 μm
RJF	Ra <1.6 μm
LMF	Ra 3.2-6.3 μm
SMF	Ra <3.2 μm
FF	Ra 3.2-6.3 μm
LTF	Ra <3.2 μm
STF	Ra <3.2 μm
LGF	Ra <3.2 μm
SGF	Ra <3.2 μm
LFF	Ra 3.2-6.3 μm
SFF	Ra <3.2 μm

facing type (EN 1092-1)	
B1	Ra 3.2-12.5 μm
A	Ra 3.2-12.5 μm
B2	Ra 0.8-3.2 μm
C	Ra 0.8-3.2 μm
D	Ra 0.8-3.2 μm
E	Ra 3.2-12.5 μm
F	Ra 3.2-12.5 μm
G	Ra 0.8-3.2 μm
H	Ra 0.8-3.2 μm

OPTIONS

- vent & blind plugs
- BDTV 910 valves
- set of handles welded on side of flange

DRAWING AND DIMENSIONS STANDARD EXECUTIONS

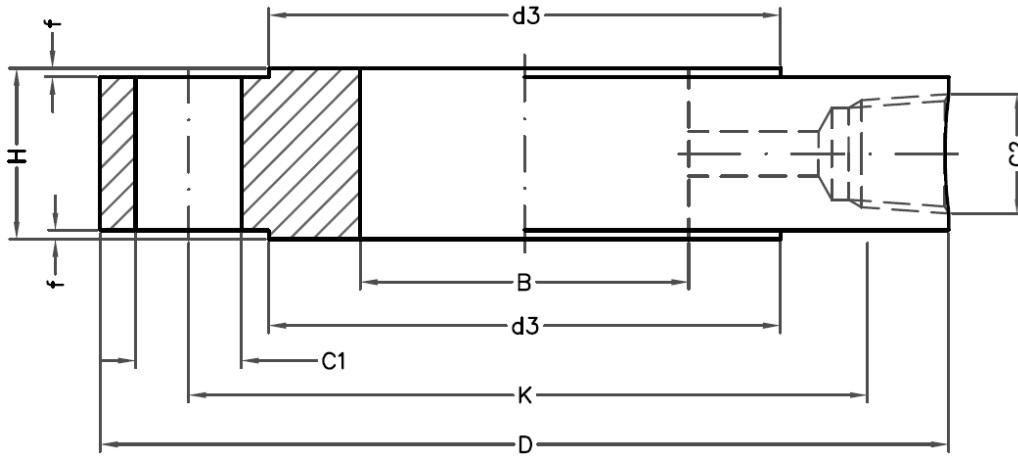

ASME B16.5 - RF FACING

size	rating	facing	H (C2=1/4")	H (C2=1/2")	B	D	f	d3	K	C1 (inch)	C1 / pcs
1"	cl. 150	RF	24	33	33	110	2	51	80	5/8"	16 / 4x
1"	cl. 300	RF	24	33	33	125	2	51	89	3/4"	19 / 4x
1"	cl. 400-600	RF	33	33	33	125	7	51	89	3/4"	19 / 4x
1"	cl. 900-1500	RF	43	43	33	150	7	51	102	1"	25 / 4x
1"	cl. 2500	RF	49	49	33	160	7	51	108	1"	25 / 4x
1,5"	cl. 150	RF	24	33	48	125	2	73	99	5/8"	16 / 4x
1,5"	cl. 300	RF	24	33	48	155	2	73	114	7/8"	22 / 4x
1,5"	cl. 400-600	RF	35	35	48	155	7	73	114	7/8"	22 / 4x
1,5"	cl. 900-1500	RF	46	46	48	180	7	73	124	1 1/8"	29 / 4x
1,5"	cl. 2500	RF	59	59	48	205	7	73	146	1 1/4"	32 / 4x
2"	cl. 150	RF	27	33	59	150	2	92	121	3/4"	19 / 4x
2"	cl. 300	RF	27	33	59	165	2	92	127	3/4"	19 / 8x
2"	cl. 400-600	RF	38	43	59	165	7	92	127	3/4"	19 / 8x
2"	cl. 900-1500	RF	52	52	59	215	7	92	165	1"	25 / 8x
2"	cl. 2500	RF	65	65	59	235	7	92	171	1 1/8"	29 / 8x
3"	cl. 150	RF	28	33	89	190	2	127	152	3/4"	19 / 4x
3"	cl. 300	RF	28	33	89	210	2	127	168	7/8"	22 / 8x
3"	cl. 400-600	RF	45	45	89	210	7	127	168	7/8"	22 / 8x
3"	cl. 900	RF	52	52	89	240	7	127	191	1"	25 / 8x
3"	cl. 1500	RF	62	62	89	265	7	127	203	1 1/4"	32 / 8x
3"	cl. 2500	RF	81	81	89	305	7	127	229	1 3/8"	35 / 8x
4"	cl. 150	RF	26	33	102	230	2	157	191	3/4"	19 / 8x
4"	cl. 300	RF	33	33	102	255	2	157	200	7/8"	22 / 8x
4"	cl. 400	RF	44	44	102	255	7	157	200	1"	25 / 8x
4"	cl. 600	RF	51	54	102	275	7	157	216	1"	25 / 8x
4"	cl. 900	RF	59	59	102	290	7	157	235	1 1/4"	32 / 8x
4"	cl. 1500	RF	68	68	102	310	7	157	241	1 3/8"	35 / 8x
4"	cl. 2500	RF	90	90	102	355	7	157	273	1 3/8"	42 / 8x

All dimensions in mm

EN 1092-1 - TYPE B1

size	rating	type	H (C2=1/4")	H (C2=1/2")	B	D	f	d3	K	C1 / pcs
DN25	PN10-40	B1	24	33	35	115	2	68	85	14 / 4x
DN25	PN63	B1	28	37	35	140	2	68	100	18 / 4x
DN25	PN100	B1	28	37	35	140	2	68	100	18 / 4x
DN40	PN10-40	B1	24	33	50	150	3	88	110	18 / 4x
DN40	PN63	B1	29	38	50	170	3	88	125	22 / 4x
DN40	PN100	B1	29	39	50	170	3	88	125	22 / 4x
DN50	PN10-40	B1	28	33	62	165	3	102	125	18 / 4x
DN50	PN63	B1	29	38	62	180	3	102	135	22 / 4x
DN50	PN100	B1	31	40	62	195	3	102	145	26 / 4x
DN80	PN10-40	B1	28	33	91	200	3	138	160	18 / 8x
DN80	PN63	B1	31	40	91	215	3	138	170	22 / 8x
DN80	PN100	B1	35	44	91	230	3	138	180	26 / 8x
DN100	PN10-16	B1	26	33	116	220	3	158	180	18 / 8x
DN100	PN25-40	B1	27	36	116	235	3	162	190	22 / 8x
DN100	PN63	B1	33	42	116	250	3	162	200	26 / 8x

All dimensions in mm

DRAWING AND DIMENSIONS STANDARD EXECUTIONS – FLUSH FLANGE WITH BDTV910 VALVE

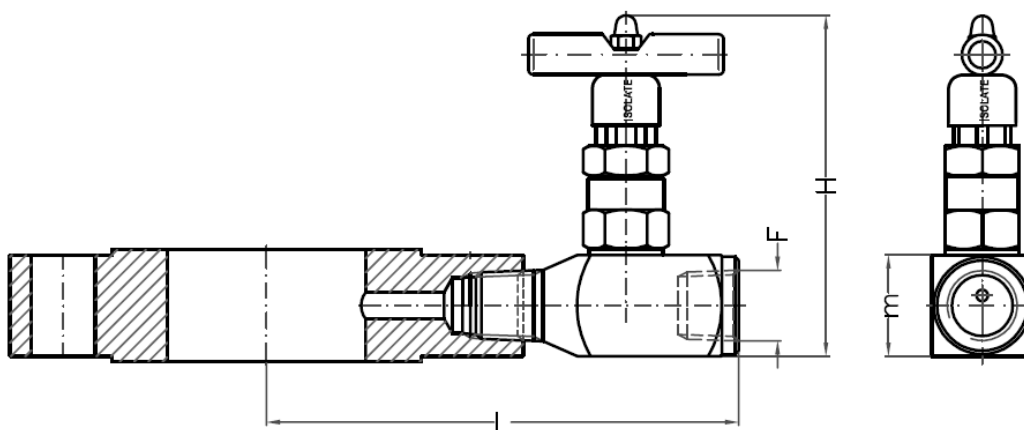

ASME B16.5 - RF FACING

Size ASME	facing	F	L	H (open)	m
1"	RF	1/4" / 1/2"	1/2 x D + 60	102	30
1.5"	RF	1/4" / 1/2"	1/2 x D + 60	102	30
2"	RF	1/4" / 1/2"	1/2 x D + 60	102	30
3"	RF	1/4" / 1/2"	1/2 x D + 60	102	30
4"	RF	1/4" / 1/2"	1/2 x D + 60	102	30

Note: for size D check flush flange ASME table
All dimensions in mm

EN 1092-1 - TYPE B1

Size EN	type	F	L	H (open)	m
DN25	B1	1/4" / 1/2"	1/2 x D + 60	102	30
DN40	B1	1/4" / 1/2"	1/2 x D + 60	102	30
DN50	B1	1/4" / 1/2"	1/2 x D + 60	102	30
DN80	B1	1/4" / 1/2"	1/2 x D + 60	102	30
DN100	B1	1/4" / 1/2"	1/2 x D + 60	102	30

Note: for size D check flush flange EN table
All dimensions in mm

Flushing ring is used for flushing solution combined with diaphragm seals. This type of flushing ring is clamped between process nozzle and diaphragm seal. The flushing ring can be combined with the BF and BRf seal as well as the BC and BRC type.



STANDARD EXECUTION

BODY	GASKET SURFACE FINISH	FACING	TYPE
AISI 316(L)	Ra 3.2-6.3 μm	RF	type B1

FLUSH CONNECTION

1/4" NPT

FLANGED PROCESS CONNECTIONS

ASME B16.5

size	rating
1"	cl. 150 - cl. 2500
1.5"	cl. 150 - cl. 2500
2"	cl. 150 - cl. 2500
3"	cl. 150 - cl. 2500
4"	cl. 150 - cl. 2500

Note: RJF facing gasket surface finish: <1.6 μm

EN 1092-1

size	rating
DN25	PN10 - PN100
DN40	PN10 - PN100
DN50	PN10 - PN100
DN80	PN10 - PN100
DN100	PN10 - PN100

API ISO 10423

size	rating	facing
1-13/16"	69 - 138 MPa	6BX - RJF
2-1/16"	13.8 - 34.5 MPa	6B - RJF
2-1/16"	69 - 138 MPa	6BX - RJF
2-9/16"	13.8 - 34.5 MPa	6B - RJF
2-9/16"	69 - 138 MPa	6Bx - RJF
3-1/8"	13.8 - 34.5 MPa	6B - RJF
3-1/8"	39 - 138 MPa	6Bx - RJF

Note: API 6A facing gasket surface finish: <1.6 μm

JIS B2220

Size	rating	facing
25 (1")	5K - 20K	RF
32 (1.25")	5K - 20K	RF
40 (1.5)	5K - 20K	RF
50 (2")	5K - 20K	RF
65 (2.5")	5K - 20K	RF
80 (3")	5K - 20K	RF
90 (3.5")	5K - 20K	RF
100 (4")	5K - 20K	RF

Note: JIS RF facing roughness is Ra 3.2-6.3 μm

FLUSHING CONNECTIONS

size	thread	norms
1/4"	NPT	ANSI B1.20.1
1/4"	BSP	ISO 228
1/2"	NPT	ANSI B1.20.1
1/2"	BSP	ISO 228

BODY MATERIALS, AND FACING OPTIONS

body material
AISI 316(L)
Monel 400
Hastelloy C-276
Duplex
Super Duplex
Inconel 600

facing (ASME B16.5)	
RF	Ra 3.2-6.3 μm
RJF	Ra <1.6 μm
LMF	Ra 3.2-6.3 μm
SMF	Ra <3.2 μm
LTF	Ra <3.2 μm
STF	Ra <3.2 μm
LGF	Ra <3.2 μm
SGF	Ra <3.2 μm
LFF	Ra 3.2-6.3 μm
SFF	Ra <3.2 μm

facing type (EN 1092-1)	
B1	Ra 3.2-12.5 μm
B2	Ra 0.8-3.2 μm
C	Ra 0.8-3.2 μm
D	Ra 0.8-3.2 μm
E	Ra 3.2-12.5 μm
F	Ra 3.2-12.5 μm
G	Ra 0.8-3.2 μm
H	Ra 0.8-3.2 μm

OPTIONS

- vent & blind plugs
- BDTV 911 valves

DRAWING AND DIMENSIONS STANDARD EXECUTIONS – RF FACING

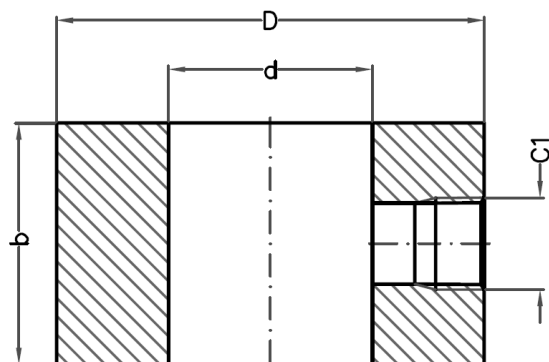

ASME B16.5 - RF FACING

size	rating	facing	b (C1=1/4")	b (C1=1/2")	D	d
1"	cl. 150-2500	RF	20	35	51	33
1.5"	cl. 150-2500	RF	20	35	73	43
2"	cl. 150-2500	RF	20	35	92	59
3"	cl. 150-2500	RF	20	35	127	89
4"	cl. 150-2500	RF	20	35	157	102

All dimensions in mm

EN 1092-1 - TYPE B1

size	rating	type	b (C1=1/4")	b (C1=1/2")	D	d
DN25	PN10-400	B1	20	35	68	33
DN40	PN10-400	B1	20	35	88	48
DN50	PN10-400	B1	20	35	102	59
DN80	PN10-400	B1	20	35	138	89
DN100	PN10-400	B1	20	35	158	102

All dimensions in mm

DRAWING AND DIMENSIONS STANDARD EXECUTIONS – RJF FACING AND API

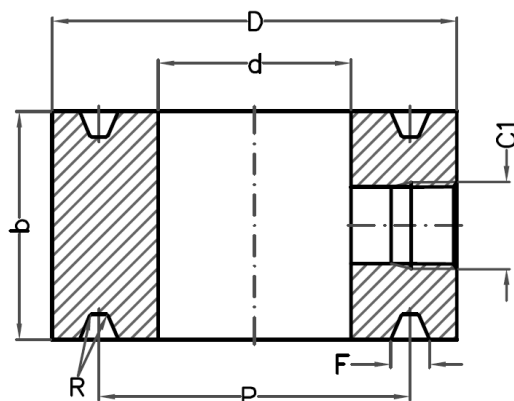

ASME B16.5 - RJF FACING

size	rating	facing	b (C1=1/4")	b (C1=1/2")	D	d	P	F	E	Ring #	R
1"	cl. 150	RJF	38	45	64	33	48	9	6	15	0.8
1"	cl. 300	RJF	38	45	70	33	51	9	6	16	0.8
1"	cl. 400-600	RJF	38	45	70	33	51	9	6	16	0.8
1"	cl. 900-1500	RJF	38	45	72	33	51	9	6	16	0.8
1"	cl. 2500	RJF	38	45	83	33	60	9	6	18	0.8
1,5"	cl. 150	RJF	38	45	83	43	65	9	6	19	0.8
1,5"	cl. 300	RJF	38	45	91	43	68	9	6	20	0.8
1,5"	cl. 400-600	RJF	38	45	91	43	68	9	6	20	0.8
1,5"	cl. 900-1500	RJF	38	45	92	43	69	9	6	20	0.8
1,5"	cl. 2500	RJF	38	50	114	43	83	12	8	23	0.8
2"	cl. 150	RJF	38	45	102	59	83	9	6	22	0.8
2"	cl. 300	RJF	38	50	108	59	83	12	8	23	0.8
2"	cl. 400-600	RJF	38	45	108	59	83	12	8	23	0.8
2"	cl. 900-1500	RJF	38	50	124	59	95	12	8	24	0.8
2"	cl. 2500	RJF	38	50	133	59	102	12	8	26	0.8
3"	cl. 150	RJF	38	45	133	89	114	9	6	29	0.8
3"	cl. 300	RJF	38	50	146	89	124	12	8	31	0.8
3"	cl. 400-600	RJF	38	50	146	89	124	12	8	31	0.8
3"	cl. 900	RJF	38	50	156	89	124	12	8	31	0.8
3"	cl. 1500	RJF	38	50	168	89	137	12	8	35	0.8
3"	cl. 2500	RJF	38	55	168	89	127	14	10	32	0.8
4"	cl. 150	RJF	38	45	171	101	149	9	6	36	0.8
4"	cl. 300	RJF	38	50	175	101	149	12	8	37	0.8
4"	cl. 400	RJF	38	50	175	101	149	12	8	37	0.8
4"	cl. 600	RJF	38	50	175	101	149	12	8	37	0.8
4"	cl. 900	RJF	38	50	181	101	149	12	8	37	0.8
4"	cl. 1500	RJF	38	50	194	101	162	12	8	39	0.8
4"	cl. 2500	RJF	38	55	203	101	157	17	11	38	0.8

All dimensions in mm

IV – DATA SHEET

ACCESSORIES – FLUSH RING

API 6A ISO 10423 - TYPE 6BX

size	rating	b (C1=1/4")	b (C1=1/2")	D	d4	K	F	E	ring	R	
1-13/16"	6BX	10M / 69MPa	38	45	105	105	146	10	6	BX-151	0.8
1-13/16"	6BX	15M / 103,5MPa	38	45	106	106	160	10	6	BX-151	0.8
1-13/16"	6BX	20M / 138MPa	38	45	117	117	203	10	6	BX-151	0.8
2-1/16"	6BX	10M / 69MPa	38	45	111	111	159	10	6	BX-152	0.8
2-1/16"	6BX	15M / 103,5MPa	38	45	114	114	175	10	6	BX-152	0.8
2-1/16"	6BX	20M / 138MPa	38	45	132	132	230	10	6	BX-152	0.8
2-9/16"	6BX	10M / 69MPa	38	50	132	132	184	11	7	BX-153	0.8
2-9/16"	6BX	15M / 103,5MPa	38	50	133	133	200	11	7	BX-153	0.8
2-9/16"	6BX	20M / 138MPa	38	50	151	151	262	11	7	BX-153	0.8
3-1/16"	6BX	10M / 69MPa	38	50	152	152	216	12	8	BX-154	0.8
3-1/16"	6BX	15M / 103,5MPa	38	50	154	154	230	12	8	BX-154	0.8
3-1/16"	6BX	20M / 138MPa	38	50	171	171	287	12	8	BX-154	0.8

All dimensions in mm

API 6A ISO 10423 - TYPE 6B

size	rating	b (C1=1/4")	b (C1=1/2")	D	d4	K	F	E	ring	R	
2-9/16"	6B	2M / 13,8MPa	38	50	108	108	127	11	8	R or RX-23	0.8
2-9/16"	6B	3M / 20,7MPa	38	50	124	124	165	11	8	R or RX-24	0.8
2-9/16"	6B	5M / 34,5MPa	38	50	124	124	165	11	8	R or RX-24	0.8
3-1/16"	6B	2M / 13,8MPa	38	50	127	127	149	11	8	R or RX-26	0.8
3-1/16"	6B	3M / 20,7MPa	38	50	137	137	191	11	8	R or RX-27	0.8
3-1/16"	6B	5M / 34,5MPa	38	50	137	137	191	11	8	R or RX-27	0.8
3-1/8"	6B	2M / 13,8MPa	38	50	146	146	168	11	8	R or RX-31	0.8
3-1/8"	6B	3M / 20,7MPa	38	50	156	156	191	11	8	R or RX-31	0.8
3-1/8"	6B	5M / 34,5MPa	38	50	168	168	203	11	8	R or RX-35	0.8

All dimensions in mm

DRAWING AND DIMENSIONS STANDARD EXECUTIONS – FLUSH RING WITH BDTV911 EXTENDED VALVE

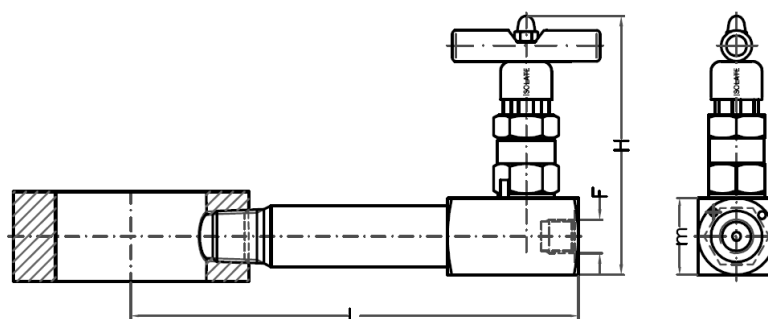

ASME B16.5 - RF FACING

Size ASME	facing	F	L	H (open)	m
1"	RF	3/8" / 1/2"	151	102	30
1.5"	RF	3/8" / 1/2"	162	102	30
2"	RF	3/8" / 1/2"	171	102	30
3"	RF	3/8" / 1/2"	189	102	30
4"	RF	3/8" / 1/2"	204	102	30

All dimensions in mm

EN 1092-1 - TYPE B1

Size EN	type	F	L	H (open)	m
DN25	B1	3/8" / 1/2"	159	102	30
DN40	B1	3/8" / 1/2"	169	102	30
DN50	B1	3/8" / 1/2"	176	102	30
DN80	B1	3/8" / 1/2"	194	102	30
DN100	B1	3/8" / 1/2"	204	102	30

All dimensions in mm

Reducer flange is used to mount a larger diaphragm seal to a smaller process connection. This type of reducer flange is clamped between process nozzle and diaphragm seal. Eccentric reducer flanges can be supplied to prevent process media remaining in the reducer ring when mounted in vertical position. The reducer flange can be combined with the BF and BRF seal as well as the BC and BRC type.



STANDARD EXECUTION

BODY	GASKET SURFACE FINISH	FACING	TYPE
AISI 316(L)	Ra 3.2-6.3 μm	RF	type B1

FLUSH CONNECTION

1/4"NPT

FLANGED PROCESS CONNECTIONS

ASME B16.5

process	seal	rating	facing
1"	3"	cl. 150	RF
1"	3"	cl. 300	RF
1"	3"	cl. 400 - cl. 600	RF
1"	3"	cl. 900 - cl. 1500	RF
1"	3"	cl. 2500	RF
2"	3"	cl. 150	RF
2"	3"	cl. 300	RF
2"	3"	cl. 400 - cl. 600	RF
2"	3"	cl. 900 - cl. 1500	RF
2"	3"	cl. 2500	RF

EN 1092-1

process	seal	rating	type
DN25	DN80	PN10-40	B1
DN25	DN80	PN63	B1
DN25	DN80	PN100	B1
DN50	DN80	PN10-40	B1
DN50	DN80	PN63	B1
DN50	DN80	PN100	B1

FLUSHING CONNECTIONS

size	thread	norms
1/4"	NPT	ANSI B1.20.1
1/4"	BSP	ISO 228
1/2"	NPT	ANSI B1.20.1
1/2"	BSP	ISO 228

BODY MATERIALS, AND FACING OPTIONS

body material
AISI 316(L)
AISI 304(L)
AISI 321
Hastelloy C-276
Monel 400
Duplex
Super Duplex
Inconel 600

facing (ASME B16.5)	
RF	Ra 3.2-6.3 μm
RJF	Ra <1.6 μm
LMF	Ra 3.2-6.3 μm
SMF	Ra <3.2 μm
FF	Ra 3.2-6.3 μm
LTF	Ra <3.2 μm
STF	Ra <3.2 μm
LGF	Ra <3.2 μm
SGF	Ra <3.2 μm
LFF	Ra 3.2-6.3 μm
SFF	Ra <3.2 μm

facing type (EN 1092-1)	
B1	Ra 3.2-12.5 μm
A	Ra 3.2-12.5 μm
B2	Ra 0.8-3.2 μm
C	Ra 0.8-3.2 μm
D	Ra 0.8-3.2 μm
E	Ra 3.2-12.5 μm
F	Ra 3.2-12.5 μm
G	Ra 0.8-3.2 μm
H	Ra 0.8-3.2 μm

OPTIONS

- eccentric execution
- vent & blind plugs
- valves BDTV910
- set of handles welded on side of flange

DRAWING AND DIMENSIONS STANDARD EXECUTIONS

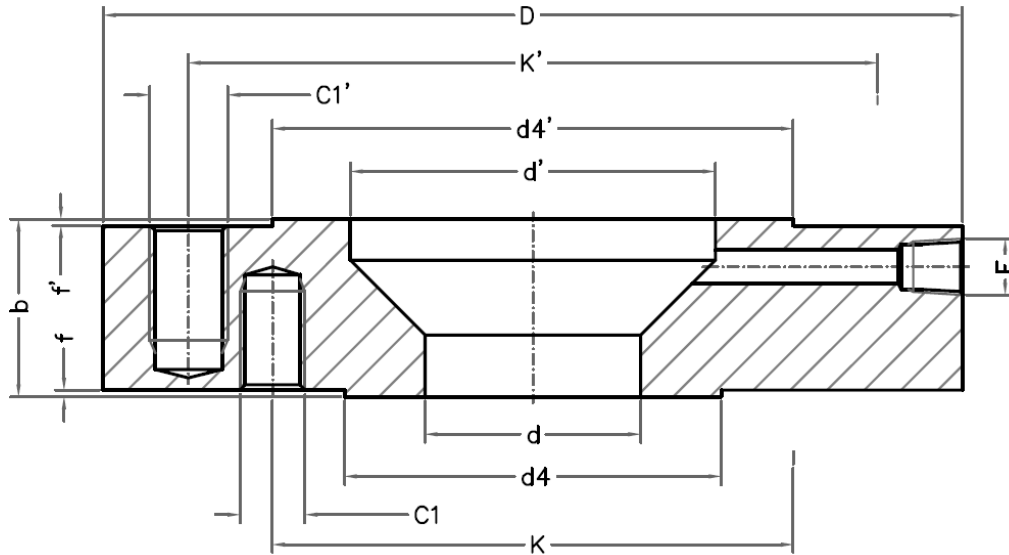

ASME B16.5 - RF FACING

process	seal	rating	facing	b	f	f'	D	K	K'	d4	d4'	d	d'	C1	C1'
1"	3"	cl. 150	RF	40	2	2	190	80	152	51	127	27	93	1/2" UNC	5/8" UNC
1"	3"	cl. 300	RF	47	2	2	210	89	168	51	127	27	93	5/8" UNC	3/4" UNC
1"	3"	cl. 400 - cl. 600	RF	47	7	7	210	89	168	51	127	27	93	5/8" UNC	3/4" UNC
1"	3"	cl. 900	RF	74	7	7	240	102	191	51	127	27	93	7/8" UNC	7/8" UNC
1"	3"	cl. 1500	RF	74	7	7	265	102	203	51	127	27	93	7/8" UNC	1 1/8" UNC
1"	3"	cl. 2500	RF	90	7	7	305	108	229	51	127	27	93	7/8" UNC	1 1/4" UNC
2"	3"	cl. 150	RF	40	2	2	190	121	152	92	127	52	93	5/8" UNC	5/8" UNC
2"	3"	cl. 300	RF	47	2	2	210	127	168	92	127	52	93	5/8" UNC	3/4" UNC
2"	3"	cl. 400 - cl. 600	RF	47	7	7	210	127	168	92	127	52	93	5/8" UNC	3/4" UNC
2"	3"	cl. 900	RF	74	7	7	240	165	191	92	127	52	93	7/8" UNC	7/8" UNC
2"	3"	cl. 1500	RF	74	7	7	265	165	203	92	127	52	93	7/8" UNC	1 1/8" UNC
2"	3"	cl. 2500	RF	90	7	7	305	171	229	92	127	52	93	1" UNC	1 1/4" UNC

All dimensions in mm

SUPPORT HANDLES

The Support Handles are available for 2” and 3” Diaphragm Seals and flush flanges to assist in easy handling during installation.

STANDARD EXECUTION

size	diameter	body	B	H	Recommended use	Included
2”	12 mm	AISI 316(L)	124	95	cl. 900 and above	cl. 2500
3”	12 mm	AISI 316(L)	160	95	cl. 400 and above	cl. 2500

DRAWING

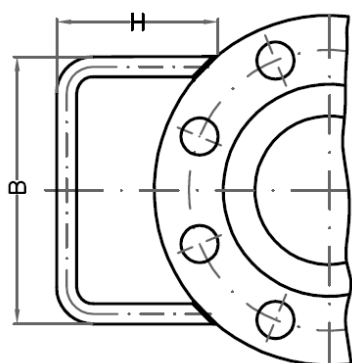

HEAVY DUTY SUPPORT TUBE

The Heavy Duty Support Tube is robust and strong version of the standard capillary connection to the Diaphragm Seal and reduces the chance of mechanical damage on capillary connection. It also prevents chloride stress corrosion on the capillary weld (IP68 execution) and reduces the temperature on capillary in order to prevent burning of personnel.

STANDARD EXECUTION

IP CLASS	BODY	LENGTH	DIAMETER	MOUNTING	SOLUTION
IP54 / IP68	AISI 316(L)	80 mm < 200°C 150 mm > 200°C	1/2” - 40S	Capillary	page 123

DRAWING

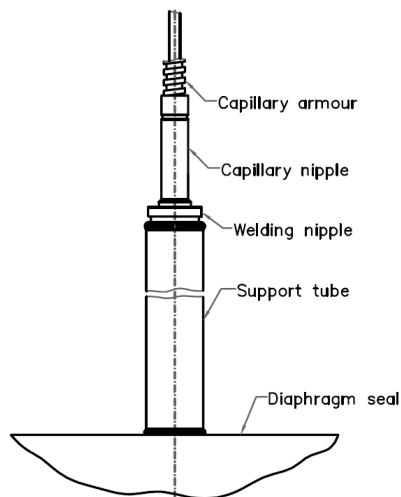

TR – TEMPERATURE REDUCER

The Temperature Reducer is used to protect the instrument from high process temperatures and is used in combination with direct mounted Diaphragm Seals.

STANDARD EXECUTION

BODY	LENGTH	MOUNTING	TEMPERATURE REDUCTION
AISI 316(L)	158mm	Direct	approx. 250°C

DRAWING

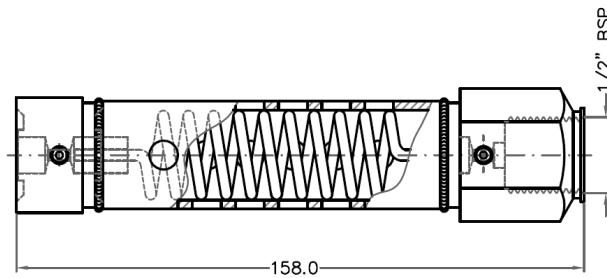

TC – TEMPERATURE COMPENSATOR

The Temperature Compensator is used to lower the response time in combination with long capillaries and high or low temperatures. It uses a specially designed secondary diaphragm and two different fill fluids to meet high temperature specifications, and keep acceptable response times.

STANDARD EXECUTION

BODY	MOUNTING	TEMPERATURE REDUCTION	FILL FLUIDS	SOLUTION
AISI 316(L)	direct/capillary	approx. 250°C	BSO-21 / BSO-36	page 114

DRAWING

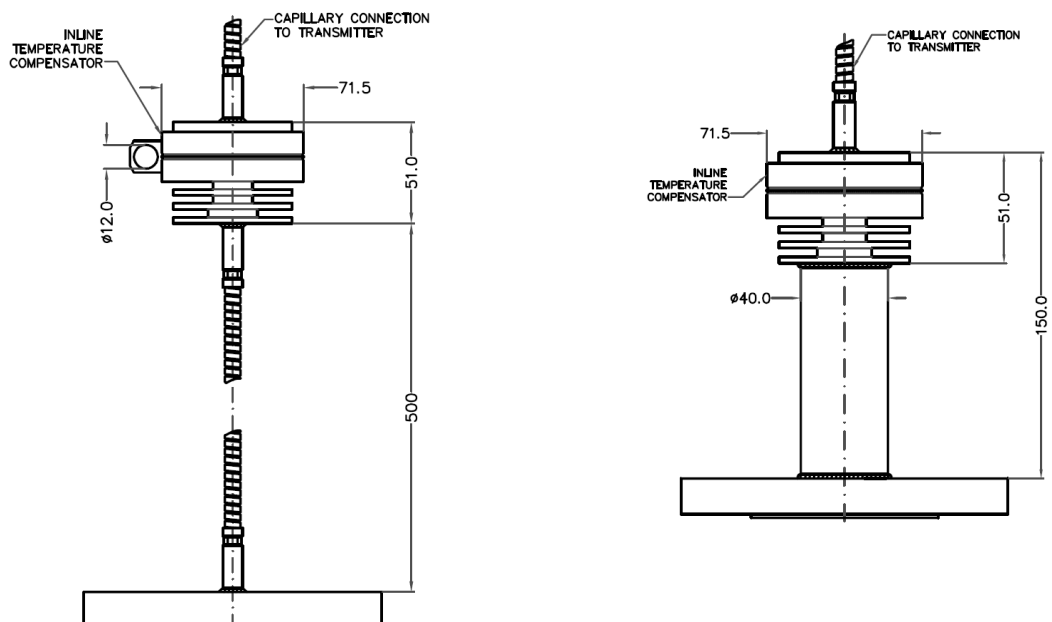

CAPILLARY

The Capillary is used to remotely mount the pressure instrument to the Diaphragm Seal. The inside diameter of the capillary has a close relation with the temperature influence and the response time of the Diaphragm Seal System.

STANDARD EXECUTION

inside diameter	outside diameter	tube	armour	MWP
1 mm	3 mm	AISI 316(L)	AISI 304	1100 bar
2 mm	4 mm	AISI 316(L)	AISI 304	850 bar

OPTIONS

- PVC protective sleeve – black
- PVC protective sleeve – white
- ATEX – protective sleeve

INTRODUCTION

It is a recognised phenomenon in the process industry that higher process pressure and temperature can improve the overall efficiency. Currently, when measuring with a transmitter with Diaphragm Seals the temperature limit of Diaphragm Seal applications is set at 420°C as this is the maximum allowed temperature of the filling fluid.



HIGH TEMPERATURE DIAPHRAGM SEAL

Badotherm has developed Diaphragm Seal that can withstand process temperatures up to 600°C. To enable a proper functioning of the Diaphragm Seal at these extreme process temperatures a revolutionary new design and principle is used. The novelty of the design is as such that Badotherm has a Patent on the High Temperature Diaphragm Seal (HTDS).

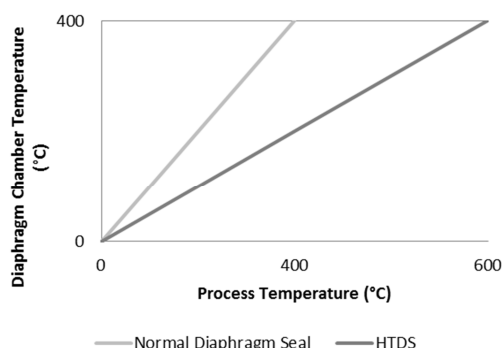

The HTDS is extensively tested in different circumstances and with various process temperatures. The graph

presents the temperature reduction measured in the diaphragm chamber compared to a normal Diaphragm Seal. The HTDS is suitable for both gauge and differential pressure transmitters.

TEMPERATURE AND STATIC PRESSURE LIMITS

The maximum temperature limit is determined by a combination of the fill fluid, and the material of the body and of bolts. With AISI-321H body material and 1.4980 bolt material the maximum temperature is 600°C (material specifications and maximum temperature according the ASME B16.5 standard). The maximum operating pressure depends on the flange rating combined with process temperature. The table below presents the temperature and pressure limits for 3 selected filling fluids.

	BSO-46	BSO-42	BSO-02
Temperature Limits			
Max. Process temp.	600°C	550°C	600°C
Min. Ambient temp.	0°C	-10°C	-40°C
Max. Ambient temp.	50°C	50°C	50°C
dP Static Pressure			
Min. (mbarg) ¹	250	1000	5000
Max. (bar)	50	50	50

¹ At maximum process temperature

ACCURACY AND OTHER SPECIFICATIONS

The table below presents the accuracy specifications of GP and DP HTDS, as well as the temperature effects, and pressure details.

	GP	DP
Min. Span required	1000 mbar	250 mbar
Transmitter min. Overpressure required	40 bar	40 bar
Accuracy²		
Span 250 mbar	-	2.0%
Span 500 mbar	-	1.0%
Span >1000 mbar		
0-25%	2.0%	1.5%
25-100%	0.5%	0.5%
Temperature effect		
Process temp.	0.39	0.20
	mbar/10°C	mbar/10°C
Ambient temp. /mtr cap.	0.59	0.25
	mbar/10°C	mbar/10°C
Capillary length	1 – 15 mtr	1 – 15 mtr

² Calibrated at nominal value at 20°C ambient temperature

INTRODUCTION

In today’s process industry there are many processes that operate with very low pressures, < 100 mbar. An example of such a process is Nitrogen blanketing which is a commonly used technique to prevent process gases entering the atmosphere. To obtain this, a small nitrogen overpressure of approximately 10 mbar is applied on a vessel with these gases. Accurate measurement of this small overpressure is necessary to minimise or even avoid interference with the process in the vessel. Besides that a significant cost reduction is achieved by limiting the consumption of nitrogen to an absolute minimum.



LOW PRESSURE MEASUREMENT WITH DIAPHRAGM SEALS

Difficulties arise when this technique is applied in a corrosive environment. In these circumstances it is often mandatory to use pressure measurement devices equipped with Diaphragm Seals. However, the use of a standard Diaphragm Seal in combination with the very low overpressure ranges implies relative high temperature effects. These high temperature effects, and especially ambient temperature effects, result in unstable, unreliable and inaccurate pressure measurement. And this subsequently results in poor control of the process.

SOLUTION DEVELOPED

After thorough analysis of the process data and requirements, Badotherm developed a Diaphragm Seal for low pressure GP applications. This solution is referred to as LGP and can be used in combination with several seal types. Test results obtained by measuring low gauge pressures showed that the minimum GP range reduces from 80 mbar with a standard Diaphragm Seal to only 5

mbar with the LGP Diaphragm Seal. Similarly the ambient temperature effect reduces from 0.4 mbar per 10°C to 0.03 mbar, while the process temperature effect reduces from 0.39 to 0.09 mbar.

Besides the accurate measuring of low pressure and limiting the consumption of nitrogen two other issues were solved. Firstly, the way of mounting the transmitter to the vessels has no effect on the zero and span adjustments of the transmitter. Secondly, there is no effect on the performance by a change in density of the fill fluid caused by ambient temperature fluctuations.

TECHNICAL SPECIFICATIONS

The Diaphragm Seal type LGP is standard manufactured in AISI316(L). It can also be supplied with all kinds of exotic materials as wetted parts. The LGP solution needs to be mounted on a DP transmitter.

	STD 3"	LGP 3"
Min. GP range (mbar)	80	5
Min. Capillary length (mtr)	direct	0.5
Ambient temp. effect (mbar)		
Capillary (per mtr)	0.4 /10°C	0.03 /10°C
Transmitter	0.19 /10°C	0.02 /10°C
Process temp. effect (mbar)		
Diaphragm Seal	0.39 /10°C	0.09 /10°C

CALCULATION EXAMPLE

Below a calculation example with the above mentioned specifications is presented.

	BF 3"	BF-LGP 3"
Process Pressure (mbar)	80	80
Capillary length (mtr)	5	5
Fill fluid	BSO-22	BSO-22
Temp. at calibration	20°C	20°C
Ambient temp.	40°C	40°C
Process temp.	140°C	140°C
Temp. effect (mbar)		
Diaphragm Seal	4.68	1.08
Capillary	4	0.3
Transmitter	0.38	0.04
Total temp. effect (mbar)	9.06	1.42
Total Probable Error (TPE)	11.3%	1.8%

INTRODUCTION HYDROGEN PERMEATION

Hydrogen is the lightest and most abundant chemical element. Hydrogen is not considered to be corrosive, still problems with Diaphragm Seals can occur under specific circumstances. These can be with high process temperature in combination with high process pressure, a galvanic reaction, or with high temperature steam.

Hydrogen is normally found in a diatomic state, H² molecules, composed of two hydrogen atoms. In a diatomic state, molecules will not permeate the diaphragm. However, if the hydrogen splits into two H⁺ atoms, it can permeate the diaphragm as H⁺ ions are smaller than the space between molecules of the diaphragm material.

After permeation through the diaphragm, H⁺ ions can unite into H² molecules which become trapped inside the Diaphragm Seal. H² will dissolve into the Diaphragm Seal fill fluid and over time the seal fill fluid will become saturated, a hydrogen bubble will appear, and the measurement will fail.

When the process pressure drops, the trapped H² ions are not able to permeate back and remain in the Diaphragm Seal system. With the H² molecules in the system the pressure within the Diaphragm Seal could remain as high as the original process pressure. The result is that the diaphragm will bulge, which leads to a zero and span shift and reduces the performance of the Diaphragm Seal system.

SOLUTION DEVELOPED

To protect the diaphragm seal diaphragm against the H⁺ ions permeation a Gold Coating is advised. Badotherm offers a 40µm and 25µm thickness for Gold Coating on Diaphragm Seals.

Normally, the temperature limit of Gold Coating is 280°C, because of by the intermediate layer of nickel. Above this limit a normal Gold Coating will be damaged or even detached from the diaphragm. Together with TNO Delft, which is an independent Dutch Research Organisation, Badotherm developed a new procedure to plate the gold directly to the diaphragm without any intermediate layer. With this new type of procedure the temperature limit on Gold Coating is increased to 400°C.

The 40µm Gold Coating thickness was engineered and designed specifically for the Hycon project in The Netherlands. Because in this project the operating temperatures (320°C) and pressures (180 bar) were extreme, additional tests on various thicknesses were executed by TNO. The result was that only a 40µm thickness could warrant the non porosity for H⁺ ions.

CHEMICAL RESISTANCE

As the Gold Coating protects the diaphragm to even the smallest molecules it is also very suitable to increase the Chemical Resistance of the Diaphragm Seal. For protection against Hydrogen Permeation the diaphragm only is coated, but to ensure Chemical Resistance the Gold Coating is extended to the outside diameter of the gasket surface.

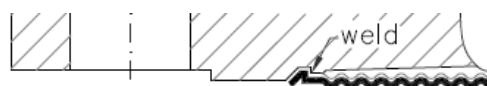

Hydrogen Permeation

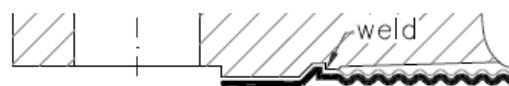

Hydrogen Permeation and Chemical Resistance

TECHNICAL SPECIFICATIONS

The table below presents the technical specifications of the Gold Coating for Diaphragm Seals.

	25µm HP	25µm HP+CR	40µm HP	40µm HP+CR
Maximum temp.	400°C	400°C	400°C	400°C
Diaphragm Seal type				
BF	•	•	•	•
BRF	-	•	-	•
BC	•	•	•	•
BRC	-	•	-	•
US	-	•	-	•
USL	-	•	-	•
BHS	-	•	-	•
Diaphragm Material				
AISI 316(L)	•	•	•	•
Monel 400*	•	•	•	•
Hastelloy C276*	•	•	•	•

HP = Hydrogen Permeation; CR = Chemical Resistance

* Maximum temperature 200°C

INTRODUCTION

It is extremely complex to measure low pressures of at high process temperatures with Diaphragm Seals. The available fluids that can withstand these temperature and pressure conditions mostly have a very high viscosity. Additionally, when there is also a considerable capillary length (> 1 meter) required the viscosity of these fill fluids, certainly at lower ambient temperatures, becomes so high that the response time of the transmitter with Diaphragm Seal becomes unacceptable.



SOLUTION DEVELOPED

To overcome this problem Badotherm has designed a 'Temperature Compensator' solution. This description does not completely cover the functionality of the design because it not only compensates for temperature, but also for response time.

The compensator has a specially designed second diaphragm that is placed between the Diaphragm Seal and the transmitter. The first part between the Diaphragm Seal and the Temperature compensator is filled with high temperature fill fluid with a high viscosity. After the Temperature Compensator the process temperature is reduced to approximately ambient temperature and those conditions are acceptable for fill fluids with a low viscosity. The lower viscosity, even at lower ambient temperatures and longer capillary lengths, reduces the overall response time of the Diaphragm Seals System.

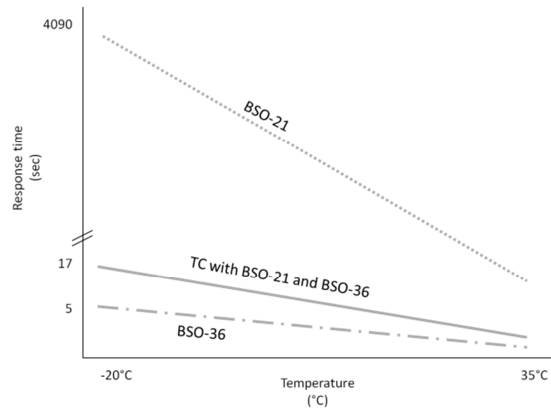

Example of Temperature Compensator with BSO-21 and BSO-36

The temperature compensator is available for all Diaphragm Seals to be combined with pressure transmitters.

INTRODUCTION

A leaking diaphragm is often detected too late, with harmful and costly consequences to the process or the environment. As a solution for this problem Badotherm has invented the Diaphragm Leakage Detection system for Diaphragm Seal Applications. The advantages of the DLD system are:

- Early alert: diaphragm leaks are discovered immediately after a leak occurs
- Cost-saving: instant action can be taken to avoid costly production contamination
- Environmental protection: harmful release of aggressive process fluids can be prevented
- Process protection: formation of bacteria is prevented

PRINCIPLES DLD SYSTEM

When a diaphragm is damaged, the process medium will seep into the seal filling fluid, changing the conductivity of the fluid. This change in conductivity is detected by a built-in sensor, with an output to an alarm or any kind of output signal.

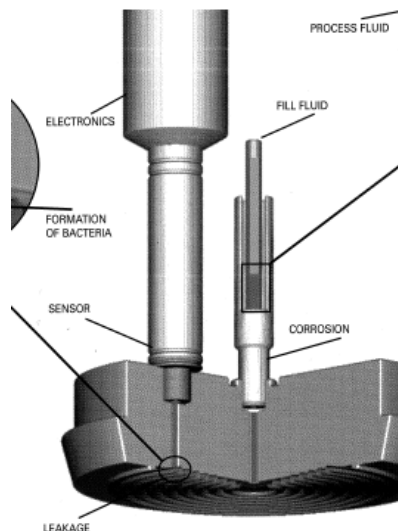

The DLD system is mainly designed for the food and beverage industry. There, a leak in the diaphragm can lead to unwanted formation of bacteria, caused by the residues in the Diaphragm Seal system. The DLD system is of course also suitable in the chemical and petrochemical industry to avoid wastage and environmental dam-

age by a leaking diaphragm. The DLD system can restrict the damage by an early detection of the leakage.

RANGE OF APPLICATION

The DLD system can be put on several Badotherm Diaphragm Seal system with a flanged or sanitary process connection larger than 1.5". The DLD is suitable for aggressive process media. Here, it is possible that less protected parts of the Diaphragm Seal system would be corroded, by the invasion of process fluid. This could lead to a dangerous and harmful release of process fluid.

TECHNICAL SPECIFICATIONS

The DLD can be executed with EX proof head without electronics and with a sensitivity sensor <math>< 1\text{m}\Omega</math>.

INTRODUCTION

Diaphragm seals with a capillary connection can be installed at vulnerable locations, with high concentration of chloride, high temperatures, or locations that can be influenced by mechanical damage or a combination of all three. One of the weakest points in a Diaphragm Seal System is the connection between the seal and the capillary and all of the influences mentioned above can easily damage the welded capillary connection. When the capillary connection is damaged the Diaphragm Seal System can even start leaking which results in a loss of measurement.

SOLUTION DEVELOPED

To overcome this problem Badotherm has designed a 'Heavy Duty Support Tube' solution. This description does not completely cover the functionality of the design, because it not only can be used for heavy duty environments, but also at locations where the weld of the capillary should be protected against environmental chloride stress corrosion.

Key features of the Heavy Duty Support tube are:

- Reduction of temperature on capillary in order to prevent burning of personnel
- Reduce the chance of mechanical damage on capillary connection
- Prevent chloride stress corrosion on the capillary weld (IP68 execution only)

The Heavy Duty Support Tube is available in two types, the IP57 tube and the IP68. The IP57 has the function of temperature reduction and reduction of mechanical damage. The IP68 edition has the extra feature that it hermetically seals the capillary weld from environmental influences such as chloride fumes and fluid. The soldered tube end prevents the fumes and the rain combined with these fumes to 'attack' welded connection.

TECHNICAL SPECIFICATIONS

The Heavy Duty Support Tube has had extensive testing in the process simulation environment in the Badotherm facility and in the "Field" with key customers. The temperature test has proven that the temperature reduction is significantly. When a process temperature of 300°C in an environment temperature of 20°C is applied, the Diaphragm Seal temperature on the end of 80mm extension tube reduces to approximately 70°C. The 150mm extension tube reduces the temperature at the capillary side to approximately 35°C. Both temperatures are safe for personnel and nearby equipment.

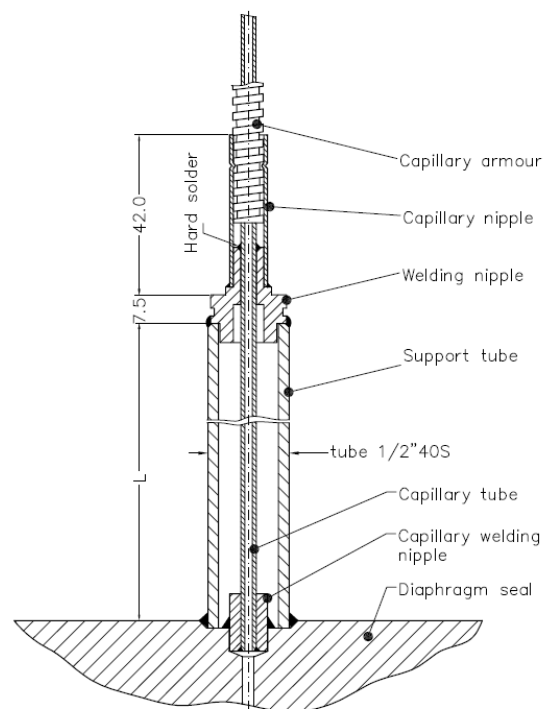

INTRODUCTION

The raised face covered Diaphragm Seal is the solution for flanged seals with exotic wetted parts. The Diaphragm Seals are designed to prevent contact of the process medium with the AISI316 seal body materials. All wetted parts of BRF/BRC type Diaphragm Seals are covered with an exotic diaphragm material.



SOLUTION DEVELOPED

The double weld technology makes it possible to keep the wetted parts (a) of the diaphragm material properties uninfluenced by the welding operation to the 316 body material (b). The inner weld (c) is located on the wetted part and is welded with the latest resistance weld technology. The resistance weld is helium tested in order to exclude leaks in the welded area. The outer weld (d) is welded with TIG welding technology and is a non-wetted part. The gasket surface (e) between the resistance weld and the TIG weld is fully covered with the exotic diaphragm material and has the appropriate roughness.

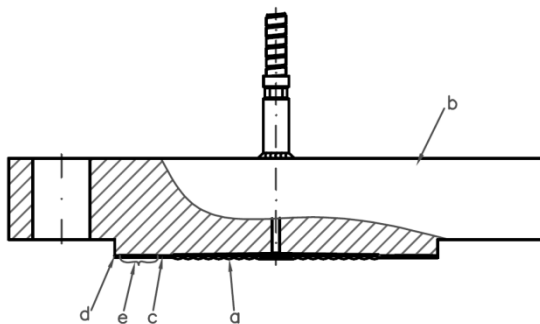

TECHNICAL SPECIFICATIONS

The table below presents the various Exotic diaphragm materials that can be used in combination with 316 body material.

	BRF	BRC
Wetted Parts		
Hastelloy C-276	●	●
Monel 400	○	○
Hastelloy B2	○	○
Tantalum	○	○
Nickel 201	○	○
Niobium	○	○
AISI 321	○	○
Inconel 600	○	○
Duplex	○	○
AISI 316 UG	○	○

● = standard / ○ = optional

Flange Rating cl. 150

Process Connection size		1/2"	3/4"	1"	1.25"	1.5"	2"	2.5"	3"	4"
Outside diameter flange	O	135	140	160	185	205	235	265	305	355
Minimum thickness excl. RF	Tf	32,2	33,8	37	40,1	46,5	52,9	59,2	68,7	78,2
Groove number		13	16	18	21	23	26	28	32	38
Pitch	P	42,88	50,8	60,33	72,23	82,55	101,6	111,13	127	157,18
Depth	E	6,35	6,35	6,35	7,92	7,92	7,92	9,52	9,52	11,13
Width	F	8,74	8,74	8,74	11,91	11,91	11,91	13,49	13,49	16,66
Diameter raised portion	K	65	73	82,5	102	114	133	149	168	203
Radius at bottom	R	0,8	0,8	0,8	0,8	0,8	0,8	0,8	0,8	0,8
Facing height: RF	f	2	2	2	2	2	2	2	2	2
Facing height: LMF, SMF, SFF, LTF, STF, LGF	f	7	7	7	7	7	7	7	7	7
Outside diameter RF, LMF, LTF	d4/R	34,9	42,9	50,8	63,5	73	92,1	104,8	127	157,2
Outside diameter SMF	d4	18,3	23,8	30,2	38,1	44,4	57,2	68,3	84,1	109,5
Outside diameter LGF	W	36,5	44,4	52,4	65,1	74,6	93,7	106,4	128,6	158,8
Outside diameter SFF	X	19,9	25,4	31,8	39,7	46	58,8	69,8	85,7	111,1
Outside diameter SGF	Y	36,5	44,4	49,2	58,7	65,1	84,1	96,8	119,1	146
Outside diameter STF	T	35,1	42,9	47,8	57,2	63,5	82,6	95,2	117,5	144,5
Inside diameter STF, LTF	U	25,4	33,3	38,1	47,6	54	73	85,7	108	131,8
Diameter bolt circle		88,9	95,2	108	130,2	146	171,4	196,8	228,6	273
# boltholes		4	4	4	4	4	8	8	8	8
Size bolt holes		7/8	7/8	1	1 1/8	1 1/4	1 1/8	1 1/4	1 3/8	1 5/8

Note: to calculate size b use Tf + f for the specific facing
All dimensions in mm

Facing RF/SMF/LMF

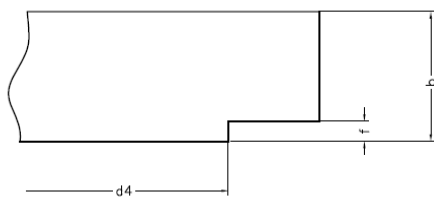

Facing RJF

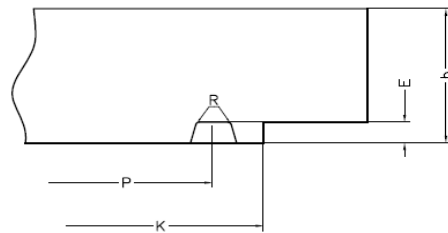

Facing LGF/SGF

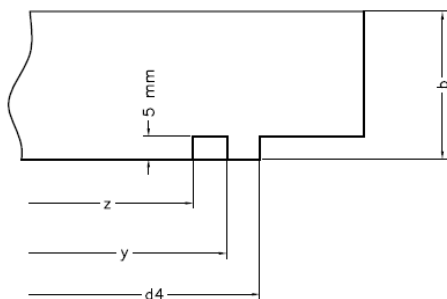

Facing STF/LTF

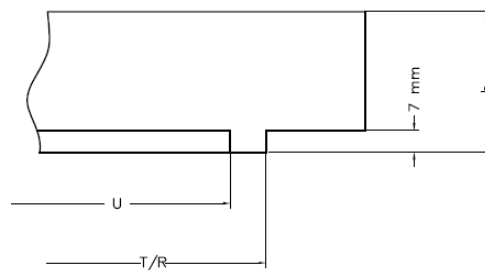

Flange Rating cl. 300

Process Connection size		1/2"	3/4"	1"	1.25"	1.5"	2"	2.5"	3"	4"
Outside diameter flange	O	95	115	125	135	155	165	190	210	255
Minimum thickness excl. RF	Tf	14,7	16,3	17,9	19,5	21,1	22,7	25,9	29	32,2
Groove number		11	13	16	18	20	23	26	31	37
Pitch	P	34,14	42,88	50,8	60,33	68,27	80,55	101,6	123,83	149,23
Depth	E	5,54	6,35	6,35	6,35	6,35	7,92	7,92	7,92	7,92
Width	F	7,14	8,74	8,74	8,74	8,74	11,91	11,91	11,91	11,91
Diameter raised portion	K	51	63,5	70	79,5	90,5	108	127	146	175
Radius at bottom	R	0,8	0,8	0,8	0,8	0,8	0,8	0,8	0,8	0,8
Facing height: RF	f	2	2	2	2	2	2	2	2	2
Facing height: LMF, SMF, SFF, LTF, STF, LGF	f	7	7	7	7	7	7	7	7	7
Outside diameter RF, LMF, LTF	d4/R	34,9	42,9	50,8	63,5	73	92,1	104,8	127	157,2
Outside diameter SMF	d4	18,3	23,8	30,2	38,1	44,4	57,2	68,3	84,1	109,5
Outside diameter LGF	W	36,5	44,4	52,4	65,1	74,6	93,7	106,4	128,6	158,8
Outside diameter SFF	X	19,9	25,4	31,8	39,7	46	58,8	69,8	85,7	111,1
Outside diameter SGF	Y	36,5	44,4	49,2	58,7	65,1	84,1	96,8	119,1	146
Outside diameter STF	T	35,1	42,9	47,8	57,2	63,5	82,6	95,2	117,5	144,5
Inside diameter STF, LTF	U	25,4	33,3	38,1	47,6	54	73	85,7	108	131,8
Diameter bolt circle		66,7	82,6	88,9	98,4	114,3	127	149,2	168,3	200
# boltholes		4	4	4	4	4	8	8	8	8
Size bolt holes		5/8	3/4	3/4	3/4	3/4	3/4	7/8	7/8	7/8

Note: to calculate size b use Tf + f for the specific facing
All dimensions in mm

Facing RF/SMF/LMF

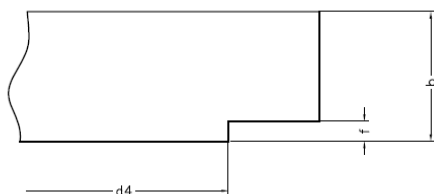

Facing RJF

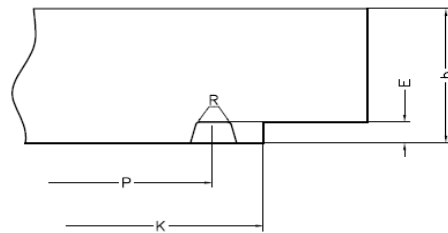

Facing LGF/SGF

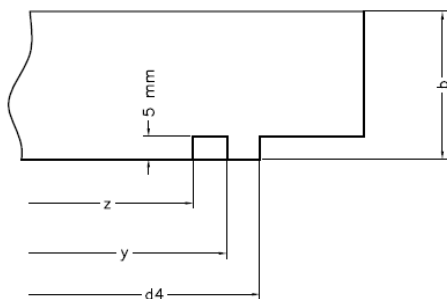

Facing STF/LTF

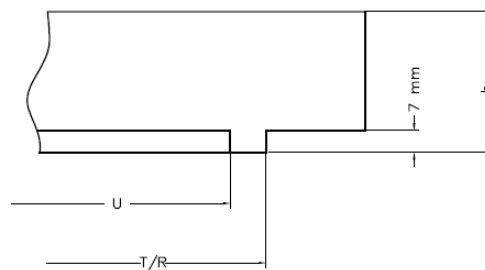

Flange Rating cl. 400-600

Process Connection size		1/2"	3/4"	1"	1.25"	1.5"	2"	2.5"	3"	4" cl.400	4" cl.600
Outside diameter flange	O	95	115	125	135	155	165	190	210	255	275
Minimum thickness excl. RF	Tf	16,3	17,9	19,5	22,7	24,3	27,4	30,6	33,8	35	37
Groove number		11	13	16	18	20	23	26	31	37	37
Pitch	P	34,14	42,88	50,8	60,33	68,27	80,55	101,6	123,83	149,23	149,23
Depth	E	5,54	6,35	6,35	6,35	6,35	7,92	7,92	7,92	7,92	7,92
Width	F	7,14	8,74	8,74	8,74	8,74	11,91	11,91	11,91	11,91	11,91
Diameter raised portion	K	51	63,5	70	79,5	90,5	108	127	146	175	175
Radius at bottom	R	0,8	0,8	0,8	0,8	0,8	0,8	0,8	0,8	0,8	0,8
Facing height: RF, LMF, SMF, LTF, STF	f	7	7	7	7	7	7	7	7	7	7
Facing height: LFF, SFF, LGF, SGF	f	5	5	5	5	5	5	5	5	5	5
Outside diameter RF, LMF, LTF	d4/R	34,9	42,9	50,8	63,5	73	92,1	104,8	127	157,2	157,2
Outside diameter SMF	d4	18,3	23,8	30,2	38,1	44,4	57,2	68,3	84,1	109,5	109,5
Outside diameter LGF	W	36,5	44,4	52,4	65,1	74,6	93,7	106,4	128,6	158,8	158,8
Outside diameter SFF	X	19,9	25,4	31,8	39,7	46	58,8	69,8	85,7	111,1	111,1
Outside diameter SGF	Y	36,5	44,4	49,2	58,7	65,1	84,1	96,8	119,1	146	146
Outside diameter STF	T	35,1	42,9	47,8	57,2	63,5	82,6	95,2	117,5	144,5	144,5
Inside diameter STF, LTF	U	25,4	33,3	38,1	47,6	54	73	85,7	108	131,8	131,8
Diameter bolt circle		66,7	82,6	88,9	98,4	114,3	127	149,2	168,3	200	215,9
# boltholes		4	4	4	4	4	8	8	8	8	8
Size bolt holes		5/8	3/4	3/4	5/8	7/8	3/4	7/8	7/8	1	1

Note: to calculate size b use Tf + f for the specific facing
All dimensions in mm

Facing RF/SMF/LMF

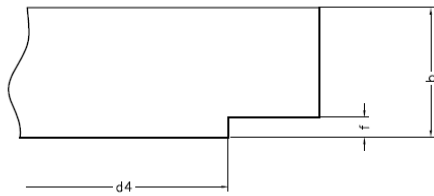

Facing RJF

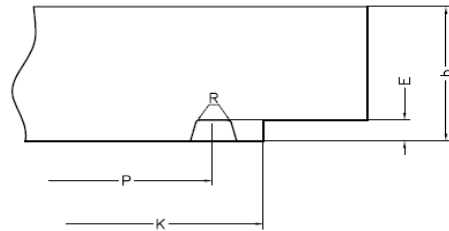

Facing LGF/SGF

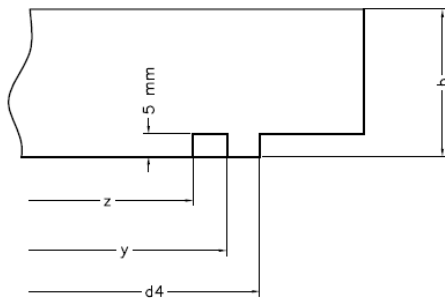

Facing STF/LTF

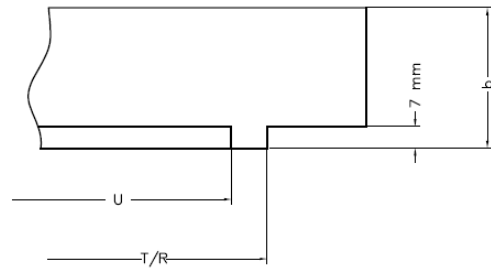

Flange Rating cl. 900-1500

Process Connection size		1/2"	3/4"	1"	1.25"	1.5"	2"	2.5"	3"	3"	4"	4"
									cl.900	cl.1500	cl.900	cl.1500
Outside diameter flange	O	120	130	150	160	180	215	245	240	265	290	310
Minimum thickness excl. RF	Tf	24,3	27,4	30,6	30,6	33,8	40,1	43,3	38,1	40,1	44,5	46,5
Groove number		12	14	16	18	20	24	27	31	35	37	39
Pitch	P	34,14	42,88	50,8	60,33	68,27	80,55	101,6	123,83	123,83	149,23	149,23
Depth	E	6,35	6,35	6,35	6,35	6,35	7,92	7,92	7,92	7,92	7,92	7,92
Width	F	7,14	8,74	8,74	8,74	8,74	11,91	11,91	11,91	11,91	11,91	11,91
Diameter raised portion	K	60,5	66,5	71,5	81	92	124	137	156	168	181	194
Radius at bottom	R	0,8	0,8	0,8	0,8	0,8	0,8	0,8	0,8	0,8	0,8	0,8
Facing height: RF, LMF, SMF, LTF, STF	f	7	7	7	7	7	7	7	7	7	7	7
Facing height: LFF, SFF, LGF, SGF	f	5	5	5	5	5	5	5	5	5	5	5
Outside diameter RF, LMF, LTF	d4/R	34,9	42,9	50,8	63,5	73	92,1	104,8	127	127	157,2	157,2
Outside diameter SMF	d4	18,3	23,8	30,2	38,1	44,4	57,2	68,3	84,1	84,1	109,5	109,5
Outside diameter LFF, LGF	W	36,5	44,4	52,4	65,1	74,6	93,7	106,4	128,6	128,6	158,8	158,8
Outside diameter SFF	X	19,9	25,4	31,8	39,7	46	58,8	69,8	85,7	85,7	111,1	111,1
Outside diameter SGF	Y	36,5	44,4	49,2	58,7	65,1	84,1	96,8	119,1	119,1	146	146
Outside diameter STF	T	35,1	42,9	47,8	57,2	63,5	82,6	95,2	117,5	117,5	144,5	144,5
Inside diameter STF, LTF	U	25,4	33,3	38,1	47,6	54	73	85,7	108	108	131,8	131,8
Diameter bolt circle		82,6	88,9	101,6	111,1	123,8	165,1	190,5	190,5	203,2	235	241,3
# boltholes		4	4	4	4	4	8	8	8	8	8	8
Size bolt holes		7/8	7/8	1	1	1 1/8	1	1 1/8	1 1/4	1 1/4	1 3/8	1 3/8

Note: to calculate size b use Tf + f for the specific facing
All dimensions in mm

Facing RF/SMF/LMF

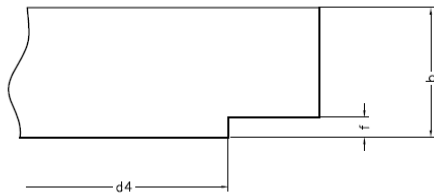

Facing RJF

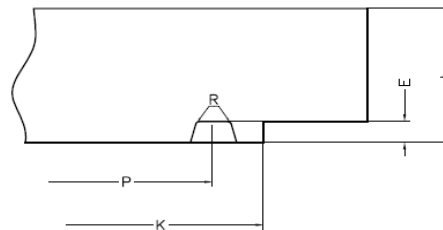

Facing LGF/SGF

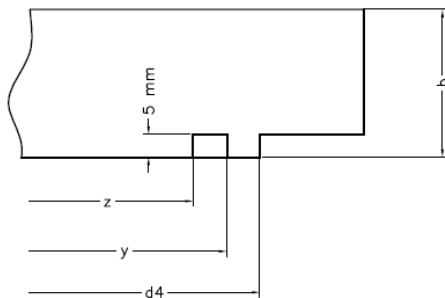

Facing STF/LTF

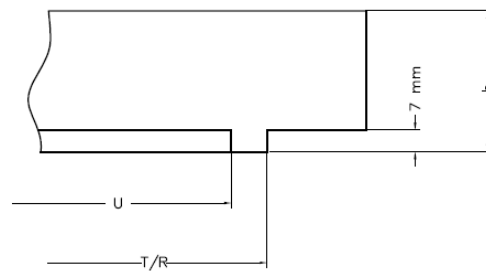

Flange Rating cl. 2500

Process Connection size		1/2"	3/4"	1"	1.25"	1.5"	2"	2.5"	3"	4"
Outside diameter flange	O	135	140	160	185	205	235	265	305	355
Minimum thickness excl. RF	Tf	32,2	33,8	37	40,1	46,5	52,9	59,2	68,7	78,2
Groove number		13	16	18	21	23	26	28	32	38
Pitch	P	42,88	50,8	60,33	72,23	82,55	101,6	111,13	127	157,18
Depth	E	6,35	6,35	6,35	7,92	7,92	7,92	9,52	9,52	11,13
Width	F	8,74	8,74	8,74	11,91	11,91	11,91	13,49	13,49	16,66
Diameter raised portion	K	65	73	82,5	102	114	133	149	168	203
Radius at bottom	R	0,8	0,8	0,8	0,8	0,8	0,8	0,8	0,8	0,8
Facing height: RF, LMF, SMF, LTF, STF	f	7	7	7	7	7	7	7	7	7
Facing height: LFF, SFF, LGF, SGF	f	5	5	5	5	5	5	5	5	5
Outside diameter RF, LMF, LTF	d4/R	34,9	42,9	50,8	63,5	73	92,1	104,8	127	157,2
Outside diameter SMF	d4	18,3	23,8	30,2	38,1	44,4	57,2	68,3	84,1	109,5
Outside diameter LFF, LGF	W	36,5	44,4	52,4	65,1	74,6	93,7	106,4	128,6	158,8
Outside diameter SFF	X	19,9	25,4	31,8	39,7	46	58,8	69,8	85,7	111,1
Outside diameter SGF	Y	36,5	44,4	49,2	58,7	65,1	84,1	96,8	119,1	146
Outside diameter STF	T	35,1	42,9	47,8	57,2	63,5	82,6	95,2	117,5	144,5
Inside diameter STF, LTF	U	25,4	33,3	38,1	47,6	54	73	85,7	108	131,8
Diameter bolt circle		88,9	95,2	108	130,2	146	171,4	196,8	228,6	273
# boltholes		4	4	4	4	4	8	8	8	8
Size bolt holes		7/8	7/8	1	1 1/8	1 1/4	1 1/8	1 1/4	1 3/8	1 5/8

Note: to calculate size b use Tf + f for the specific facing
All dimensions in mm

Facing RF/SMF/LMF

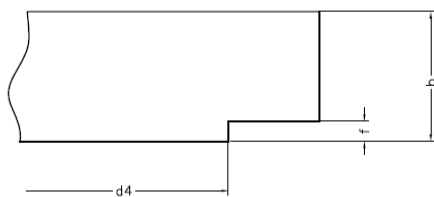

Facing RJF

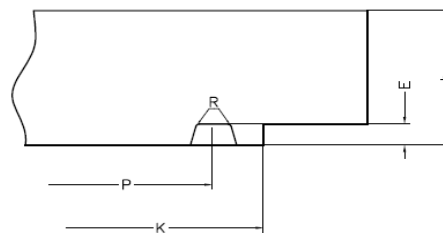

Facing LGF/SGF

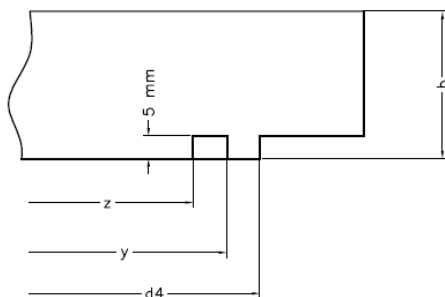

Facing STF/LTF

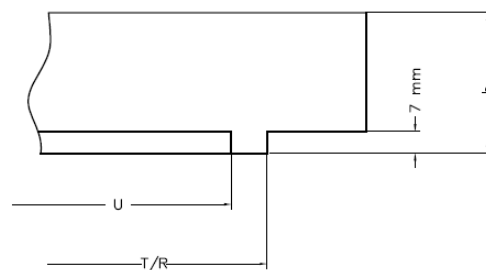

Pressure Rating PN10-16

Process Connection size		DN15	DN20	DN25	DN40	DN50	DN80	DN100
Outside diameter flange	O	95	105	115	150	165	200	220
Minimum thickness incl facing	b	14	16	16	18	20	20	22
Facing height Type B, D, F	f	2	2	2	3	3	3	3
Facing height Type C, E	f	7	7	7	7	7	7	7
Outside diameter facing Type B, D, F	d4	45	58	68	88	102	138	158
Outside diameter Tongue/Spigot Type C, E	d4	39	50	57	75	87	120	149
Outside diameter groove/recess Type D, F	Y	40	51	58	76	88	121	150
Inside diameter groove Type D	Z	28	35	42	72	72	105	128
Inside diameter Tongue Type C	W	29	36	43	61	73	106	129
diameter bolt circle		65	75	85	110	125	160	180
# boltholes		4	4	4	4	4	8	8
size bolt holes		14	14	14	18	18	18	18

All dimensions in mm

Type B, Type E

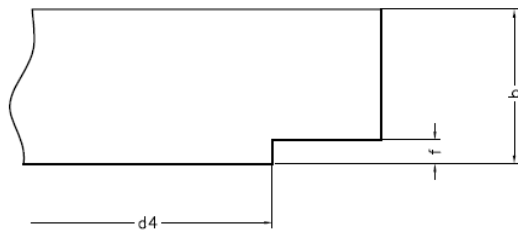

Type C

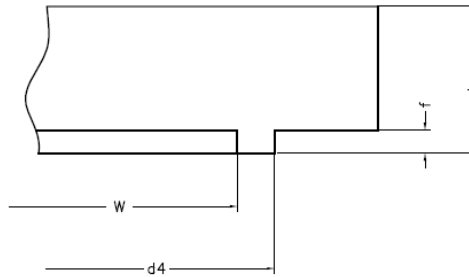

Type D

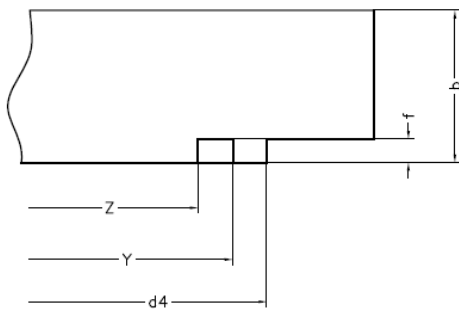

Type F

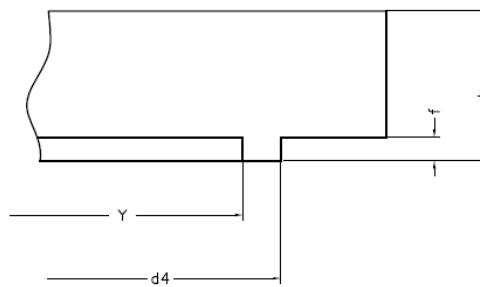

Pressure Rating PN25-40

Process Connection size		DN15	DN20	DN25	DN40	DN50	DN80	DN100
Outside diameter flange	O	95	105	115	150	165	200	220
Minimum thickness incl facing	b	14	16	16	18	20	24	26
Facing height Type B, D, F	f	2	2	2	3	3	3	3
Facing height Type C, E	f	7	7	7	7	7	7	7
Outside diameter facing Type B, D, F	d4	45	58	68	88	102	138	158
Outside diameter Tongue/Spigot Type C, E	d4	39	50	57	75	87	120	149
Outside diameter groove/recess Type D, F	Y	40	51	58	76	88	121	150
Inside diameter groove Type D	Z	28	35	42	72	72	105	128
Inside diameter Tongue Type C	W	29	36	43	61	73	106	129
diameter bolt circle		65	75	85	110	125	160	180
# boltholes		4	4	4	4	4	8	8
size bolt holes		14	14	14	18	18	18	18

All dimensions in mm

Type B, Type E

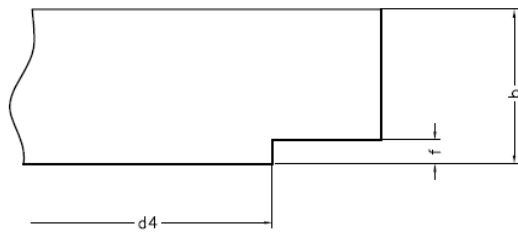

Type C

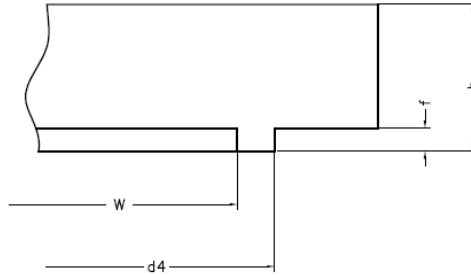

Type D

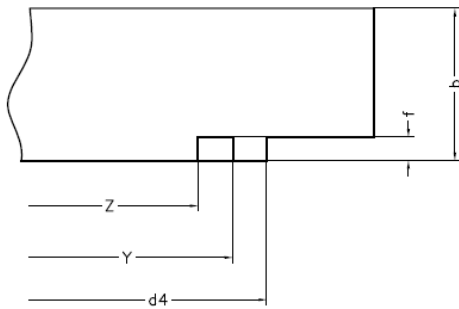

Type F

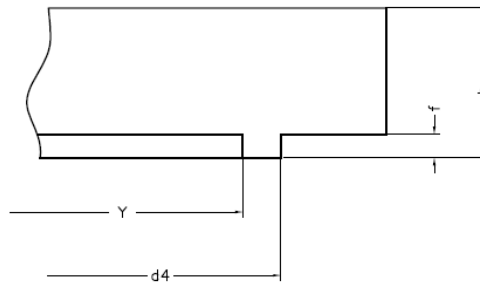

Pressure Rating PN63

Process Connection size		DN15	DN20	DN25	DN40	DN50	DN80	DN100
Outside diameter flange	O	105	130	140	170	180	215	250
Minimum thickness incl facing	b	20	22	24	26	26	30	32
Facing height Type B, D, F	f	2	2	2	3	3	3	3
Facing height Type C, E	f	7	7	7	7	7	7	7
Outside diameter facing Type B, D, F	d4	45	58	68	88	102	138	158
Outside diameter Tongue/Spigot Type C, E	d4	39	50	57	75	87	120	149
Outside diameter groove/recess Type D, F	Y	40	51	58	76	88	121	150
Inside diameter groove Type D	Z	28	35	42	72	72	105	128
Inside diameter Tongue Type C	W	29	36	43	61	73	106	129
diameter bolt circle		75	90	100	126	135	170	200
# boltholes		4	4	4	4	4	8	8
size bolt holes		14	18	18	22	22	22	26

All dimensions in mm

Type B, Type E

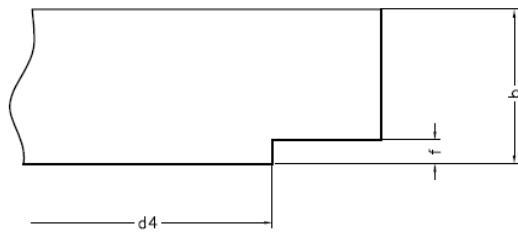

Type C

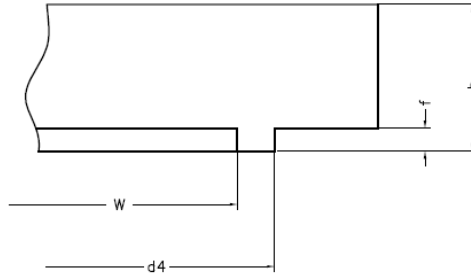

Type D

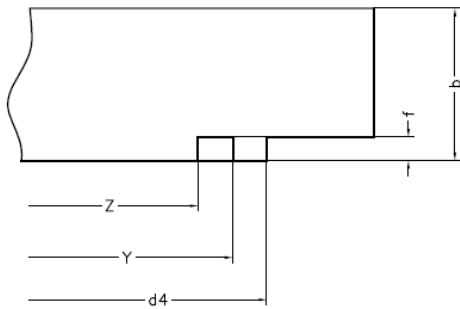

Type F

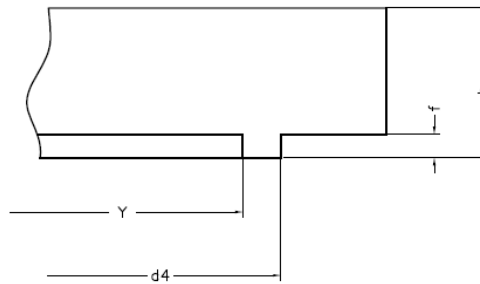

Pressure Rating PN100

Process Connection size		DN15	DN20	DN25	DN40	DN50	DN80	DN100
Outside diameter flange	O	105	130	140	170	195	230	265
Minimum thickness incl facing	b	20	22	24	26	28	34	36
Facing height Type B, D, F	f	2	2	2	3	3	3	3
Facing height Type C, E	f	7	7	7	7	7	7	7
Outside diameter facing Type B, D, F	d4	45	58	68	88	102	138	158
Outside diameter Tongue/Spigot Type C, E	d4	39	50	57	75	87	120	149
Outside diameter groove/recess Type D, F	Y	40	51	58	76	88	121	150
Inside diameter groove Type D	Z	28	35	42	72	72	105	128
Inside diameter Tongue Type C	W	29	36	43	61	73	106	129
diameter bolt circle		75	90	100	125	145	180	210
# boltholes		4	4	4	4	4	8	8
size bolt holes		14	18	18	22	26	26	30

All dimensions in mm

Type B, Type E

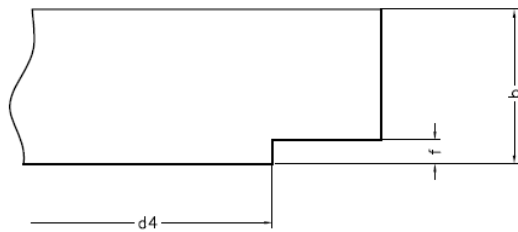

Type C

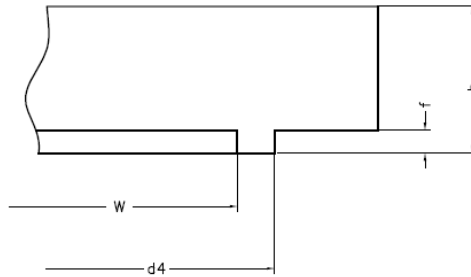

Type D

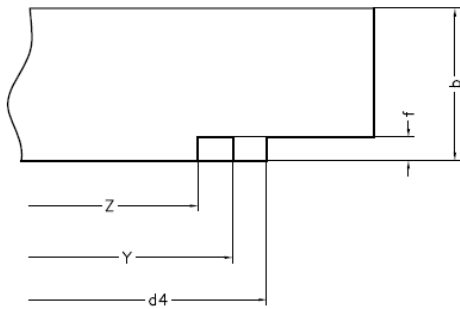

Type F

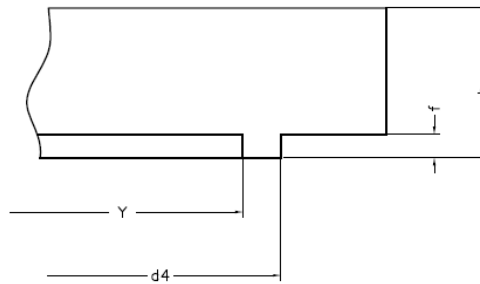

ASTM A182 Gr. F316 (AISI 316)

	cl. 150	cl. 300	cl. 400	cl. 600	cl. 900	cl. 1500	cl. 2500
-29 to 38°C	19,0	49,6	66,2	99,3	148,9	248,2	413,7
50°C	18,4	48,1	64,2	96,2	144,3	240,6	400,9
100°C	16,2	42,2	56,3	84,4	126,6	211,0	351,6
150°C	14,8	38,5	51,3	77,0	115,5	192,5	320,8
200°C	13,7	35,7	47,6	71,3	107,0	178,3	297,2
250°C	12,1	33,4	44,5	66,8	100,1	166,9	278,1
300°C	10,2	31,6	42,2	63,2	94,9	158,1	263,5
325°C	9,3	30,9	41,2	61,8	92,7	154,4	257,4
350°C	8,4	30,3	40,4	60,7	91,0	151,6	252,7
375°C	7,4	29,9	39,8	59,8	89,6	149,4	249,0
400°C	6,5	29,4	39,3	58,9	88,3	147,2	245,3
425°C	5,5	29,1	38,9	58,3	87,4	145,7	242,9
450°C	4,6	28,8	38,5	57,7	86,5	144,2	240,4
475°C	3,7	28,7	38,2	57,3	86,0	143,4	238,9
500°C	2,8	28,2	37,6	56,5	84,7	140,9	235,0
538°C	1,4	25,2	33,4	50,0	75,2	125,5	208,9

Note: maximum allowed pressure in bar per rating per temperature

Note: also valid for dual grade material

ASTM A182 Gr. F51 (Duplex)

	cl. 150	cl. 300	cl. 400	cl. 600	cl. 900	cl. 1500	cl. 2500
-29 to 38°C	20,0	51,7	68,9	103,4	155,1	258,6	430,9
50°C	19,5	51,7	68,9	103,4	155,1	258,6	430,9
100°C	17,7	50,7	67,5	101,3	152,0	253,3	422,2
150°C	15,8	45,9	61,2	91,9	137,8	229,6	382,7
200°C	13,8	42,7	56,9	85,3	128,0	213,3	355,4
250°C	12,1	40,5	53,9	80,9	121,4	202,3	337,2
300°C	10,2	38,9	51,8	77,7	116,6	194,3	323,8
325°C	9,3	38,2	50,9	76,3	114,5	190,8	318,0
350°C	8,4	37,6	50,2	75,3	112,9	188,2	313,7
375°C	7,4	37,4	49,8	74,7	112,1	186,8	311,3
400°C	6,5	36,5	48,9	73,3	109,8	183,1	304,9

Note: maximum allowed pressure in bar per rating per temperature

ASTM B564 Gr. N04400 (Monel 400)

	cl. 150	cl. 300	cl. 400	cl. 600	cl. 900	cl. 1500	cl. 2500
-29 to 38°C	15,9	41,4	55,2	82,7	124,1	206,8	344,7
50°C	15,4	40,2	53,7	80,5	120,7	201,2	335,3
100°C	13,8	35,9	47,9	71,9	107,8	179,7	299,5
150°C	12,9	33,7	45,0	67,5	101,2	168,7	281,1
200°C	11,5	32,7	43,6	65,4	98,1	163,5	272,4
250°C	12,1	32,6	43,5	65,2	97,8	163,0	271,7
300°C	10,2	32,6	43,5	65,2	97,8	163,0	271,7
325°C	9,3	32,6	43,5	65,2	97,8	163,0	271,7
350°C	8,4	32,6	43,4	65,1	97,7	162,8	271,3
375°C	7,4	32,4	43,2	64,8	97,2	161,9	269,9
400°C	6,5	32,1	42,8	64,2	96,2	160,4	267,4
425°C	5,5	31,6	42,2	63,3	94,9	158,2	263,6
450°C	4,6	26,9	35,9	53,8	80,7	134,5	224,2
475°C	3,7	20,8	27,7	41,5	62,3	103,8	173,0

Note: maximum allowed pressure in bar per rating per temperature

ASTM – B462 Gr. N10276 (Hastelloy C-276)

	cl. 150	cl. 300	cl. 400	cl. 600	cl. 900	cl. 1500	cl. 2500
-29 to 38°C	20	51,7	68,9	103,4	155,1	258,6	430,9
50°C	19,5	51,7	68,9	103,4	155,1	258,6	430,9
100°C	17,7	51,5	68,7	103,0	154,6	257,6	429,4
150°C	15,8	50,3	66,8	100,3	150,6	250,8	418,2
200°C	13,8	48,3	64,5	96,7	145,0	241,7	402,8
250°C	12,1	46,3	61,7	92,7	139,0	231,8	386,2
300°C	10,2	42,9	57,0	85,7	128,6	214,4	351,1
325°C	9,3	41,4	55,0	82,6	124,0	206,6	344,3
350°C	8,4	40,3	53,6	80,4	120,7	201,1	335,3
375°C	7,4	38,9	51,6	77,6	116,5	194,1	323,2
400°C	6,5	36,5	48,9	73,3	109,8	183,1	304,9
425°C	5,5	35,2	46,5	70,0	105,1	175,1	291,6
450°C	4,6	33,7	45,1	67,7	101,4	169,0	281,8
475°C	3,7	31,7	42,3	63,4	95,1	158,2	263,9
500°C	2,8	28,2	37,6	56,5	84,7	140,9	235,0
538°C	1,4	25,2	33,4	50,0	75,2	125,5	208,9
550°C		25,0	33,3	49,8	74,8	124,9	208,0
575°C		24,0	31,9	47,9	71,8	119,7	199,5
600°C		21,6	28,6	42,9	64,2	107,0	178,5
625°C		18,3	24,3	36,6	54,9	91,2	152,0
650°C		14,1	18,8	28,1	42,2	70,4	117,3
675°C		11,5	15,4	23,0	34,6	57,6	96,0

Note: maximum allowed pressure in bar per rating per temperature

About Badotherm

We are a European manufacturer of mechanical process instruments with a worldwide distribution network. We have regional Diaphragm Seal assembly facilities in Europe, the Middle East, India, the Far East and the Americas. We design, engineer and manufacture Diaphragm Seals, Pressure Gauges, Temperature Gauges and Thermowells, Instrument Valves and Manifolds. Next to our product offering, we develop tailor-made solutions for challenging conditions in the field of Diaphragm Seal measurements. Headquartered in the Netherlands, we employ over 225 people in seven different countries.



Europe

Badotherm Holland
Kelvinstraat 13
3316 GM Dordrecht
P.O. box 485
The Netherlands
+31 (0)78 654 5800
sales@badotherm.com

Middle East

Badotherm Middle East
RA08WF04
P.O. box 18576
Jebel Ali Dubai
United Arab Emirates
+971 488 356 33
sales@badotherm.ae

South Asia - India

Badotherm India
92B-93B sector 5, HSIDC
IMT Manesar
Haryana, Delhi
India
+91 124 229 10 53
sales@badotherm.co.in

Far East

Badotherm Far East
254 Soi Onnuch 40
Sukhumvit 77
Suanluang 10253
Bangkok 10250, Thailand
+66 2 730 65 00
sales@badotherm.co.th

Americas

Badotherm Americas
6614, Bourgeois Road
Houston, 77066 Texas
United States of America
+1 281 537 78 13
sales@badotherm.us

United Kingdom

Badotherm UK
Merchantsway, Aldridge
Walsall, West Midlands
WS9 8SW United Kingdom
+44 192 274 34 24
sales@badotherm.co.uk

Romania

Badotherm Romania
Metalurgiei 2
730233 Vaslui
Romania
+40 235 340 157
sales@badotherm.ro



MJ Systems, LLC

Authorized Bliss Distributors

TX - Off (281) 842-7600

LA - Off (225) 726-7114

www.mjsusa.com • sales@mjsusa.com